

# FORUM

ISASI

**Air Safety Through Investigation**

JULY-SEPTEMBER 2019

**Journal of the International Society of Air Safety Investigators**

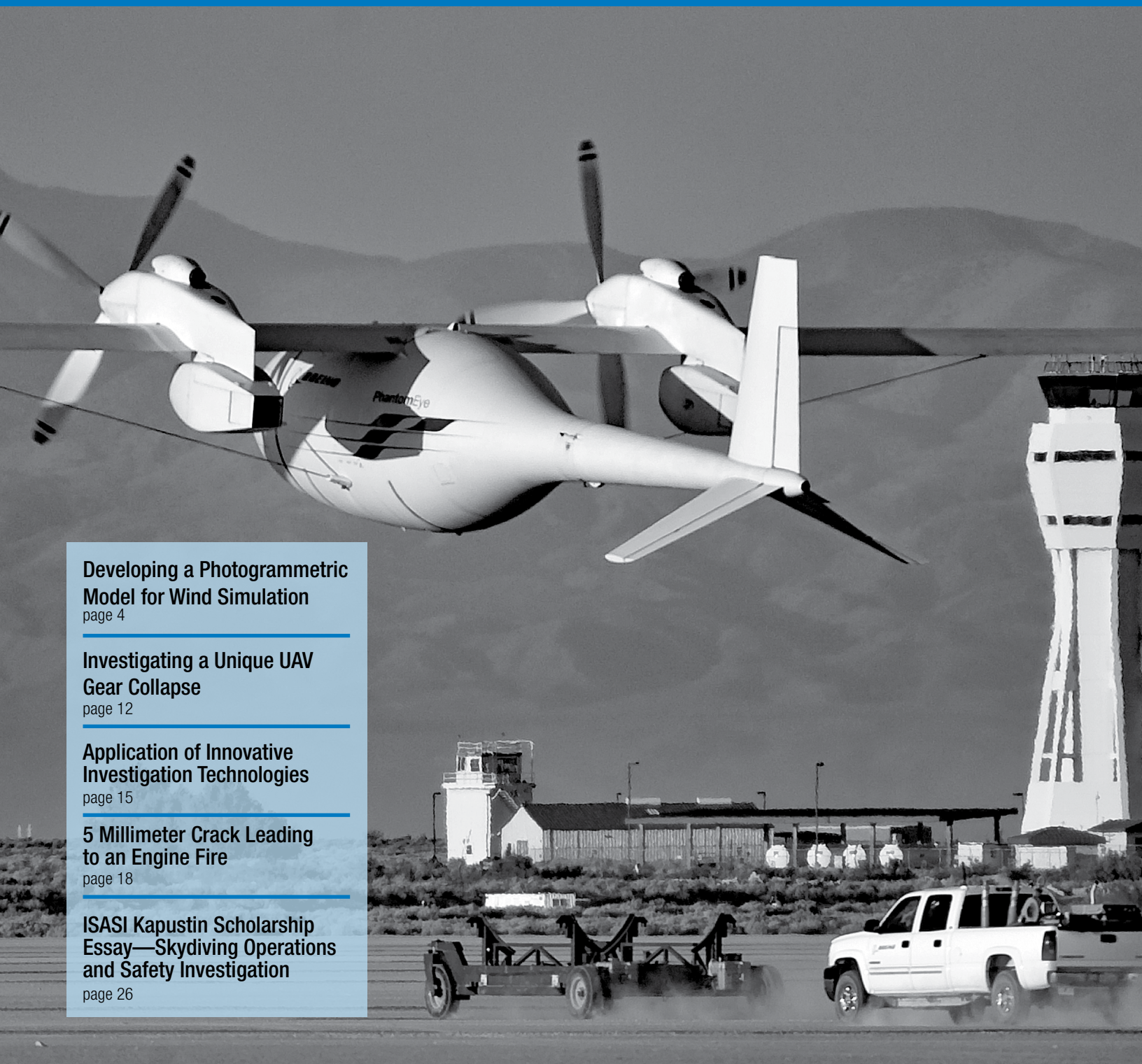

**Developing a Photogrammetric Model for Wind Simulation**

page 4

**Investigating a Unique UAV Gear Collapse**

page 12

**Application of Innovative Investigation Technologies**

page 15

**5 Millimeter Crack Leading to an Engine Fire**

page 18

**ISASI Kapustin Scholarship Essay—Skydiving Operations and Safety Investigation**

page 26

# CONTENTS

# FORUM

Air Safety Through Investigation

Journal of the International Society of Air Safety Investigators

## FEATURES

### 4 Developing a Photogrammetric Model for Wind Simulation

By Michael Bauer, William English, and Michael Richards, U.S. National Transportation Safety Board, and Matthew Grzych, the Boeing Company—*The authors noted that the activities conducted serve as a proof of concept for an innovative investigative technique, demonstrating the breadth of potential use cases for sUAS to support accident investigation.*

### 12 Investigating a Unique UAV Gear Collapse

By James Buse, Senior Technical Lead System Safety, and Jeff Kraus, UAS Flight Test Safety Lead, the Boeing Company—*The authors describe their investigation of a landing incident during the first flight of a high-tech drone in June 2012 and the measures Boeing took to correct the problem.*

### 15 Application of Innovative Investigation Techniques

By Sundeeep Gupta, Accident Investigator, Product Safety, Airbus—*The author describes innovative investigation technology, including satellite imagery, ballistic analysis, radar scanning, and 3-D laser scanning used to locate engine components scattered from an uncontained engine failure on an A380 cruising at 37,000 feet over Greenland.*

### 18 5 Millimeter Crack Leading to an Engine Fire

By David Lim, Principal Investigator, Transport Safety Investigation Bureau, Singapore—*The author presents lessons learned from investigation of an engine fire on a B-777-300ER that departed from Singapore to Milan in June 2016.*

### 26 ISASI Kapustin Scholarship Essay—How an Extreme Sport Highlights Broader Issues for Air Safety Investigators: Sky Diving Operations and Safety Investigations

By Avery Katz, Embry-Riddle Aeronautic University, 2018 ISASI Rudolf Kapustin Memorial Scholarship Recipient—*The author discusses how an extreme sport presents unusual and broader issues that accident investigators must address.*

## DEPARTMENTS

- 2 Contents
- 3 President's View
- 28 News Roundup
- 30 ISASI Information
- 32 ANZSASI Holds Annual Regional Seminar

## ABOUT THE COVER

A Boeing Phantom Eye UAV liquid-hydrogen-fueled prototype lifts off from a lakebed at Edwards Air Force Base in California, USA, in June 2012 for its first flight. The high-altitude, long-endurance aircraft is designed to remain airborne for up to four days while reaching altitudes of up to 65,000 feet. Upon landing, the nosewheel separated as it contacted the runway, leading to a unique investigation that required unusual procedures (see page 12).

Volume 52, Number 3

Publisher Frank Del Gandio

Editorial Advisor Richard B. Stone

Editor J. Gary DiNunno

Design Editor Jessica Ferry

Associate Editor Susan Fager

*ISASI Forum* (ISSN 1088-8128) is published quarterly by the International Society of Air Safety Investigators. Opinions expressed by authors do not necessarily represent official ISASI position or policy.

*Editorial Offices:* Park Center, 107 East Holly Avenue, Suite 11, Sterling, VA 20164-5405. Telephone 703-430-9668. Fax 703-430-4970. E-mail address, [isasi@erols.com](mailto:isasi@erols.com); for editor, [jgdassociates@starpower.net](mailto:jgdassociates@starpower.net). Internet website: [www.isasi.org](http://www.isasi.org). *ISASI Forum* is not responsible for unsolicited manuscripts, photographs, or other materials. Unsolicited materials will be returned only if submitted with a self-addressed, stamped envelope. *ISASI Forum* reserves the right to reject, delete, summarize, or edit for space considerations any submitted article. To facilitate editorial production processes, American English spelling of words is used.

*Copyright* © 2019—International Society of Air Safety Investigators, all rights reserved. Publication in any form is prohibited without permission. *ISASI Forum* registered U.S. Patent and T.M. Office. Opinions expressed by authors do not necessarily represent official ISASI position or policy. Permission to reprint is available upon application to the editorial offices.

*Publisher's Editorial Profile:* *ISASI Forum* is printed in the United States and published for professional air safety investigators who are members of the International Society of Air Safety Investigators. Editorial content emphasizes accident investigation findings, investigative techniques and experiences, regulatory issues, industry accident prevention developments, and ISASI and member involvement and information.

*Subscriptions:* A subscription to members is provided as a portion of dues. Rate for nonmembers (domestic and Canada) is US\$28; Rate for nonmember international is US\$30. Rate for all libraries and schools is US\$24. For subscription information, call 703-430-9668. Additional or replacement *ISASI Forum* issues: Domestic and Canada US\$4; international member US\$4; domestic and Canada nonmember US\$6; international nonmember US\$8.



INCORPORATED AUGUST 31, 1964

# PRESIDENT'S VIEW

## CONTINUING TO IMPROVE FLIGHT SAFETY IN THE YEARS TO COME

“ WE'RE PROUD OF OUR HISTORY, OUR PRESENT EFFORTS, AND OUR WILLINGNESS TO PROJECT OUR EXPERIENCE AND EXPERTISE INTO AIR SAFETY'S FUTURE. ”

**A**s I write my opening statement for ISASI 2019 in early September, I think about many of the programs our Society has to offer to ISASI members and to air safety throughout the world and the efforts ISASI makes in preparation for the future. Yes, our premier event is the annual seminar that gives air safety professionals an opportunity to share their expertise through tutorials, technical presentations, and informal networking discussions. But there is a great deal more occurring throughout the year.

We recently participated in the 54th Reachout program that provided air safety instruction not only to ISASI members in Pakistan, but also to government officials and personnel, members of the military, and other safety professionals. There have been 3,272 participants in Reachouts since this program's inception in 2001.

We encourage aviation students to learn about air safety careers through our student outreach programs that include student ISASI chapters at accredited aviation colleges and continue

to offer aviation students a scholarship that allows them to attend our seminar and other aviation safety training programs. We're a sponsor of the Harry Robinson Fellowship program that provides a stipend to an advanced college degree student who's conducting research in an air safety subject.

We're an active participant as an official observer organization in International Civil Aviation Authority (ICAO) proceedings and rulemaking. ICAO is the global aviation authority within the United Nations. For the last five years, our Society representatives have been a part of the ICAO Accident Investigation Panel that meets annually in Montreal, Quebec, Canada. The work of the group leads to updates and additions to ICAO standards and procedures for accident investigations throughout the world.

Our recent inauguration of a digital *ISASI Forum* is an attempt to better reach members and subscribers who are often away from their homes or worksites and may want to read our magazine in a more timely manner and also as a means

of interesting air safety professionals who are just starting their careers. This magazine format is sent electronically to members and subscribers who prefer to receive their information through computers or other electronic devices, rather than a printed and mailed copy. Receiving either format has two requirements: You must be an ISASI member in good standing and your mailing or e-mail address must be accurate. If you need to "fix" either of these requirements or wish to switch your magazine delivery option, please contact ISASI's editorial offices (see page 2 of this issue).

During the spring ISASI International Council meeting, a committee was established to review the Society's official *Positions on Air Safety Issues*, which is posted on our website under the Guidelines tab. This periodic review is designed to ensure that our policies and positions are current. The committee determined that no changes are required at this time.

A pamphlet about the Society's history and accomplishments will be

distributed to ISASI 2019 participants and then will be posted on our website.

It's safe to say that ISASI, through our members, has some presence everywhere in the world where air safety is an issue. We're proud of our history, our present efforts, and our willingness to project our experience and expertise into air safety's future. That future may take us farther than this world. The future of air safety investigation depends upon those of us who have experience to pass the torch to next-generation air safety professionals who can assimilate what we learned and practiced while adding new expertise and experience to continue improving air and space flight safety in the years to come. ♦



Frank Del Gandio  
ISASI President

# DEVELOPING A PHOTOGRAMMETRIC MODEL

By Michael Bauer, William English, and Michael Richards, U.S. National Transportation Safety Board, and



Michael Bauer



William English



Michael Richards



Matthew Grzych

**D**uring the on-scene investigation of an accident in which a transport-category airplane overran a runway, NTSB investigators found that the inboard linkage components of the right elevator's geared tab were locked in an overcentered position and bent outboard, effectively jamming the right elevator. This condition prevented the right elevator from responding to cockpit control inputs and precluded airplane pitch response and rotation during takeoff. Initial stages of the investigation found no evidence that the condition resulted from improper maintenance or collision with a vehicle or other object. Before the accident flight, the airplane had been parked during a period of abnormally high, gusting wind conditions, and flight data recorder information (which recorded when the right elevator was last in a different position) showed that the right elevator became jammed sometime during the two days that the airplane was parked on the ramp before the accident.

## Statement of the problem

A lack of local wind data availability and the likely effects of a large hangar on the wind characteristics where the airplane had been parked challenged the investigation's ability to determine how the right elevator's geared tab linkage became locked overcenter. Although a CFD wind simulation could provide insight into the likely characteristics of the wind flow at the airplane's parked location, an accurate 3-D model of the large hangar upwind of the parking ramp was needed but could not be feasibly produced using conventional techniques.

The wind flow information was critical for supporting the investigation's development of a series of static and dynamic elevator load tests to determine what conditions, consistent with the known circumstances of the accident, could result in the jammed elevator condition. Although the NTSB's UAS Team had been using a fleet of sUAS as a new investigative technique for capturing imagery at various accident sites for approximately a year, supporting the development of a 3-D model for use in a CFD wind simulation was a new application of this technology.

## Incomplete meteorological data for airport

The accident occurred on March 8, 2017, at Willow Run Airport (YIP) in Ypsilanti, Michigan, USA, and an NTSB meteorologist was assigned to the investigation. Official wind observations at YIP were taken from an automated surface observing system (ASOS) anemometer located near midfield, 1,490 meters (4,888 feet) east of the location where the airplane was parked (see Figure 1). This anemometer was at a height of 10 meters (33 feet) above ground level (AGL) and was sited to observe unobstructed wind flow from any direction. Although the ASOS is an authoritative source of wind data, due to a regional power outage the ASOS anemometer became inoperative about four hours before, and remained inoperative until well after the time of the accident. Prior to the power loss, the ASOS anemometer's maximum observed wind gust (five-second average) was 55 knots from the west-southwest. ASOS anemometer data did not distinguish between the horizontal and vertical components of the wind.

Although two additional anemometers were present at YIP, neither provided investigators with authoritative wind data for the accident day. A stand-alone weather sensor (SAWS) that included an anemometer was on the field northeast of the airplane's parked location; however, the SAWS became inoperative about the same time as the ASOS anemometer, and archived data from before the power outage was not available.

Although another anemometer that was owned by the local airport authority and located southeast of the airplane's parked location continued to provide data even after the ASOS and SAWS lost power, a comparison of this anemometer's data with the ASOS data (for times when the ASOS was operational) revealed that the airport authority's anemometer data showed a significant bias. Further, the airport authority's anemometer provided data only every five minutes with some unknown sampling criteria, was at a height of about 2.7 to 3.1 meters (nine to 10 feet), may not have been well sited, and had unknown maintenance standards. The issues associated with these two anemometers, combined with the power loss to the ASOS, left investigators without credible wind

# FOR WIND SIMULATION

Matthew Grzych, the Boeing Company

*(Adapted with permission from the authors' technical paper titled Use of sUAS in Developing a Photogrammetric Model for Wind Simulation presented during ISASI 2018, Oct. 30–Nov. 1, 2018, in Dubai, the United Arab Emirates. The authors noted that this white paper is not intended to be a scientific study. The activities conducted served as a proof of concept for an innovative investigative technique, demonstrating the breadth of potential use cases for small unmanned aircraft systems to support accident investigation. The theme for ISASI 2018 was "The Future of Aircraft Accident Investigation." The full presentation can be found on the ISASI website at [www.isasi.org](http://www.isasi.org) in the Library tab under Technical Presentations.—Editor)*

information for YIP for about a four-hour period before the accident.

## Potential effect of large hangar on wind flow

Although the ASOS anemometer provided reliable, authoritative airport wind information while it was operative, the airplane had been parked facing north immediately downwind, on the east side, from a large hangar. The hangar was more than 0.4 kilometers (0.25 miles) long and equipped with duct work, chimneys, ladders, and detailed architecture; it was also surrounded by bushes, trees, and varied terrain near a retention pond. All of these characteristics would likely disrupt wind flow. Due to the size and characteristics of the hangar obstruction and surrounding terrain, as well as the distance of the airplane's parked location from the ASOS, investigators suspected that any available airport wind data from the ASOS likely did not represent the localized airflow at the airplane's parked location (see Figure 2, page 6).

## Need for CFD wind simulation

Given the lack of complete wind data for YIP in the hours before the accident and the size and characteristics of the large hangar upwind of the airplane's parked location, determining the localized airflow that likely affected the airplane required an additional investigative technique. The Boeing Company, which was a party to the NTSB's investigation, was capable of performing a CFD wind simulation of conditions downwind of hangar using available wind data, pavement temperature information from an airport authority sensor, and additional meteorological data. However, to maximize the fidelity of the wind simulation, a photogrammetric 3-D model of the hangar that could be imported into the CFD simulation was needed.

## Limitations of traditional investigative techniques for developing 3-D hangar model

Due to the 1940s vintage of the hangar,

the likelihood of a digital 3-D model of it already existing—especially with the fidelity necessary for the CFD work—was remote. Creating a 3-D



**Figure 1.** Airport map showing the relative locations of the hangar (dimensions highlighted in blue), the accident airplane's parking spot, and various weather observing equipment.

model of the complex building and terrain environment would conventionally require using blueprints, photographs, terrain data, and CAD software to manually create the model. This would involve considerable resources in time and manpower. For example, it would be difficult to manually create the basic hangar structure alone, and adding the intricate accessories (duct work, chimneys, ladders, detailed architecture, bushes, trees, terrain near the retention pond, etc.) could take weeks of additional labor. Further, such a monumental effort still might not provide the level of accuracy needed. For effective use in the CFD simulation, which has 0.5 meters (1.6 feet) resolution, the input model must have at least that level of accuracy to model small-scale turbulent wind patterns caused by the obstructions.

## Basis for considering use of sUAS as new investigative technique

The NTSB meteorologist and NTSB sys-

tems investigator assigned to the investigation approached the NTSB UAS Team program lead to determine the feasibility of using the NTSB's sUAS fleet to capture the necessary imagery and use it to create a photogrammetric 3-D model of the hangar. At the time, the NTSB UAS Team had been using drones for about one year to capture imagery at various accident sites and had been using the commercially available photogrammetry software to develop 3-D models of the sites from the drone-captured imagery. Past models developed using the software were well within the accuracy requirements specified to support the CFD simulation for this investigation.

## Evaluating feasibility of using sUAS imagery to develop 3-D model

*Determining photogrammetry product compatibility*

Before accepting the mission, the NTSB UAS Team needed to determine if the output products from a photogrammetry



*Figure 2. View looking west toward the hangar, taken from the approximate parked location of the accident airplane. (Airplane in picture is much closer to the hangar.)*

program could be imported into the CFD program used by Boeing. Photogrammetry, or more specifically stereo photogrammetry, determines the 3-D coordinates of points on an object by employing measurements made from multiple photographic images taken from different positions. Common points are identified on each image, and the intersection of the lines from the camera locations to the point on the object determines the 3-D location. This 3-D point cloud model of the subject is then used to build a textured mesh representation of the object. Although not as precise as the point cloud, the mesh object could potentially be used as a solid object in various software environments, such as the CFD wind simulation, and provide more detail than the simple geometric shapes normally used.

To capture imagery and create a mesh representation of an object that could be tested with the CFD software, the NTSB UAS Team conducted proving flights at the test facility near the NTSB Training Center in Ashburn, Virginia, USA. (This “test track” was the former George Washington University solar vehicle field, which the NTSB can use under agreement for UAS training and research and development.)

During one proving flight, the UAS Team thoroughly captured images of an equipment shed at the field using flight patterns recommended by Pix4D, the

developer of the commercially available photogrammetry software. The drone was flown in a double grid pattern with the camera pointed in combinations of nadir (straight down) and slightly off vertical, as well as oblique patterns around the perimeter of the shed. The flight resulted in about 70 photographs, which were processed into a point cloud, and a 3-D mesh in .obj format was exported for use in the CFD simulation model. (.obj file is a geometry definition file. It is an open format and was developed by Wavefront Technologies for its animation software. The format is also used by various other 3-D graphics applications.)

The Boeing CFD specialist was able to import the test item into the CFD simulation model and, based on the results, was

optimistic that such 3-D mesh objects could contribute greatly to the accuracy of the model environment.

#### *Assessing size of structure and area to be modeled*

Once the initial feasibility of providing a CFD-compatible model was demonstrated, the Boeing CFD specialist provided the UAS Team with specifications for the area to be modeled to support the wind simulation study. Conceptually, modeling the hangar was feasible for the UAS Team; however, at more than 0.4 kilometers (0.25 miles) long, the structure was much larger than anything the team had modeled before. In addition, the CFD specialist requested mapping of a large area of the surrounding terrain.

A map of the area of interest to be modeled was provided, with the highest priority being the southern portion of the hangar, parking ramp, and a nearby retention pond, with some lower priority “reach” areas across a vehicle lot. Although the CFD specialist initially requested a model of about only half of the hangar, the historical aspects of the hangar, which was scheduled for demolition, were considered. Known as Hangar 1, it was one of the last remaining buildings of the former Willow Run Bomber Plant complex that produced the Consolidated B-24 Liberator bomber from World War II. The UAS Team determined that acquiring the imagery to model the entire hangar would not require substantially more flight time. Thus, the UAS Team determined that mapping the entire hangar, thereby preserving it in a digital format, would be worth the additional effort. Further, the additional imagery would be available to the investigation, if required for the analysis.

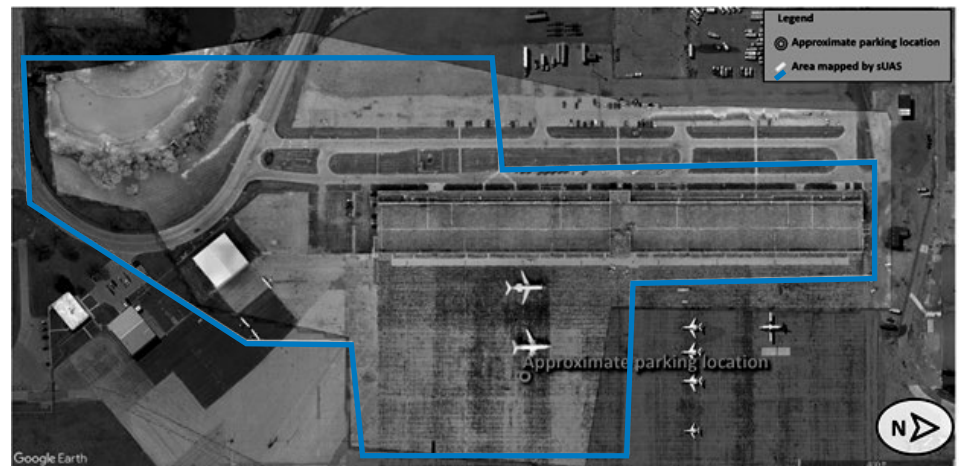

*Figure 3. Orthomosaic image showing planned sUAS mapping area in blue.*

## Conducting sUAS flight missions

### *Preflight planning to capture optimal imagery*

Considering the scope of the planned project, the NTSB UAS Team worked with specialists from Pix4D to ensure that the planned missions would be flown a manner that most effectively and efficiently gathered the necessary data. The UAS Team developed a flight plan that incorporated double grids over the top of the entire hangar, followed by two orbits at different altitudes and camera angles to ensure full coverage of the sides of the building.

The altitudes of the grids and oblique flight paths were planned to give the best balance of coverage (including overlap) and accuracy. Grids flown at a higher altitude provided better overlap and matching between the photographs for the photogrammetry processing, especially considering the somewhat homogenous nature of the hangar roof. In a general sense, however, some photographic detail is lost with higher altitudes because the ground sample distance (GSD) increases as the camera moves further from the ground. (In a digital photograph, GSD is the ground distance represented by the distance between the centers of two pixels.)

The UAS Team flew the hangar grids at 46 meters (150 feet) AGL and positioned the oblique flights to fill the frame to the extent possible with the target object (hangar) and minimize the background, such as sky and ramp. The team positioned additional grids over the terrain and a small hangar to the south and east of the main hangar (see Figure 3). Pre-planning the flight missions resulted in an estimate of more than one hour of expected flying and more than 1,000 images.

### *Airspace access considerations*

At the time of the flights, gaining approval for conducting sUAS operations in controlled airspace (like YIP) involved either a time-consuming manual authorization process under Title 14 Code of Federal Regulations (CFR) Part 107 or the use of a government agency public safety emergency Certificate of Waiver or Authorization (eCOA). Initially, the UAS Team coordinated with the Michigan State Police (MSP) to ascertain if the MSP's jurisdictional Certificate of Waiver or Authorization (COA), which covered the airport, could be used. (MSP

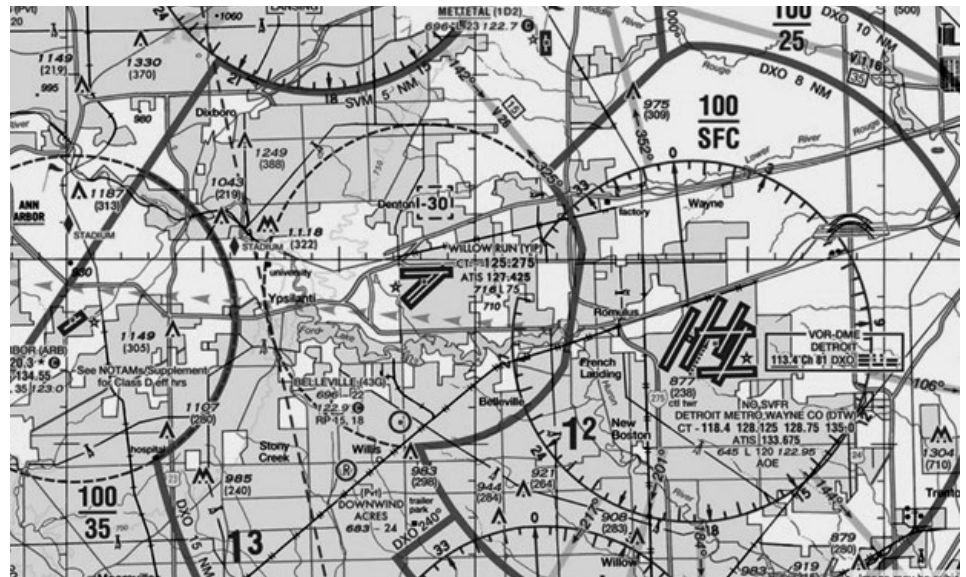

Figure 4. Sectional showing YIP and the surrounding airspace.

officers were among the first responders to the accident and used their sUAS to photograph the wreckage, ground scars, and runway.) Meanwhile, the NTSB UAS program lead began coordinating with the U.S. Federal Aviation Administration (FAA) for airspace access.

During this process, the UAS Team learned that the MSP was unavailable at the proposed times for the flight; thus, an eCOA was needed. (Note: Currently, the FAA provides an automated airspace access system, low altitude authorization and notification capability, as well as the special government interest protocol, both of which allow for much more expeditious sUAS access to controlled airspace.)

The NTSB UAS Team had previously used eCOAs for conducting sUAS operations over active accident scenes, but none of those site areas had been as large as the hangar mapping project, which required lengthy flights in close proximity to manned aircraft operations. YIP was a busy freight hub in Class D airspace, underlying a shelf of the Detroit Class B airspace (see Figure 4).

Further, the hangar was located in between the ends of the two main runways and contained the U.S. Customs facility, a fixed-base operator (FBO), and other businesses. An active general aviation flight school was immediately south of, and sharing ramp space with, the hangar. The sUAS flights would need to operate concurrently with manned aircraft flights as the airport continued normal operations throughout the mission.

Fortunately, with excellent FAA coop-

eration, the eCOA was developed and issued with ample lead time before the mission. The NTSB UAS program lead provided a detailed map of the operating area and proposed flight plans, and FAA headquarters personnel coordinated with YIP air traffic control (ATC) personnel to develop procedures for the flights. These combined efforts determined that operations under the eCOA were subject to the following requirements:

- A flight team consisting of a remote pilot-in-command (RPIC) and visual observer (VO),
- Issuance of a notice to airmen (NOTAM) prior to the day's sUAS flights (as coordinated between the FAA and NTSB UAS program lead),
- Restrictions that sUAS operations must remain clear of all runways and moving aircraft, and
- RPIC communication with the ATC tower personnel via two-way radio prior to each sortie.

The eCOA covered the planned mission date and included a contingency day to account for weather or data quality/operational issues, if needed.

## Mission considerations: weather, airport activity, and other challenges

### *Weather*

The mission day dawned with high, thin overcast and light surface winds, which were ideal for photogrammetric flights. However, the forecast called for storms to move through by the middle of the day, leaving a relatively narrow time window

to accomplish the flights. In consideration of the approaching weather, the UAS Team prioritized the sorties to ensure that the most critical portions of the hangar were captured first in the event that subsequent sorties would have to be canceled.

#### *Preflight coordination*

The UAS Team, consisting of an RPIC and VO, arrived early to the hangar and contacted the ATC personnel, who acknowledged the NOTAM information and added an advisory on the automatic terminal information service (ATIS) to advise local pilots of the UAS activity near the hangar below 61 meters (200 feet) AGL. Airport management was supportive, providing access to the airside ramp east of the hangar and the area around the flight school hangar.

#### *Mission sorties*

The UAS Team staged the drone for the first sortie at the northwest corner of the hangar. Per the established plan, the first overflight grid was flown at 46 meters (150 feet) AGL. Breaking up the grid into four separate flights (one for each quadrant) aided in maintaining required visual line of sight (VLOS) with the drone and provided the opportunity for the team to quality check the image files while the drone was landed between flights.

To maximize efficiency, the RPIC and VO worked a rotating plan of action: While the RPIC (UAS program lead) input the flight plan grids or orbits on the sUAS control tablet, the VO used a differential global positioning system (DGPS) to survey ground control points (GCPs) around the hangar. After each sortie, while the RPIC swapped out drone batteries and prepared for the next mission, the VO downloaded the images from drone's data card, reviewed them, and created backup copies of the images.

As the missions proceeded, the team decided to fly an extra orbit around a small tower to ensure the best detail coverage of the complex structure and angles, which might affect the wind simulation. While orbiting the small tower, which housed radio equipment for the U.S. Customs and FBO operations, the RPIC experienced a brief global positioning system (GPS) and compass error with the sUAS. To address the issue, the RPIC immediately backed the drone away from the tower, which cleared the error,

and then proceeded with the mission. This was the only (and very brief) technical issue of the day, which presumably occurred when a radio equipment user transmitted just as the drone was close to the tower.

#### *Airport ramp and traffic activity*

Normal airport operations continued throughout the morning, which included multiple cargo and business jet flights and a nearly constant flow of training flights. During the sUAS sorties, airport ramp activity east of the hangar and near the flight school hangar included airplanes entering the ramp for parking and passengers exiting and entering the buildings. To avoid overflight of vehicles and persons, the RPIC performed occasional brief stand-downs by hovering to a safe area or landing until the activity cleared.

During one sortie that launched from the southwest corner of the hangar toward a planned grid to cover the retention pond abeam the approach end of Runway 5L, a pilot of a single-engine Cessna executed a practice engine-out landing and turned directly toward the runway numbers, cutting the corner off the typical traffic pattern. The Cessna's tighter pattern could have brought the airplane concerningly close to the sUAS flight operations area; however, both the RPIC and VO saw the Cessna turning,

communicated with each other, and the RPIC responded by maneuvering the drone away from the grid. Although the Cessna and the drone never entered hazardous proximity to each other, the traffic scenario highlighted the value of close coordination and communication between the RPIC and VO.

UAS Team members later asked ATC personnel if they could see the drone when it was flying. The tower controller stated that they had been looking for it on each sortie but never saw it and also noted that no pilots reported seeing it. The Cessna pilot also stated that he did not see the drone. This information regarding the difficulty (or inability) of ATC personnel and pilots of manned aircraft to see drones served as a good reminder to the RPIC and VO regarding the importance of maintaining required VLOS with the drone and communication with each other, ATC personnel, and, if needed, pilots of manned aircraft when operating in an active airport environment (see Figure 5).

By the time that the last planned sortie was completed, the storms were moving very close to the airport. The desired areas were covered, so after one last quality check the team packed up and headed inside the FBO just in time to avoid the rain.

#### **Equipment used**

*sUAS, cameras, and DGPS*



*Figure 5. Image captured by the drone during the mission. (Note business jet on approach to Runway 5.)*



All equipment used for the effort was commercially available, off the shelf. The team brought two drones: the primary drone used for the mission and one to have available as a backup. The primary aircraft was a DJI Phantom 4 Pro (see Figure 6) equipped with an FC6310 camera using the Sony Exmor one-inch (2.5-centimeter) complementary metal-oxide semiconductor (CMOS) sensor, which provided still photo resolution of 20 megapixels in .jpg or .raw format. The camera was equipped with a mechanical shutter, which was ideal for use in capturing images via drone to support a photogrammetry application. (Mechanical shutters avoid introducing image errors and distortions that can result from the use of an electronic rolling shutter from a moving drone.)

The backup aircraft was a DJI Inspire 1 equipped with the X3/FC350 camera using the Sony Exmor 1/2.3-inch CMOS sensor, which provided a resolution of 12 megapixels. A Trimble Geo 7X DGPS was used to record the GCPs, which were corrected using the continuously operating reference station (CORS), which was coincidentally located less than 0.8 kilometers (0.5 miles) away, in front of the airport fire station.

#### *Software and processing*

To build the 3-D model, the data was processed using the Pix4D Mapper software with a laptop PC compatible with the suggested specifications from Pix4D. Creating a detailed photogrammetric 3-D model of an object the size of the hangar and surrounding terrain at the required resolution required about 1,000 images.

The process of developing the 3-D model through Pix4D began with importing the photographs and validating the image information. During the first step, the software looked for common key points throughout the photographs and marked thousands of overlapping points. Although photographs taken using the drone have geographical information embedded in the metadata, the accuracy is limited to that of an uncorrected GPS—typically within five to 10 meters laterally with height information that can be very inaccurate. The use of GCPs substantially increased accuracy. Past experience of the UAS Team with the Geo 7X showed that, under good conditions with nearby CORS, positional accuracy (relative to Earth's datum) could be as good as four to 10

centimeters (1.6 to 3.9 inches). (The data sheet for the Trimble Geo 7 series units describes the unit's accuracy and reliability and the factors that may introduce anomalies.) Thus, during the first step in the processing, NTSB UAS Team members manually fine-tuned the geographic location information by viewing the images containing the GCPs taken with the DGPS and marking the pixel representing the center of each GCP.

Following the marking of GCPs, the 3-D point cloud, consisting of millions of data points, was constructed. Relative accuracy (in other words, measurements within the point cloud) was measured to approximately 2.5 centimeters (1 inch). (This accuracy is a function of the camera distance and focal length, amount of image overlap, and other factors.) A triangulated 3-D mesh was then built from the point cloud. The mesh processing, which interpolates between points, required some iterative interaction to remove artifacts in the mesh. Typical artifacts in the mesh were evident; for example, the color and texture of the hangar roof were visually similar to the color and texture of the paved ramp areas nearby, which required some manual cleanup of the cloud to build the best 3-D mesh model.

Two separate final mesh files (one of the main hangar building structure and the other of the surrounding terrain, trees, brush, vehicles, and other nearby structures) were exported as a 3-D model in .obj file format and provided to the CFD wind simulation specialist at Boeing.

#### **Digital preservation of historically significant hangar**

Initially, the Boeing CFD specialist asked for imagery of only the southern half of the hangar. However, as the NTSB UAS Team members prepared for the mission, they learned the historical significance of the building. Known as Hangar 1, it was one of the last standing buildings of the Willow Run Bomber Plant complex that produced the Consolidated B-24 Liberator bomber during World War II, and it housed part of the Yankee Air Museum collection. The Willow Run factory complex was the first plant to build bombers on an assembly line, and it was the home of the original "Rosie the Riveters," who were part of the unprecedented expansion of women in the workforce, building part of the American "Arsenal



**Figure 6. The RPIC flying a Phantom 4 Pro drone during a mission sortie.**

of Democracy.”

Looking at the historic photos, it was clear to the team that the exterior of the building was essentially the same as it was in 1944. Hangar 1 was used during World War II as a maintenance depot, providing storage for completed B-24s and modified aircraft (such as radar-equipped “Pathfinders”) until ready for military deployment.

According to the YIP airport master plan, Hangar 1 was scheduled to close and eventually be demolished on Nov. 30, 2018. The only historic portion of the Willow Run Bomber Plant complex to remain (although not in original configuration) was the adjacent portion that served as the end of the assembly line, where aircraft were fueled. (At the time of this report, that building was under renovation to house the museum.) When the NTSB UAS Team learned that this piece of history was endangered, the initial plan to model only about half of the hangar changed: Half wasn't good enough, so we decided to model the whole thing! As a result, this historically significant building was preserved in a digital format through the imagery collected and photogrammetry output produced by the team. Further, obtaining the additional imagery to model the entire hangar did not require substantially more flight time, and the complete model was available for use in investigative analysis.

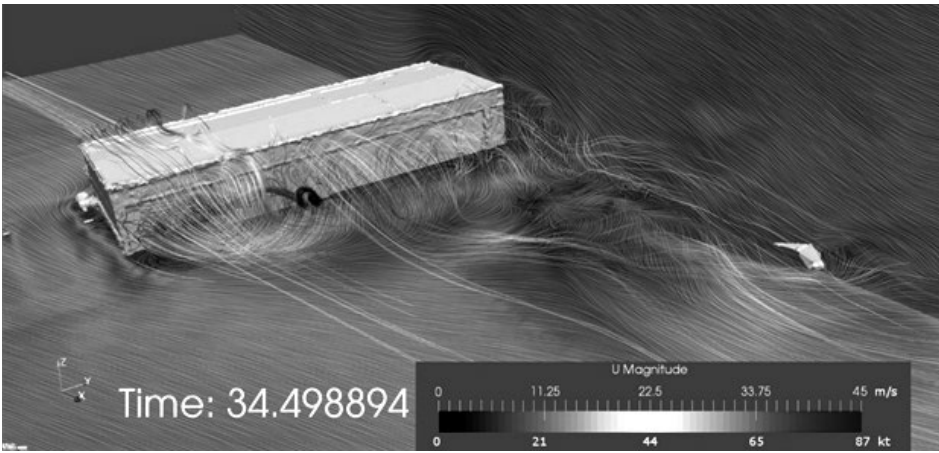

Figure 7. The 3-D visualization of wind simulation results for a discrete time showing turbulence generated downwind of the hangar. Note: The accident airplane's elevators can be seen on lower right side of image.

### CFD wind simulation

#### Further processing to optimize 3-D hangar model

The Boeing CFD specialist found that before the 3-D model mesh files provided by the NTSB UAS Team could be used effectively in OpenFoam (a widely used open-source CFD modeling software), more processing was needed. The specialist combined the mesh files and used the open-source software Blender to manually make the combined mesh “watertight” with essentially no holes. The watertight combined mesh file was further processed using an OpenFoam utility to apply settings that allowed for model stability. The final mesh used for the CFD model wind simulation was a blend of the combined drone mesh data inserted into a 500 x 500 meter flat plane. (A flat, smooth plane was necessary along the model boundaries for model stability.) Finally, an MD-83 model was positioned

in the mesh to represent the parked location of the accident airplane.

#### Results of CFD model analysis study

The Boeing CFD specialist used the final 3-D mesh and the weather information provided by the NTSB meteorologist assigned to the investigation to perform the CFD model analysis. The weather information included variable wind magnitudes, directions, and gusts; pavement temperature; and additional meteorological data.

The wind simulation revealed that, at the accident airplane's parked location, the elevators could have been subjected to hangar-generated turbulent flow that included a small-scale 30+ meters-per-second (58+ knots) gust moving over the airplane. According to the simulation, another possibility included small-scale 15/+15 meters-per-second (-29/+29 knots) vertical vector couplets that moved horizontally toward the air-

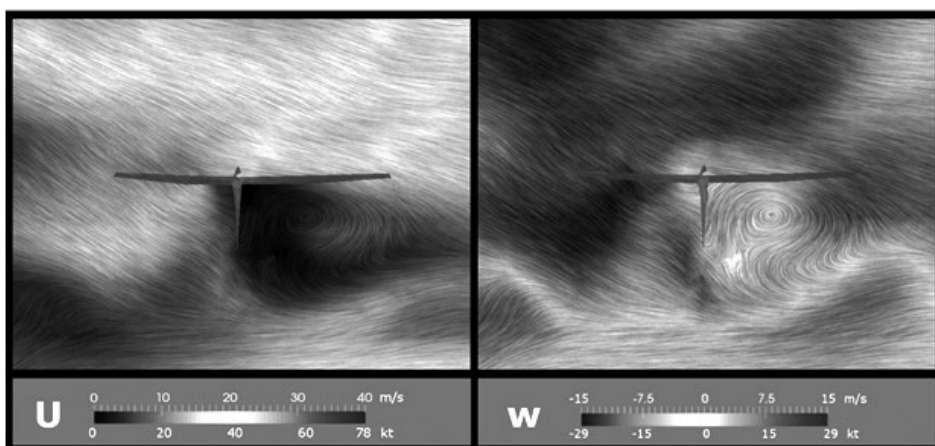

Figure 8. Vertical cross-section visualization of wind simulation results for a discrete time showing horizontal (“U”) and vertical (“W”) wind magnitudes in area of the accident airplane's elevators.

plane with the turbulent gusts and waves that were being generated downstream of the hangar. Figure 7 and Figure 8 show visualizations of select wind simulation results.

#### Full-scale elevator load testing

As described previously, the inboard linkage components of the right elevator's geared tab were locked in an overcentered position and bent outboard, effectively jamming the right elevator and preventing airplane pitch response and rotation during takeoff. When the airplane is parked on the ground, the elevators are free to move independently within the confines of the upper and lower mechanical stops, which inhibit elevator movement in each direction. Although the elevator is designed to distribute increased loading via a torsion bar and stop arm assembly when the elevator is in contact with a stop, excessive loading can result in excessive torsion bar deflection, increasing the likelihood that the geared tab linkage could travel to an overcentered position (see Figure 9).

The CFD results assisted the NTSB systems investigator in designing a more representative test plan for the airplane's elevator system, more specifically the interaction with the elevator stops, which included a series of static and dynamic elevator load tests to determine what conditions, consistent with the CFD results and the known circumstances of the accident, could enable the geared tab linkage to move to an overcentered position and jam the elevator.

In preparing the test plan, investigators used the hinge moment formula specified in 14 CFR 25.415 to calculate the hinge moments needed to simulate static elevator loads from ground gusts of 25, 55, 60, 65, 70, and 75 knots (the maximum recorded wind gust at YIP was 55 knots). The CFD model results indicated the potential for turbulent gust flow around the airplane's elevator to induce both lifting and downward loads. Thus, for each dynamic test, the load was applied to the elevator, then the elevator was raised to either a neutral or full-trailing edge up (TEU) position (using a forklift and lifting straps) before it was released (using a quick-release mechanism). Releasing the lifted elevator from either the neutral or full TEU position allowed it to travel downward and dynamically contact the trailing edge down stop.

None of the static test cases resulted in an overcentered condition of the geared tab linkage. Dynamic tests for simulated gust loads of 25 and 55 knots with the elevator starting in either a neutral or full TEU position did not result in the geared tab linkage becoming overcentered. For the 60-knot simulated gust load, the linkage became overcentered for only the full TEU initial elevator position test. For the 65-, 70-, and 75-knot simulated gust loads, the linkage became overcentered for the neutral initial elevator position tests. Based on the neutral initial position test results, tests of the full TEU initial position were not performed.

### Conclusions: value of sUAS to investigation

#### *Increased efficiency in creating a more accurate 3-D model*

Use of the sUAS to acquire the imagery of the hangar area greatly reduced the time and labor costs required to create a 3-D model of the complex building and terrain environment, which would otherwise require using blueprints, photographs, terrain data (from Google Earth, the U.S. Geological Survey, and/or other sources), and CAD software to manually create the model. For example, it would be difficult to manually create the basic hangar structure alone, but to then add all of the intricate accessories (duct work, chimneys, ladders, detailed architecture, bushes, trees, terrain near the river, et cetera) could take weeks of labor. Further, such a monumental effort still might not provide the level of accuracy needed.

During the process, the NTSB UAS Team learned that some additional manual processing of the 3-D model created by the NTSB UAS Team was required to prepare the mesh data for effective use by the CFD software (such as sealing holes to create a watertight mesh, which is crucial for model stability). This understanding of the steps involved, gained through trial and error, will enable more efficient preparation and processing of future models.

For effective use in the CFD simulation, which has 0.5 meters (1.6 feet) resolution, the input model must have at least that level of accuracy to model small-scale turbulent wind patterns caused by the obstructions. The Boeing CFD specialist believed that, once the processes for preparing a watertight mesh were un-

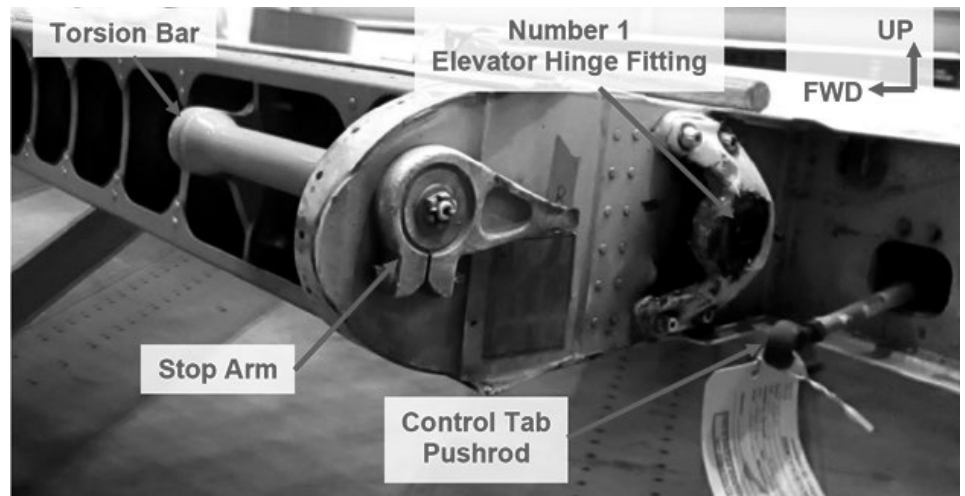

Figure 9. Elevator stop arm and torsion bar assembly.

derstood, using them to refine drone-captured imagery was a superior method compared to other, more crude methods. The Boeing CFD specialist also believed that drone data mesh products enabled the creation of a realistic, high-resolution model that would be difficult, if not impossible, to create manually with acceptable accuracy.

#### *Value of CFD results in developing elevator system testing*

The results of the CFD, including the detailed model of the hangar, greatly increased the confidence in the wind simulation's ability to resolve the microclimate environment sufficiently to draw conclusions about the wind's effect on the airplane's elevator. The visualization of the wind patterns in the vicinity of the tail aided in the development of the test cases, specifically the dynamic test cases. The results from the dynamic test cases helped the investigation understand the interactions of the elevator stop system during an impact-loading condition. Without the CFD study information, questions could have remained regarding whether the flow conditions simulated during the full-scale elevator testing were even possible given the known conditions on the day of the accident.

#### *Future of sUAS use in investigations*

This cooperative and detailed investigation underscored how investigators can and should explore the confluence of modern technologies in furthering their investigations. The sUAS-based imagery, subsequently processed by current generation photogrammetry tools, provided investigators the ability to examine the environment of an accident scene to great

depths. Applications (such as this example) that allow for a detailed microclimate survey (whether affected by a man-made object, as here, or natural terrain) are only the beginning. A rich 3-D presentation of the accident area, with high geographical accuracy, allows for further examination such as geographic information system analysis of airport environments, visibility evaluations, and terrain mapping and modeling. The wind study enabled by this exercise is but one of a multitude of ways to think about all the dimensions of an accident scenario and visualize everything from the overall scene and environment, down to very specific details of items.

Other applications conducted by the NTSB UAS Team include viewpoint reconstructions for both aircraft and surface vehicles, analysis of terrain at both large and small scales, and the development of accident site models that enable investigators the ability to continue to take accurate accident site measurements long after the wreckage has been cleared. The future of accident investigation will certainly take increasing advantage of this revolution in technology; miniaturized, high-resolution cameras and precise positioning and flight plans that provide data for use in affordable, user-friendly processing programs allow investigators to link different facets of their work in new ways. The photogrammetry products developed from these efforts provide investigators with the tools to immerse themselves in the accident evidence better than ever before. The sUAS represents far more than just a means of taking a nice aerial photograph; it is the gateway to deep analysis of the accident environment. ♦

# INVESTIGATING A UNIQUE UAV GEAR COLLAPSE

By James Buse, Senior Technical Lead System Safety, and Jeff Kraus, UAS Flight Test Safety Lead, the Boeing Company

Photo: Boeing



*First flight of the Phantom Eye UAV.*

The Phantom Eye is a one-of-a-kind, liquid-hydrogen-fueled unmanned air vehicle (UAV) test bed designed to operate at high altitude and is capable of long endurance for persistent intelligence, surveillance, and reconnaissance and communications missions—an eye in the sky. The demonstrator aircraft can maintain its altitude for multiple days while carrying a 450-pound payload. Typical payloads include multiple sensor packages for monitoring, tracking, and communications. A full-size Phantom Eye variant is designed to stay aloft for more than a week and carry a payload of 2,000 pounds. The inaugural flight of the demonstrator aircraft was marked a success across all

the planned test points with the exception of the lakebed landing at Edwards Air Force Base in California, USA. The resulting unplanned recovery event threatened the continuance of the flight test program. This paper presents the challenges of investigating an experimental unmanned demonstrator aircraft, lessons learned, and planning preparations to ensure for a successful investigation.

## Description

The Boeing Company's Phantom Eye is a high-altitude/long-endurance (HALE) UAV. There are various operational needs for having a long-endurance air vehicle in

the stratosphere. Examples include battle-field and border observation, port security, or telecommunications, to name a few. The Phantom Eye prototype was designed to stay aloft for five days at an altitude of 65,000 feet without landing or refueling. Specifications of this prototype include

- 150-foot wingspan,
- 45-foot length,
- Empty weight of approximately 6,100 pounds,
- Takeoff gross weight of approximately 8,265 pounds,
- Triplex vehicle management system (VMS) for redundancy,

- All-composite structure,
- Two 2.3L Ford hydrogen engines,
- Three-stage turbochargers, one-stage gearbox, variable pitch, three-blade propellers,
- Two eight-foot diameter vacuum dewar tanks, and
- Liquid hydrogen to gaseous hydrogen heat exchanger.

## First flight timeline

At 6:21 a.m. on June 1, 2012, the Phantom Eye performed a 26-minute first flight, up to 4,000 feet. The following is a high-level overview of the time:

- 6:21 a.m.—Takeoff from lakebed Runway 15, with a transition to normal flight guidance.
- 6:29 a.m.—All systems and performance normal; pilot commanded the aircraft to enter the south lakebed holding pattern per plan.
- 6:36 a.m.—As planned, the pilot manually commanded gear down. Gear extension observed by chase aircraft. Range officer, telemetry pilot display all indicated down and locked gear.
- 6:40 a.m.—Cleared to land,
- 6:47 a.m.—Landing on lakebed Runway 33. Vehicle dynamics were as predicted on final approach. With sink rate on target, the main skid touched down normally followed quickly by nosewheel separating upon contact with the runway and nose strut bending back from drag force, with finally main skid collapse.

## Recovery

After the landing gear collapsed, the air vehicle was in an unknown state. The team needed to use the utmost caution to approach and place the vehicle into a safe state. The telemetry showed no issues or anomalies with the fuel system detected up until the vehicle shutdown. The tank active vent behavior and pressure rise rate following the landing were as expected—once again, up until power off from the vehicle shutdown. Test personnel approached with hydrogen detectors that indicated no hydrogen leakage.

Anything filled with liquid hydrogen should capture and keep your attention as long as it is fueled—even while the engines are off and the vehicle has no power, in what appears to the uninformed observer in a calm state. It is quite dangerous. Pressure is constantly building as the liquid hydrogen warms and turns to gas, constantly increasing the pressure inside the tanks. If the valves stick or moisture freezes the

valves, an overpressure explosion could occur. A great reminder for test personnel approaching and monitoring the state of the air vehicle: “The system is always actively trying to kill you!”

The team needed to ensure there were no leaks of the highly volatile liquid (or gaseous hydrogen) before approaching the vehicle to start the incident investigation along with the defueling and purging process to get into a safe condition. Normal fuel system pressure and expected quantities were verified by the pilot before the launch crew was cleared for approach.

The recovery crew verified there was no fire or leakage using an infrared camera, along with hydrogen detectors. Once confirmed safe for recovery, the mishap plan was initiated at the ground control station with notifications made, data preserved, and statements collected per the premishap plan, and the UAV was recovered from the Edwards Air Force Base lakebed runway to the hangar area for defueling and purging the fuel system.

## Investigation

The mishap occurred on Friday, June 1, 2012. The aircraft was rendered safe and secured, and all evidence was sequestered awaiting arrival of the investigation team to begin the accident investigation process on the afternoon of June 2. The process initiated with a team meeting to understand eyewitness accounts, read statements, discuss the investigative process to include general plan forward, and conduct a site visit to capture lakebed witness mark evidence, including mapping and measuring indentures, skids, and the overall footprint.

The onsite investigation spanned slightly more than one week with many activities occurring in parallel. There were three key activities that contributed to finding the root cause. In no particular order of priority, they were photogrammetry evidence compilation and analysis, design pedigree research, and engineering investigations (EIs). The onsite aspect of the latter consisted of identifying components and arranging logistics for follow-on detailed EIs in the St. Louis, Missouri, metallurgical lab.

## Photogrammetry

The fortunate aspect of conducting flight testing on a range is that you have the luxury of operating in a controlled environment and are afforded the opportunity to build contingency management and data acquisition into the plan. Data acquisition served the program and the investigation quite well. Telemetry data, capturing vehicle performance parameters, became instrumental in aligning witness marks with the vehicle environmental recovery data, which corroborated the evidence captured through the lens of long-range, onboard, and chase

*(Adapted with permission from the authors' technical paper titled Investigating a Unique UAV presented during ISASI 2018, Oct. 30–Nov. 1, 2018, in Dubai, the United Arab Emirates. The theme for ISASI 2018 was “The Future of Aircraft Accident Investigation.” The full presentation can be found on the ISASI website at [www.isasi.org](http://www.isasi.org) in the Library tab under Technical Presentations.—Editor)*



James Buse



Jeff Kraus

video—a trifecta of data that complimented and confirmed the events as they unfolded that Friday morning.

Alignment and agreement of the data were comforting in the final analysis, but the investigation was accelerated in the initial days with the benefit of long-range video recorded in high fidelity. The video evidence permitted review to be slowed to a frame-by-frame basis without introducing the negative pixelating that often hampers video quality. This clarity allowed photogrammetry measurements and assessment to be performed, narrowing the window of speculation as to the mishap's root cause. The significant events that occurred

during the lakebed recovery were easily identified and quickly steered the investigation focus to further delve into the nose landing gear structure, which unveiled further evidence leading to root cause identification.

### Design pedigree

Research into the history of the nose landing gear structure became a primary focus. The examination centered on reviewing the evolution of the design—specifically the latest or current design version compared to the installed version. The drawing revealed an engineering change order initiated circa 1985 stipulating removal of a counter bore. This counter bore proved to be in the origin of the gear failure location.

### Investigation

The EIs consisted of visual and magnified fracture surface inspection and material pedigree review. All visual inspections revealed classic ductile overload fracture. The fracture origin was determined to be on the forward side or zero-degree position of the outer fillet radius between the lower cylinder and the larger diameter upper cylinder. The piston microstructure was normal with no internal defects. No other anomalies were noted at the fracture origin or other elements of the fracture zone. The overload fracture propagated upward through the thickness and outward circumferentially in both directions around the cylinder. Aft bending load from landing drag forces tore the piston lower cylinder with the attached wheel assembly out of the upper piston cylinder. This action resulted in the remaining landing gear stub ultimately collapsing under the balance of remaining frictional forces.

### Investigation summary

The program responded to the first flight anomaly by initiating an accident investigation team and a root cause corrective action team. Both were formed to investigate the incident, determine proximate cause, and recommend corrective actions. The nose landing gear experienced a greater than expected vertical load, but much lower than the maximum specified load that resulted in a piston shaft failure. The greater than expected load was caused by a combination of unexpected bearing friction, piston shaft bending, and increased drag on the main landing gear skid. These unexpected behaviors of the piston were primarily due to two factors. 1) The lack

of dynamic load modeling and testing. Interesting to note that the dynamic load modeling and testing performed postanomaly predicted these failure modes. 2) The piston “as built” configuration did not conform to the “as designed” version, which was due to a failure in the nonconformance review process.

### Recommended actions

There were three recommended actions that came as a product of the mishap investigation and root cause corrective action. The first two were engineering design, and the third was engineering process. First, it was recommended that the nose landing gear be redesigned and that its performance be verified using dynamic load modeling and testing. Second, the main landing gear was further scrutinized via analysis and testing to ensure that adequate landing safety margins existed. Third, conduct a success preliminary and critical design review on the redesigned nose landing gear and main landing gear to include independent subject-matter experts.

### Lesson learned

A lesson learned was test only what you intend to test. In other words, independently verify that each item of the configuration build has the demonstrated credentials to safely support the future test objectives. Trust your baseline engineering data but verify the data to be accurate, current, and representative of the configuration to be tested.

### Challenges

*Vehicle Peculiarities:* Investigating a mishap of a one-of-a-kind aircraft has a unique set of challenges. Although this air vehicle was based on a previous air vehicle and multiple baseline contributors were designed and documented in the 1980s, as a result of an engineering hiatus there was a lack of data for reference due in part to record retention policies. The potential to review past test reports for similar landing gear events or issues was nonexistent. Unlike investigating a production aircraft mishap in which a trove of previous mishap data exists, a one-off air vehicle will have limited or no production data or history to reference.

*Fuel Instability:* The unstable nature of the hydrogen fuel introduced an additional investigation challenge—which comes in the form of evidence preservation. The

instability of liquid hydrogen required the team to defuel the aircraft and purge the lines. As it turned, it was not a factor; however, variables such as fuel contamination or exact weight at landing could have been lost critical data in the pursuit of getting to root cause.

### No pilot first account

Even with onboard cameras, chase, and long-range cameras, there is no “in the seat” or “feel” that an onboard pilot may have during an event. With no voice recorder on board, sounds from the event cannot be detailed as with a pilot or cockpit voice recorder (CVR). The team is limited to onboard telemetry and cameras being functional through the event. *Telemetry Limitations:* In addition to no CVR, the vehicle configuration did not include an onboard crash-survivable data recorder. The team did have live-streamed telemetry data, but it was limited to certain parameters. However, the team had accurate indications of the fuel state along with gear position (down and locked). Had the telemetry stream been disrupted, those indications/confirmations would have been unknown, adding to the complexity of the investigation.

### Key preparation ingredients for a successful investigation

- Controlled test range
- Chase aircraft
- Video (long-range, short-range, airborne, stills, onboard, ground chase, and GoPro™)
- Telemetry
- Lakebed (optional—can conveniently capture witness marks)
- Flight test venue limited exposure to competing users/traffic

### Summary

In recognition, the test team successfully navigated a high-stress, off-nominal first flight event in which the vehicle was recovered safely. The vehicle was repaired and updated with a redesign of the landing gear and flown eight more times, achieving greater altitudes and endurance times with each subsequent flight. Lessons learned were archived for a follow-on version along with passing on additional best practices to future UAV test teams. ♦

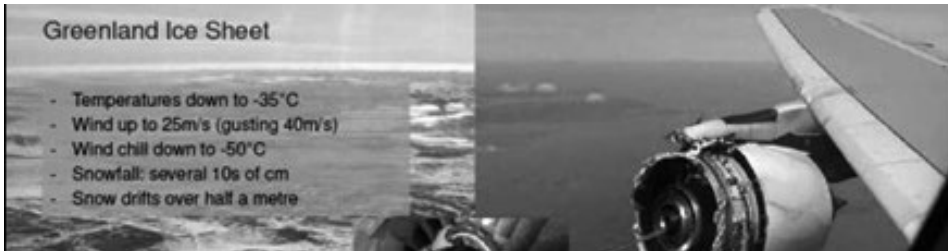

*(Adapted with permission from the author's technical paper titled Application of Innovative Investigation Technologies presented during ISASI 2018, Oct. 30–Nov. 1, 2018, in Dubai, the United Arab Emirates. The author noted that together with his colleague Albert Urdiroz, he has been involved in the investigation of an A380 that suffered a failure on engine No. 4 while in cruise over Greenland on Sept. 30, 2017, which forms the basis of this technical paper. The theme for ISASI 2018 was "The Future of Aircraft Accident Investigation." The full presentation can be found on the ISASI website at [www.isasi.org](http://www.isasi.org) in the Library tab under Technical Presentations.—Editor)*

# APPLICATION OF INNOVATIVE INVESTIGATION TECHNOLOGIES

By Sundeep Gupta, Accident Investigator, Product Safety, Airbus

## Event synopsis

On Sept. 30, 2017, an A380 fitted with Engine Alliance GP7200 engines suffered an uncontained engine failure while cruising at 37,000 feet over Greenland. Engine parts were liberated onto the ice sheet below, including the fan hub, fan blades, and fan casing. The aircraft diverted uneventfully to Goose Bay, Newfoundland, Canada.

Retrieval of the engine components was crucial to understanding the root cause. The key component of interest was the fan hub, a 250 kilogram piece of titanium 80 centimeters in diameter. The fan hub is the central rotating component to which the fan blades are attached. The investigation team faced a huge challenge due to the geography and the extreme climate and looked to technology to help search for the fan hub.

The Annex 13 investigation was delegated by the AIB of Denmark to the French BEA, assisted by accredited representatives and advisors. Airbus, as nominated advisors, deployed resources and technologies to support the investigation and the search for the liberated parts on the Greenland ice sheet.

## Innovative investigation technologies

### Satellite imagery

To visually identify the location of any parts, Airbus immediately launched satellite imagery of a 20 kilometers x 20 kilometers area using the Pleiades satellite constellation, owned and operated by Airbus Defence and Space. The two satellites are in continual orbit around Earth and can be programmed to take images at a resolution of 50 centimeters of any given area in approximately six hours.

The first images received were obscured due to cloud cover (see Figure 1). The satellite continued to take images daily; and over the next few days, the cloud disappeared and we received the first images of the visible ground beneath. However, a blanket of snow had fallen, making it impossible to visually detect any engine parts.

Greenland has a climate in which the snow never melts to its previous level. Only a percentage of the annual snowfall melts each year, meaning any parts covered by snow will never surface again.

While satellite imagery did not provide any tangible results during this investigation, it may prove useful for other events such as locating an accident site in remote or inaccessible areas, mapping large accident sites, or runway excursions. Figure 2 shows an image of flags on the Greenland ice sheet, obtained later in the investigation, that were possible investigation sites captured by the satellite images.

### Ballistic analysis

The potential search zone covers hundreds of square kilometers. To narrow the search area, Airbus advisors worked with Ariane Group spe-

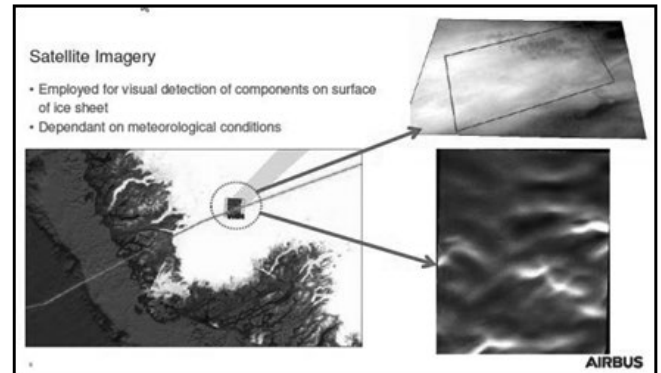

Figure 1. Initial satellite imagery.



Figure 2. Flags on the Greenland ice sheet.

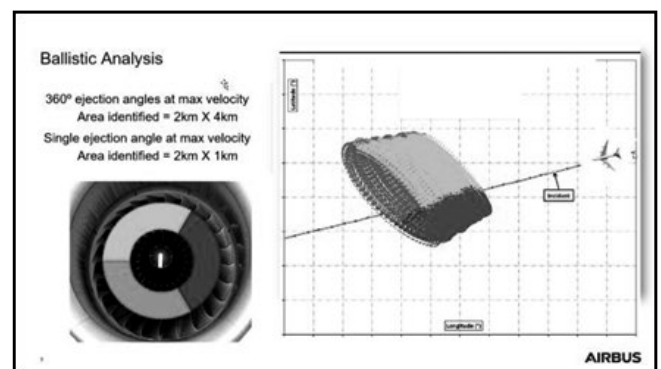

Figure 3. Ballistic analysis of engine fragments helped narrow the search area.

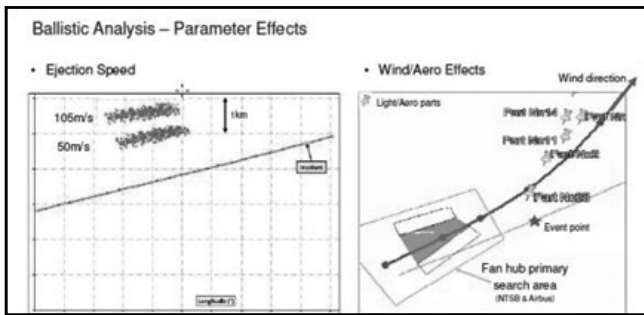

Figure 4. Parameter effects of the liberated parts.

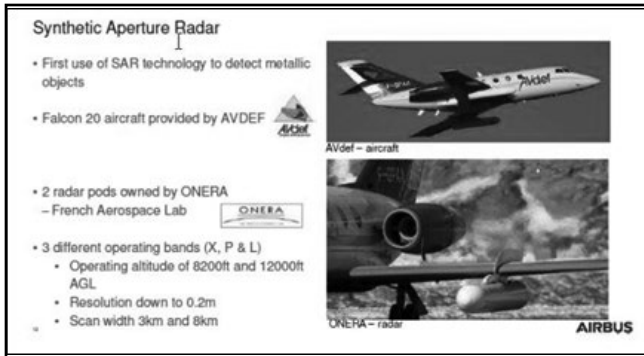

Figure 5. Synthetic aperture radar scanners locate metal objects buried in the snow



Figure 6. A calibration test piece is mounted on a tripod and positioned on a snow-covered golf course with its exact angle and GPS position noted.



Figure 7. A processed image shows the ground and detects the test piece.

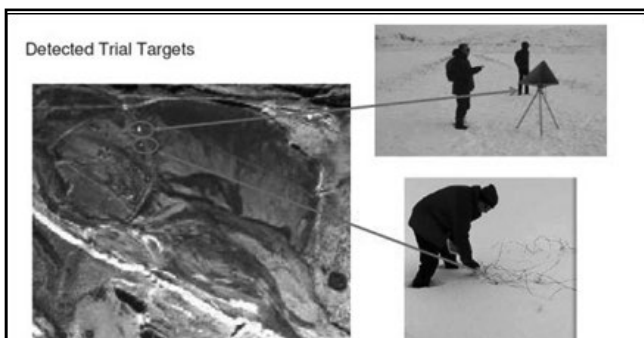

Figure 8. The test reveals a metal fence buried beneath the snow.

cialists to quantify the most likely trajectory of the components from their release at 37,000 feet to landing on the ice sheet.

Examination of the engine revealed that the fan hub had ejected in several pieces. Ariane Group's analytical models (see Figure 3, page 15) were able to narrow the primary search area to 2 kilometers x 4 kilometers when provided with properties of a fragment, such as altitude, aircraft speed, wind, etc.

The ongoing investigation established the fragment ejection angle and ejection speed (see Figure 4). This allowed the area to be refined to 1 kilometer x 2 kilometers. The parameters of the liberated parts influenced the ballistic analysis. Smaller, heavier parts would be projected forward of the event point while lighter, larger parts that have aerodynamic drag would be carried rearward of the event point in the direction of the wind.

The fan hub primary search area shown in Figure 4 was identified using both Ariane and U.S. National Transportation Safety Board (NTSB) ballistic analyses, which were largely consistent. Given the extreme climatic conditions, searching the identified area with ground teams remained a challenge. The investigation team therefore tried to locate the fan hub using airborne radar scanning.

#### Synthetic aperture radar scanning

Synthetic aperture radar is normally used for geographical surveys. This was the first time it would be used to detect metallic objects buried under snow.

ONERA, a French aerospace lab, provided two radar pods equipped with three radars, each scanning at a different bandwidth. These were mounted on a Falcon 20 aircraft provided by AVDEF, part of the Airbus Defence and Space portfolio (see Figure 5).

The team assembled in Greenland and first performed a trial to verify equipment functionality and to calibrate the data to the GPS position.

A calibration test piece was mounted on a tripod and positioned on a snow-covered golf course with its exact angle and GPS position noted (see Figure 6). The aircraft overflew the area at the two radar operating altitudes to capture the landscape with all three radar bands.

Once the image was processed, the radar scan revealed the ground beneath the snow and ice (see Figure 7).

Examination of the image confirmed that the test piece had been detected, indicated by a bright white return on the radar image. A second radar return was seen on the image in the vicinity of the test piece. The cause of this return was not known and when the team returned to the site, metallic fencing wire buried under the snow was discovered (see Figure 8).

This demonstrated that the technology was fundamentally capable of detecting metallic objects even when buried under snow.

An extensive area for the hub search was scanned and data was collected. However, crevasses were present within the area and created background noise in the radar data. The radars were able to scan about 36 meters below the surface of the ice.

Figure 9 shows an area approximately 4 kilometers x 2 kilometers. Each of the 200 million pixels, each covering 20 centimeters<sup>2</sup> in X-Band, was scanned by a total of 72 images at different angles and polarizations.

The large amount of data underwent complex posttreatment to differentiate crevasse returns and background noise from credible fan hub targets.

#### 3-D laser scanning

Shortly after the event, the BEA and AIB of Denmark scrambled helicopters along the aircraft track before more snow fell and were able to



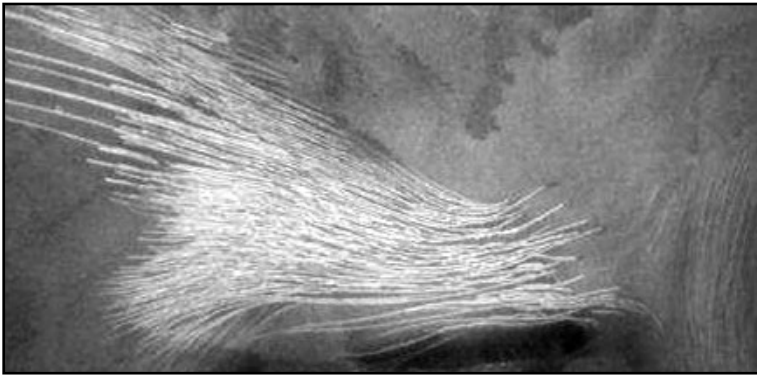

Figure 9. This image shows an area approximately 4 kilometers x 2 kilometers.

locate and recover the larger, aerodynamic engine components that had been liberated during the event. Due to their size, they were easier to spot by the helicopter crew (see Figure 10).

With their aerodynamic properties, these components were blown rearward of the event pointing in the direction of the wind, whereas the fan hub trajectory was analyzed to have landed in front of the event point.

Because the fan hub had not been located, the investigation team needed to ensure that maximum data was extracted from these recovered parts. The data would also support any hypothesis put forward and validate any analysis.

Airbus deployed the use of state-of-the-art 3-D scanning technology provided by IDLAB, a subsidiary of Airbus commercial (see Figure 11).

Using 3-D laser scanning equipment, all of the parts were digitized, creating 3-D models of the retrieved components and capturing details with an accuracy of 0.03 millimeters.

The scanned data allowed an assessment of which parts had been recovered and which remained on the ice sheet. A 3-D reconstruction was produced, which provided insight as to how the engine event may have unfolded (see Figure 12).

In addition, 3-D models can be overlaid to reference data such as Catia models or scans of reference parts to analyze how a part became distorted or deformed (see Figure 13).

3-D scanning can provide an accurate record of parts as they are recovered and before any disassembly or destructive testing takes place. The data can be made available to all parties of the investigation so that analysis can begin simultaneously. The data can be imported into Catia or viewed as a 3-D pdf model. Any hypothesis can be cross-checked against this 3-D data.

## Summary

The investigation team led by the BEA has been working hard to move the investigation forward. The engineering analysis to date has allowed mitigating actions to be taken on the A380 fleet powered by Engine Alliance GP7200 engines. The investigation, search, and analysis continue.

When Airbus is engaged in an investigation, along with Airbus commercial, we can also engage the resources and expertise of Airbus Helicopters and Airbus Defence and Space domains.

By utilizing the resources from across the Airbus Group, Airbus advisors have been able to deploy a number of innovative technologies to gain the maximum amount of knowledge possible from the components already retrieved and to locate the fan hub, the key component of the investigation. ♦



Some engine parts recovered in Greenland

Figure 10. The BEA and AIB of Denmark use helicopters to locate and recover the larger, aerodynamic engine components.

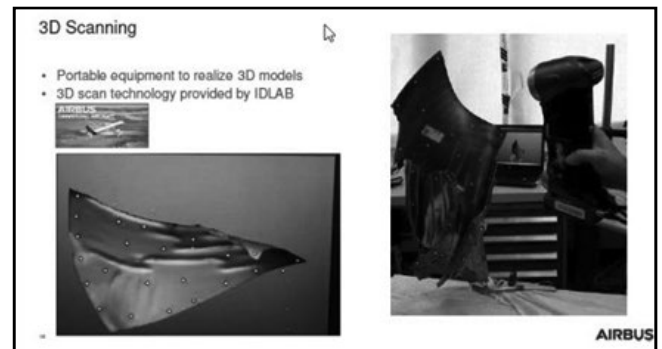

Figure 11. Airbus uses state-of-the-art 3-D scanning technology to create 3-D models of the retrieved components.

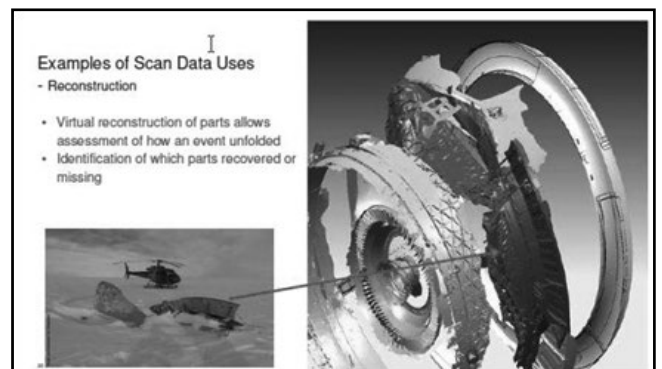

Figure 12. A 3-D reconstruction was produced, providing insight as to how the engine event may have occurred.

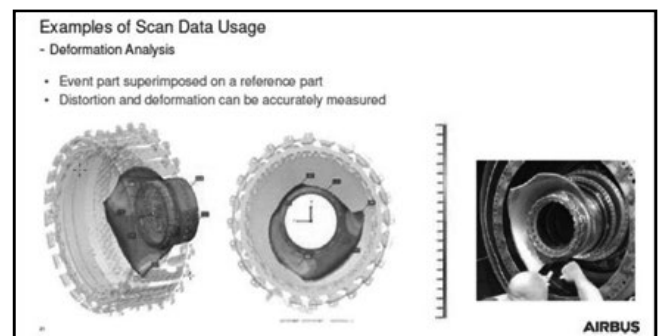

Figure 13: 3-D models can analyze how a part becomes distorted or deformed.

# 5 MILLIMETER CRACK LEADING TO AN ENGINE FIRE

By David Lim, Principal Investigator, Transport Safety Investigation Bureau, Singapore

## Synopsis

On June 27, 2016, a B-777-300ER departed Singapore for Milan, Italy. About two hours into the flight, the right engine indication showed low oil quantity. Subsequently, the flight crew felt a vibration in the control column and cockpit floor and decided to return to Singapore.

Shortly after landing at Changi Airport, a fire occurred in the vicinity of the aircraft's right engine. After the aircraft came to a stop on the runway, a fire developed under the right wing. The airport rescue and firefighting (ARFF) service extinguished the fire. Damage to the aircraft included heat damage to the core of the engine, portions of the engine cowlings, and the wing area directly behind and outboard of the right-hand engine.

The Transport Safety Investigation Bureau conducted the investigation into this occurrence with the assistance of the U.S. National Transportation Safety Board, the U.S. Federal Aviation Administration (FAA), and the aircraft and engine manufacturers.

The information in this paper details the findings and other aviation safety aspects deliberated during this investigation.

## Background of Flight

A B-777-300ER departed Singapore's Changi Airport at 2:24 p.m. for Milan on June 27, 2016. The aircraft carried two sets of operating crew—four pilots in total.

As the aircraft was climbing to its cruising altitude, the flightcrew members en-

countered weather that required them to perform weather-avoidance maneuvers. About 30 minutes into the flight, when the aircraft had climbed to 30,000 feet, the flight crew noticed that the oil quantity parameter in the engine indicating and crew alerting system (EICAS) showed 17 units for the left engine but only one unit for the right engine. The flight crew also noticed from the EICAS display that the right engine oil pressure was fluctuating between 65 and 70 pounds per square inch (psi) while the oil temperature for the right engine was 10 degrees Celsius higher than the left engine. However, both the oil pressure and temperature parameters were within the normal operating range.

The flight crew looked through the available manuals but was unable to find an appropriate procedure that addressed the low engine oil quantity situation.

At 3:04, the pilot-in-command (PIC) contacted the company's engineering control center for assistance via satellite communication. The PIC informed the engineer on duty of the engine parameters and asked if it was safe to continue the flight. The engineer informed the PIC that since the oil pressure was within the normal operating range, there could be a faulty oil quantity indication. The engineer advised the PIC to continue with the flight but monitor the right engine oil parameters. The engineer told the PIC that he would also contact the company's technical services personnel for advice.

After being briefed by the engineer

on the situation, the technical services personnel believed that it was a faulty oil quantity indication. As the aircraft had just departed and was not far from Singapore, the technical services personnel recommended that the aircraft return.

According to the flightcrew members, as they were passing waypoint VPG at approximately 3:20 p.m., the first officer performed a routine fuel quantity check. After comparing the totalizer fuel quantity with the planned fuel remaining quantity, it was determined that the fuel consumption was better than expected as the fuel on board was 600 kilograms more than the expected value.

At 3:28 p.m., the engineer sent a message via the aircraft communication and reporting system (ACARS) to the flight crew relaying the recommendation of the technical services personnel for the aircraft to return to Singapore and requesting the crew to contact the engineering control center.

The PIC contacted the engineering control center, and a conference call among the PIC, the engineering control center, and the technical services personnel was held, which lasted about 20 minutes. The PIC noted that the flight crew had been monitoring the right engine oil parameters for 50 minutes; other than the indicated low oil quantity, the parameters appeared normal. It was jointly assessed that the flight could continue to Milan with the proviso that the flight crew monitor the right engine oil parameters and contact the engineering control center for



assistance if needed.

Shortly after the conference call ended, the flight crew felt an unusual vibration in the control column and cockpit floor. The crew tried to diagnose the problem by changing the engine power settings and found that the vibration disappeared when the power of the right engine was reduced. At about the same time, the flight crew caught a momentary wisp of a burnt smell in the cockpit, but the smell disappeared quickly.

At 4:04 p.m., the PIC informed the engineering control center about the vibrations experienced whenever the right engine was operated at higher power settings. In the ensuing conference call among the PIC, the engineering control

center, and the technical services personnel, it was assessed that there was no need to shut down the right engine and decided that the aircraft would return to Singapore with the right engine operating at idle power. In the midst of the conference call, the in-flight supervisor (IFS) informed the flight crew that there was a burnt smell detected in the cabin. In response, the flight crew turned off the right engine bleed system.

According to the cabin crew, the smell was particularly strong in the business-class cabin, in the forward part of the aircraft. The cabin crew distributed wet towels for the passengers to hold over their nose and breathe through.

After the conference call ended, the

*(Adapted with permission from the author's technical paper titled 5 mm Crack Leading to an Engine Fire—Lessons Learned presented during ISASI 2018, Oct. 30–Nov. 1, 2018, in Dubai, the United Arab Emirates. The theme for ISASI 2018 was “The Future of Aircraft Accident Investigation.” The full presentation can be found on the ISASI website at [www.isasi.org](http://www.isasi.org) in the Library tab under Technical Presentations.—Editor)*

<i>Time</i>	<i>Party Speaking</i>	<i>Content</i>
6:51:50 p.m.	PIC	How is it looking? Is the fire contained?
6:51:53 p.m.	FC	We are still trying to contain the fire... The fire is pretty big... Will like to advise... disembarkation on your port side.
6:52:05 p.m.	PIC	Okay, evacuate from the port side confirm.
6:52:09 p.m.	FC	Still trying to contain the fire... Still some random fire on your right-hand engine, but we are keeping it under control.
6:52:24 p.m.	PIC	Do you need us to evacuate from the port side?
6:52:29 p.m.	FC	Singapore 368 standby, standby.
6:52:33 p.m.	PIC	Okay standby for your instructions Singapore 368. Standby for your instructions.



David Lim

Time	Party Speaking	Content
6:54:08 p.m.	FC	<i>We have kept the fire under control. We will like to advise disembarkation on your port side.</i>
6:54:20 p.m.	PIC	<i>Okay, you want us to disembark through the slides or are you going to provide mobile stairs?</i>
6:54:38 p.m.	FC	<i>We will like to advise disembarkation on your port side.</i>
6:54:48 p.m.	PIC	<i>Okay, you want us to disembark on the port side through the emergency slides. Can you confirm that?</i>
6:55:14 p.m.	PIC	<i>Can you just confirm that we need to evacuate through the left through the emergency slides?</i>
6:55:33 p.m.	FC	<i>Negative, negative, negative. We will like to advise disembarkation, disembarkation. No evacuation, no evacuation.</i>
6:55:42 p.m.	PIC	<i>Okay, disembarkation through mobile steps understand, understand.</i>

flight crew reduced the right engine to idle power and proceeded to turn the aircraft around to return to Singapore. For the return journey, the flight crew adopted the procedure for single-engine operation, including a descent to 17,000 feet before reducing the right engine to idle power.

When the IFS informed the flight crew that the burnt smell in the cabin was still present, the right air conditioning pack and recirculating fans were switched off. Shortly after, the smell in the cabin subsided.

At 5:21 p.m., the flight crew received a fuel disagree message on the EICAS. The flight crew performed the fuel disagree checklist, which suggested four scenarios in which a fuel leak should be suspected and when the flight crew should perform the fuel leak checklist. One such scenario

is when the totalizer fuel quantity is less than the calculated fuel quantity.

The flight crew observed from the display of the flight management system that totalizer fuel quantity was about 79 tonnes, and the calculated fuel quantity was about 83 tonnes.

However, the flight crew did not perform the fuel leak checklist. According to the flightcrew members, they believed the calculated fuel quantity was no longer accurate in view of the following:

- Input changes had been made to the flight management system after the right engine was set to idle power.
- They were no longer on the planned flight route.
- They had 600 kilograms more fuel than expected when they last performed a routine fuel check.

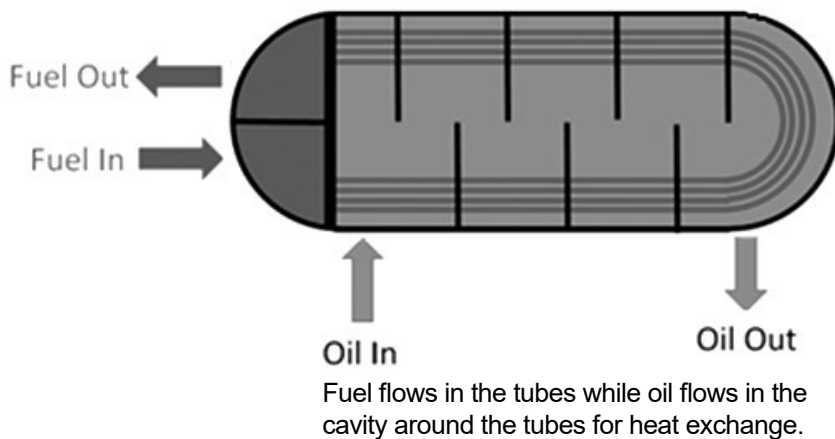

Figure 1. Schematic diagram of the main fuel oil heat exchanger.

Thus, the flight crew performed its own fuel calculation by subtracting the amount of fuel consumed from the total amount of fuel at the start of the flight. The fuel consumed was calculated by multiplying an average fuel flow value (that the flight crew determined) by the duration of the flight. The crew arrived at a figure of about 79 tonnes. As this tallied well with the totalizer fuel quantity figure, the flight crew concluded that the fuel disagree message was a spurious one and that there was no need to proceed with the fuel leak checklist.

Several times on the return journey and as the aircraft approached Singapore, the flight crew was queried by air traffic control (ATC) if it needed any assistance. The flight crew replied that, other than the need to fly at the lower altitude of 17,000 feet, no assistance was needed as all other operations were normal.

Prior to landing, the flight crew jettisoned about 41,500 kilograms of fuel to bring the aircraft to below its maximum landing weight.

At 6:49 p.m., the aircraft landed on the runway. About 20 seconds after the thrust reversers on both engines were deployed, the occupants in the cabin heard two loud bangs, accompanied by two flashes, originating from the right engine area. At the same time, the flight crew heard a soft thud. The ARFF personnel who were monitoring the aircraft's arrival informed the control tower about the fire at the right engine. The control tower informed the flight crew of the fire and instructed the aircraft to stop at the intersection between the runway and rapid-exit Taxiway E7. The flight crew did not receive any fire warning in the cockpit.

### Response to fire

ARFF, which was on standby with four foam tenders and one water tender, entered the runway as soon as clearance to enter was given by the control tower. The first foam tender arrived on scene after 57 seconds and started discharging foam at the right engine.

When responding to the fire, the fire commander (FC) of the ARFF requested the control tower to ask the flight crew to switch the aircraft radio to the emergency channel for communication between the FC and flight crew.

Subsequently, the FC and PIC established communication on the emergency

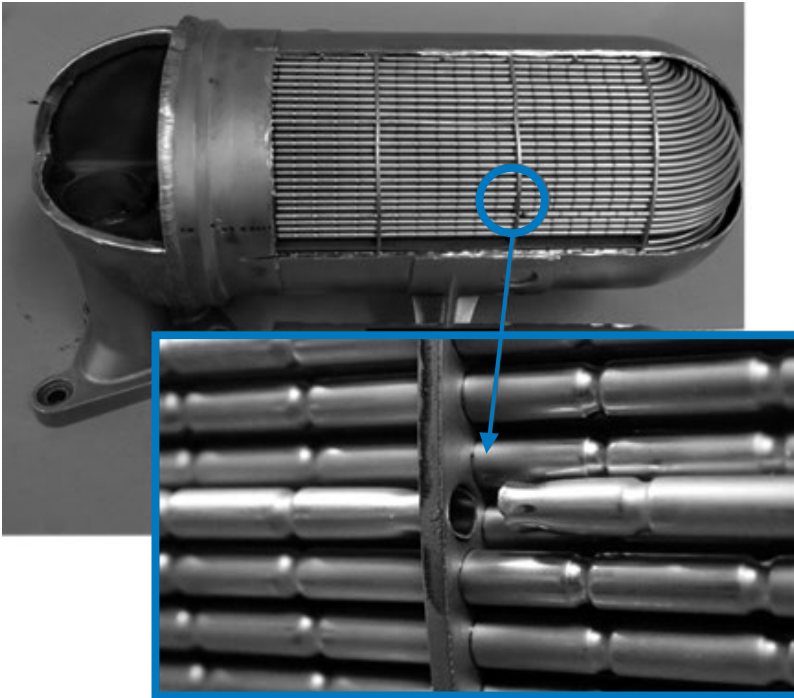

Figure 2. View of cracked tube in the main fuel oil heat exchanger.

channel, and key exchanges occurred (see page 19).

Jet fuel that was discharged from the right engine onto the tarmac fueled a fire that impinged on the underside of the right wing near the right engine area.

ARFF managed to bring the fire under control and put out the visible fire in the right engine area and on the ground at 6:53. However, ARFF personnel, using an infrared detector, found a heat signature within the internal section of the engine and continued to monitor the situation. Key exchanges between the FC and PIC at that point occurred (see page 20).

About three minutes later, the fire appeared again at the forward section of the right engine. It was immediately put out by ARFF. There was no fire warning in the cockpit when the flight crew was informed of the ongoing fire by the FC. The flightcrew members eventually discharged both the bottles of fire extinguishing agent into the right engine when they were queried by the FC if they had discharged the bottles. Eventually, after the FC had assessed the situation to be safe and that the fire was brought under control, the occupants of the aircraft disembarked via mobile stairs.

### Damage to aircraft and engine

The right wing and engine area of the aircraft sustained extensive damage. The most extensive damage to the right wing was in the vicinity of the right engine. Fire damage was also observed on the underside of the right wing, outboard of the engine. The fan section, variable bleed valves (VBVs), and high-pressure compressor (HPC) of the right engine sustained varying degrees of heat damage.

### Cause of fuel leak

During the initial postoccurrence examination of the right engine, fuel was found in the booster spool cavity, oil tank, all bearing sumps, and accessory and transfer gearboxes. These were areas of the engine where fuel should not be present during normal operation.

The main fuel oil heat exchanger (MFOHE), a component that is used

by both the engine fuel and oil system, was examined for the presence of an internal leak. The MFOHE contains a series of tubes. Fuel flows in these tubes, while oil used for lubricating the engine flows around the tubes (see Figure 1). This allows oil to be cooled through heat transfer to the fuel through the tubes. The design of the MFOHE is such that the oil and fuel flow paths will not cross, and the oil and fuel will not come into contact with each other.

The MFOHE was removed from the engine, and the preliminary pressure tests performed on it confirmed an internal leak between the oil and fuel flow paths. The MFOHE was sent to the engine manufacturer's facility where a computer tomography scan was performed. The scan results showed that there was a cracked fuel tube that was displaced.

The MFOHE was then sent to the manufacturer's facility for further examination. In a test performed to simulate the operation of the MFOHE at idle engine power setting, the leak rate from the displaced cracked tube was found to be about 31 pounds per minute. A portion of the MFOHE casing was removed. One of the fuel flow tubes was found cracked and displaced (see Figure 2).

1. The cracking of a tube in the MFOHE allowed fuel in the fuel flow path of the MFOHE to flow into the oil flow path in the MFOHE. The investigation has not revealed other sources of fuel leak.
2. During all phases of the engine fuel pump operation, fuel is delivered at pressures between 400 and 1600 psi. In comparison, the pressure within the engine oil system is about 100 psi. As such, when the fuel carrying tube in the MFOHE cracked, the higher pressure fuel entered the engine oil distribution system.
3. During the normal operation of the engine oil system, a small amount of oil will collect in the A sump. However, when fuel leaked into the oil system, it filled the A sump until its maximum storage capacity. The additional quantity of leaked fuel overflowed into the booster spool cavity and started to collect there (see Figure 3, see page 22).

Once the booster spool cavity was filled to the aft lip, the excess fuel leaked through a gap between the spool and aft stage booster vane into these areas (see Figure 4, see page 23):

- HPC through the core airflow.
- Fan duct when the VBV doors are open at engine idle power.

The oil tank and various engine drain points are areas in which one would usually expect to find only oil. Instead, fuel was found in those locations. Similarly, residual fuel was found in the various engine sumps. In addition, the gearboxes and the engine bearings, which are usually coated in oil, were dry. These observations suggest that engine oil was displaced from the engine and fuel, in place of oil, was distributed throughout the engine oil system.

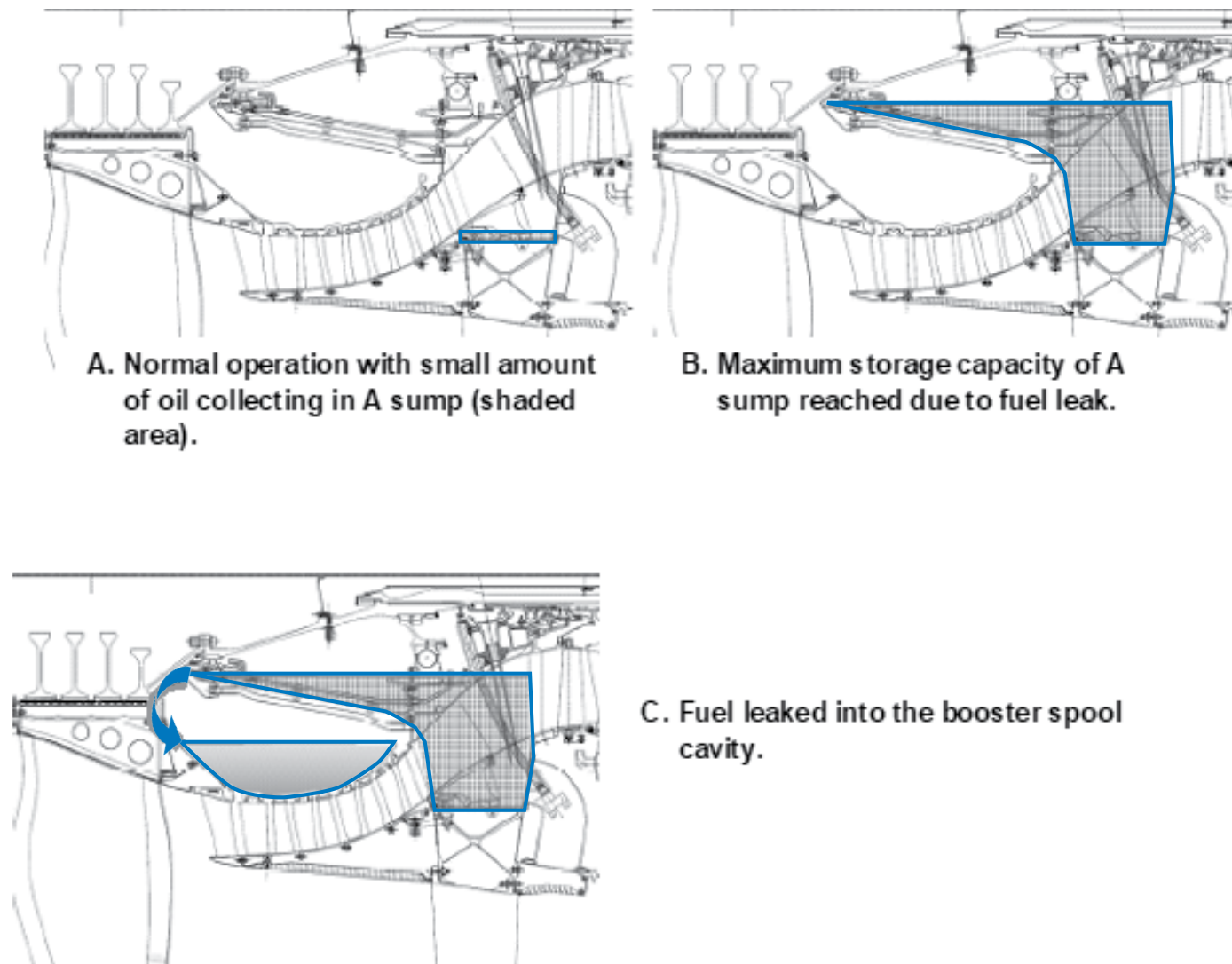

*Figure 3: Process of fuel filling the A sump and booster spool cavity.*

Engine oil lubricates and cools the engine bearings and gearboxes and helps to lower vibration at the engine bearings. Fuel is not as efficient as oil for engine lubrication. Therefore, when oil had been displaced by fuel in the occurrence engine, oil temperature increased. The temperature increase was a result of fuel in the oil system that was not able to cool the engine bearings and gearboxes as efficiently as oil.

The vibration detected by the flight crew when operating the right engine at a higher power setting was likely due to the fuel that collected in the booster spool cavity. This cavity is a dome-shaped space, and rotational forces would have caused the fuel to be spun against the inner wall of the booster spool cavity as the engine was operating. The rotating fuel created imbalance that resulted in vibration. At higher engine power settings, the vibration would have been more pronounced as compared to the engine at idle opera-

tion. This was consistent with the flight crew's observation that the vibration seemed to disappear when the engine was at reduced power setting.

For the remainder of the return journey back to Singapore, fuel leaked through the core of the engine and the fan duct. As the engine was operating at idle power, the VBV's were open, allowing the leaked fuel into the VBV ducts and the fan duct, where it could accumulate in the honeycomb core material behind the perforated walls of the thrust reverser duct.

### Fire initiation and propagation

The investigation team determined that the fire was a result of hot surface ignition of leaked fuel at the area behind the turkey feather seal of the core exhaust nozzle. Based on recorded video and data from the aircraft, the investigation team believed that the fire first started after the thrust reversers were deployed during the

landing.

There was no fire during the airborne segment of the aircraft's return journey to Singapore. This was due to the high velocity of the airflow over the exterior of the engine, which prevented both the ignition and sustained combustion of the leaked fuel.

As the aircraft arrived to land, fuel was still leaking from the engine through various leakage areas (see Figure 4). When the thrust reversers were deployed, the velocity of airflow over the core exhaust nozzle was significantly reduced. The area aft of the turkey feather seal, which is a protrusion on the core exhaust nozzle, would have experienced the most significant disruption of airflow. In addition, the accumulated fuel in the fan duct was also distributed over a wide area of the lower surface of the wing.

The investigation team believed that, with the disrupted airflow, the mixture of accumulated fuel on the core exhaust

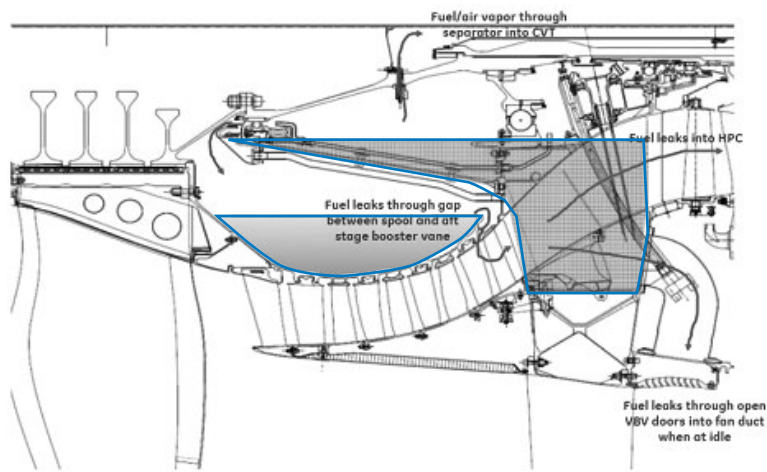

Figure 4: Leak path for fuel.

nozzle and fuel in the airflow would have been sufficiently heated to the point of ignition. Subsequently, the fire propagated through these following areas of the engine:

- fan duct,
- thrust reverser blocker doors,
- booster,
- HPC, and
- VBV.

As the engine was spooling down, the excess fuel that had been collected in the booster spool cavity was discharged through the fan duct and flowed onto the runway and caught fire. The fuel that was distributed over a wide area of the lower surface of the wing also caught fire.

### Design of MFOHE

The MFOHE was designed and manufactured by a component manufacturer that supplied it to the engine manufacturer. It was designed to have unlimited service lifespan, i.e., periodic replacements would not be needed. The engine manufacturer did not require any periodic inspection of the internal portion of the MFOHE during its service lifespan.

The manufacturing process involves crimping, a process in which a force is applied to achieve a slight deformation of a material. The purpose of crimping is to deform the cross-sectional shape of the tubes so that they cannot slide freely through the round holes of the support plates. This prevents the support plates from moving during assembly (see Figure 5, see page 24).

### History of MFOHE leakage

According to the MFOHE manufacturer, prior to December 2013, there had been nine instances of leaking MFOHEs on GE90-115B engines that were returned to the MFOHE manufacturer for repair. The causes of the leakages in these nine MFOHEs, which would have required destructive examination, were not determined.

Between December 2013 and February 2014, the MFOHE manufacturer received three MFOHEs from GE90-115B engines that were suspected to be leaking. The engine and MFOHE manufacturers jointly decided to conduct destructive examination of these three units. It was found that two MFOHEs had a partially cracked tube. The cracks were at the crimped areas of the tubes. At that point, the cracks were attributed to the stress concentrations created at the support plate hole edges resulting from the crimping operation. The third unit had a tube with a pinhole leak.

In April 2014, the engine and MFOHE manufacturers conducted a review of the manufacturing operations. Improvements to the manufacturing process were made in May 2014. The improvements included using a standardized crimping tool to eliminate the variation in the crimps due to the use of hand tools. In addition, the crimped fuel tubes that have a history of cracking will be welded close at assembly.

The MFOHE manufacturer received another MFOHE unit from a GE90-115B engine suspected to be leaking that was removed from service in June 2014. This unit was manufactured before the improved manufacturing process was implemented. Destructive examination revealed a partially cracked crimped tube,

in the same location as the previous two units examined.

In August 2014, a B-777-300ER installed with GE90-115B engines and operated by another operator experienced after landing and engine shutdown a small, candle-wicking-like fire emanating from its left engine center vent tube. Teardown of the MFOHE revealed that fuel had entered the oil system through a cracked tube. This MFOHE was manufactured before the improved manufacturing process was implemented.

The cause of the crack in the August 2014 event was determined by the engine and MFOHE manufacturers to be the variation in the crimp on the tube that resulted in contact between the support plate and crimped tube. The contact resulted in stress concentration that could have led to crack initiation.

The August 2014 occurrence led the engine manufacturer to introduce a diagnostics program to monitor oil consumption trends. After an aircraft has landed, the aircraft operator will send the engine data related to the preceding flight to the engine manufacturer for analysis by the diagnostic program. Should the diagnostics program detect any abnormal oil consumption trend related to a suspected fuel leakage into the oil system, the operator will be alerted by the engine manufacturer.

In a failure analysis test conducted by the engine manufacturer in September 2016, it was further discovered that unintended diffusion bonding occurred during the manufacturing process of the MFOHE when elevated heat was applied. It was identified that the diffusion bonding occurred at the areas where there was close contact between the tubes and the support plates.

During normal operation of the MFOHE, stress was introduced at the fused area that ultimately led to the tube cracking. It was also determined that crimping increased the likelihood and severity of diffusion bonding to occur.

### Resolution for cracked tube problem

As part of its airworthiness control system, the FAA, the regulatory authority for U.S. aeronautical products, requires engine manufacturers to identify unsafe conditions and implement corrective actions.

The FAA offered a process known as

continued airworthiness assessment methodologies (CAAM) to help engine manufacturers identify potential unsafe conditions associated with their products. CAAM also helped engine manufacturers determine if the potential unsafe conditions were likely to exist or develop in other products of the same type design.

The engine manufacturers may use CAAM to

- assess the risk associated with the unsafe conditions.
- develop and prioritize appropriate corrective actions to address the unsafe conditions.
- assess the effectiveness of the corrective actions.

Under the CAAM process, each occurrence would be accorded a severity level. The severity ranges from Level 1 (minor) to Level 5 (catastrophic). The determination of the CAAM level was based on the actual damage and consequences in the occurrence. The CAAM level of a possible future occurrence was then assessed and used to determine the urgency to implement corrective actions. The unsafe conditions identified and the corrective actions determined had to be approved by FAA before being implemented.

The small candle-wicking fire occurrence in August 2014 was categorized as a CAAM Level 2 event by the engine manufacturer.

Following its investigation into the August 2014 event, the engine manufacturer issued Service bulletin (SB) 79-0034 in December 2014 to address the issue of fuel leakage into the oil system. The SB required the MFOHE to be removed from the engine no later than the next occasion when the engine was in an engine shop for engine shop maintenance. The deadline for compliance with the SB was set in accordance with the CAAM consistent with a Level 2 criticality.

As required by SB 79-0034, the MFOHEs were to be sent back to the MFOHE manufacturer to check for leakages. Should a leakage be detected, the openings at the entrance and exit of the leaking tube would be welded close to prevent fuel from flowing into it. Crimped tubes that had a history of cracking will also be welded close, regardless of whether the MFOHE was found leaking.

In response to an immediate safety recommendation made by the investigation team, the deadline for compliance

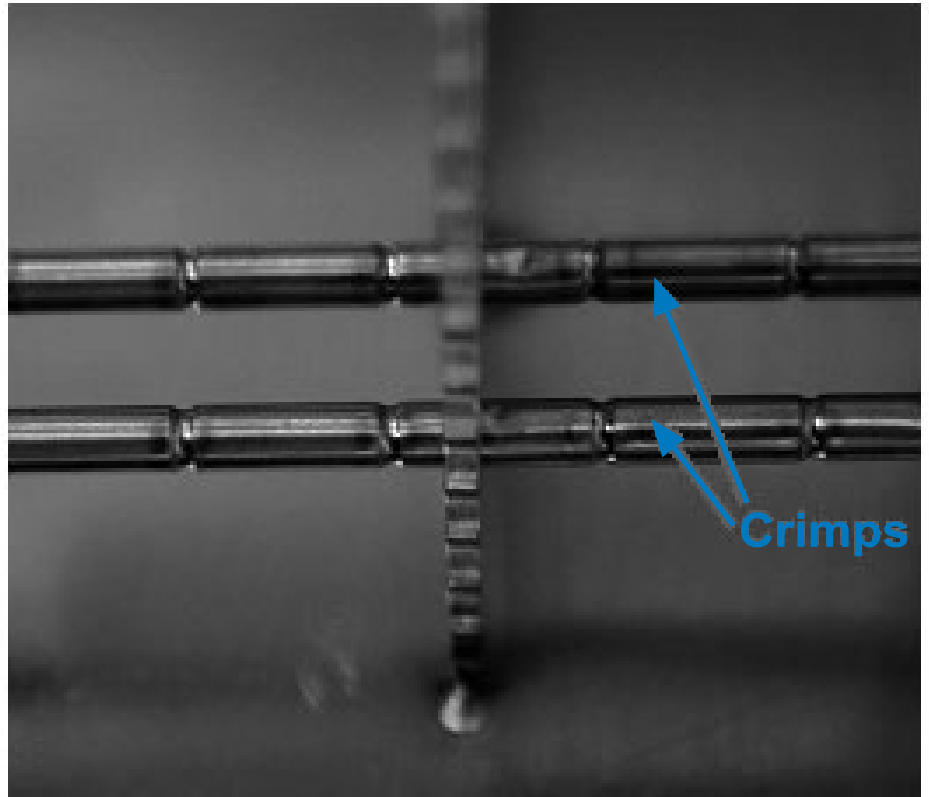

Figure 5. Crimps on tubes.

with the SB was brought forward. The actions called for by the SB were performed on all affected MFOHEs by July 2017.

### Timeliness of safety improvement implementation

At the time of the occurrence, the actions called for by SB 79-0034 had not yet been performed on the occurrence engine. The engine had last undergone an engine shop maintenance in March 2014, before the SB was issued.

Had the SB been incorporated in the occurrence MFOHE, the fuel leak would not have occurred and the fire event would have been avoided.

Despite the engine manufacturer following the CAAM, which was provided by the FAA, a fuel leak in the MFOHE due to a cracked tube recurred and resulted in a more severe consequence of an uncontrolled fire.

This occurrence suggests that there is room for civil aviation authorities to review and enhance, if necessary, their control system to ensure that corrective actions can be implemented more expeditiously to prevent the recurrence of unsafe conditions.

Undoubtedly, implementation of safety improvement measures often results in

additional costs and operational constraints for stakeholders in the aviation industry. In such situations, civil aviation authorities will have to balance the needs of promoting growth of the aviation industry and to ensure the safety of the flying public.

### Decision-making during abnormal situation

In the initial communication, the FC advised the PIC, “We are still trying to contain the fire.... The fire is pretty big.... Will like to advise...disembarkation on your port side.” As the commander of the aircraft, the PIC was aware that the decision to evacuate lay with him and that he could order an evacuation even if the FC advised a disembarkation. Although the PIC was the only person actively communicating with the FC, the other flightcrew members were listening to the communication and the decision not to evacuate was reached collectively.

Making a decision to evacuate is not always straightforward:

- On the one hand, the operator’s flight crew training manual recommends that in a situation in which a persistent smoke or a fire cannot positively be confirmed to be completely extinguished, the safest course of action



typically requires the earliest possible descent, landing, and evacuation. The manual also recommends that pilots should utilize all available sources of information in making a decision regarding evacuation. The manual also highlights that key factors to be considered include the urgency of the situation (e.g., possibility of significant injury or loss of life if a significant delay occurs). The manual also recommends that, in case of doubt, an evacuation should be considered.

- On the other hand, the operator's flight crew training manual also recognizes that fire may be spreading rapidly from spilled fuel or other flammable materials, which may endanger the people who have left the aircraft or are still on the escape slides.

The flight crew will have to balance the pros and cons of a decision to evacuate given the situational picture that it has. It cannot be overemphasized that the flight crew needs to exhaust all possibilities and all available resources to try to build a situational picture that is as accurate as possible.

In this occurrence, there were a number of resources that were not used by the flight crew but that could have been of help.

- *Taxiing camera system*

The aircraft was equipped with a system of cameras installed at various locations to assist the flight crew in taxiing. If switched on, the system could have provided real-time video of the exterior of the fuselage. There was one camera installed on the leading edge of the right horizontal stabilizer. This camera could provide the flight crew with a vantage view of the fire. According to the flight crew, it would usually switch on this camera system when taxiing the aircraft, as required by the operating procedures. However, in this occurrence, the crew did not switch on the system because it had not reached the taxiing phase as the crew had been instructed by ATC to stop at the intersection between the runway and rapid-exit Taxiway E7.

- *Cockpit escape window*

The flight crew could have opened the cockpit escape window on the right side to find out the situation outside. Extending the upper body out of the right escape window would allow a person to obtain a view of the fire situation at the right wing

and engine area.

- *Cabin crew*

The cabin crewmembers could have had a view of the fire situation at the right wing and engine area through the cabin windows. The flight crew could have asked the cabin crewmembers what they could see. According to the PIC, the flight crew was aware that cabin crew members were a source of information throughout the occurrence. However, the flight crew was not able to attend to every call from the cabin crew as it had to prioritize tasks. In terms of obtaining information on the fire, the flight crew gave priority to the task of communicating with the FC as he was the subject-matter expert and would have a better assessment of the fire from his location outside the aircraft.

Admittedly, the situation that the flight crew faced was a stressful one. In trying to decide whether to evacuate, the crew was further disadvantaged as there was no indication of fire from the aircraft's fire detection system. The fire detection elements were shielded from the fire by the engine cowlings, and there were no fire detection elements located outside the engine cowling. There was also no guidance in the manuals available to the pilots when there is a reported fire, but the aircraft fire detection systems did not indicate so.

In that situation, the flightcrew members depended on the FC as the sole source for information collection, and it may have slipped their minds to consider alternative ways of gathering information. Research has shown that decision-making under stress may become less systematic and more hurried and that fewer alternative choices are considered. The flight crew's behavior was consistent with the research findings.

It is recognized that it may not be possible for an operator to practice its pilots on checklist response for all possible emergency and abnormal situation scenarios. It is therefore all the more critical that pilots develop the ability to always consider alternatives and other resources when they encounter a situation that is not dealt with by any checklist.

### Execution of infrequently used checklist

The fuel disagree message that the flight crew encountered was a result of the fuel leak after the tube had cracked in the

MFOHE. The fuel disagree checklist suggested four scenarios in which a fuel leak should be suspected and thus the fuel leak checklist should be performed. One such scenario is when the totalizer fuel quantity is less than the calculated fuel quantity. Given that the totalizer fuel quantity was about 79 tonnes and the calculated fuel quantity about 83 tonnes, the flight crew should have concluded that it had to proceed on to the fuel leak checklist.

As mentioned, the flight crew's own assessment and fuel calculation put the remaining fuel quantity at about 79 tonnes, which tallied well with the totalizer fuel quantity figure. This gave the flightcrew members the confidence that the totalizer fuel quantity was accurate and they were not experiencing a fuel leak. They decided that the fuel disagree message was a spurious one and that, therefore, there was no need to conduct a fuel leak check.

During the initial training to operate this aircraft, the operator provides training to all its pilots to understand the requirements of the fuel disagree checklist. However, in this case, the flight crew appeared to have misinterpreted certain requirements of this checklist even though it has undergone the training.

As part of its recurrent training for pilots, operators may wish to consider including periodic refresher training on the requirements of the checklists that are used infrequently. This will increase the likelihood that checklists will be executed as intended.

## Conclusion

This occurrence brought several interesting issues into consideration. Other than having to determine the cause and propagation of the fire, other factors such as regulatory requirements, risk management processes, recurrent training for flight crews, and human performance were considered in this investigation.

In conclusion, the experience and lessons learned through this investigation will benefit stakeholders in the aviation industry as they continue to seek the optimal balance between ensuring safety, maintaining operating efficient, and profitability. ♦

## ISASI Kapustin Scholarship Essay

The following article is the final of four essays from the 2018 Kapustin scholarship winners. The number of scholars selected each year depends upon the amount of money ISASI members donate annually to the scholarship fund. Details about scholarship applications and additional information can be found on the ISASI website at [www.isasi.org](http://www.isasi.org). Application and essay deadlines are mid-April of each year—Editor.



Avery Katz  
2018 Kapustin scholarship recipient



Avery Katz presents his 2018 essay to the participants of ISASI 2018

# HOW AN EXTREME SPORT HIGHLIGHTS BROADER ISSUES FOR AIR SAFETY INVESTIGATORS: SKYDIVING OPERATIONS AND AIR SAFETY INVESTIGATION

By Avery Katz, Embry-Riddle Aeronautical University

It is no secret that in the United States, National Transportation Safety Board (NTSB) investigators often have their hands full. According to the Federal Aviation Administration (FAA), there were 513 accidents between the years of 2013 and 2016 that were investigated by the NTSB, which has about 400 employees (Fact Sheet 2014). Despite this workload, the NTSB still does a fantastic job.

As a licensed skydiver with more than 300 jumps, a former Cessna jump pilot, and president of the Aviation Safety Advisory Council at Embry-Riddle, I have always paid a great deal of attention to jump plane accidents and the subsequent NTSB reports. A website called Diver Driver has done a fantastic job of chronicling all aviation accidents since 1982.

Last year when reviewing these reports on the site, I noticed a trend. Since 2004, there have been approximately 21 fatal accidents directly related to jump plane operations (Jump Plane, 2018). What is alarming? Nearly 20 percent of the accidents share a common cause that has resulted in five fatalities. This is the result of, as the NTSB states, “inadvertent deployment of the reserve parachute.” (Rep. No. ERA09LA435)

A review of the evidence will show that despite a trend in probable cause across four accidents, there has been no change in verbiage within the FAR *AIM* or additional flight training requirements to help prevent future incidents. Unfortunately, this means similar accidents will likely occur in the future, thus increasing the workload of investigators who have already presented the evidence needed to decrease accident figures.

The following evidence will show a major disconnect between those who investigate accidents and those who make regulations based upon the findings. Thus, a significant challenge to air safety investigators is a lack of useful regulations originating from accident investigations.

## Accident review (in chronological order)

The first accident of the four, beginning in the 2004–2016 period studied, occurred on Oct. 24, 2004. The aircraft involved was a Cessna 206, tail number N8619Z (Rep. No. CHI05LA014). Generally, skydiving aircraft will climb to various altitudes depending upon aircraft type. For instance, PAC 750s generally climb to 13,500, Cessnas normally climb to 10,500, etc. In this case, the 206 climbed to the normal altitude of 10,500 feet.

The NTSB stated, “Aircraft control [was] not possible by the pilot following a premature deployment of a parachute as a parachutist exited the jump airplane during cruise flight. The inverted spin encountered by the pilot was an additional cause.” (Rep. No. CHI05LA014)

In this case, we see a simple inadvertent deployment by the jumper. With no further information listed, the likely cause was that the reserve handle was jumped on exit either by the jumper or by contact with the airframe.

The second accident occurred on April 19, 2008. The aircraft was again a Cessna 206, tail number N2537X (Rep. No. DEN08FA078). This was an interesting case in which multiple problems ultimately led to the fatal accident. While at altitude, the pilot entered a stall and spin when trying to

position for the jump run. This led to a rapid, uncontrolled descent during which multiple jumpers were able to bail out of the airplane.

However, sometime during the descent, witnesses claimed it appeared the airplane leveled out at “1,000 to 5,000 feet,” indicating that the pilot may have regained control. However, a passenger’s reserve parachute could then be seen “wrapped around the tail,” indicating an inadvertent deployment.

At this point, the aircraft again became uncontrolled and “spun or dove to the ground.” (Rep. No. DEN08FA078) The NTSB report stated, “Contributing factors in this accident were the entanglement of the parachute in the elevator control system, reducing the pilots ability to regain control.” (Rep. No. DEN08FA078) While the reserve deployment was not the first event in the sequence that led to this accident, it certainly didn’t make recovery any easier for the pilot. In fact, witness testimony suggests the pilot may have recovered but then entered a secondary spin upon reserve deployment.

The third accident occurred on Aug. 1, 2009. The aircraft type was a Beechcraft B90, tail number N1999G (Rep. No. ERA09LA435). The NTSB stated, “An instructor positioned himself at the door opening with his jump student nearby. The student inadvertently pulled the instructor’s reserve parachute D-ring, deploying the chute and pulling the instructor out of the airplane. The instructor contacted the left horizontal stabilizer then descended toward the ground coming to rest suspended in a tree by his parachute.” (Rep. No. ERA09LA435) While blame can certainly be placed on the competency of the student in this instance, it is also questionable that an instructor was using an easily catchable reserve D-handle when jumping with an inexperienced student.

The final accident occurred on Aug. 16, 2013. The aircraft type was a Cessna 206, and the registration was N2070K. The NTSB stated, “During the flight, [a] passenger moved forward in the cabin, which resulted in the passenger’s reserve parachute inadvertently deploying and the passenger being pulled through the open jump door. The passenger hit the doorframe, and the parachute became entangled with the empennage.... A post-accident examination revealed that the passenger had inadvertently attached his

seatbelt to the handle that released the reserve parachute. Therefore, the reserve parachute deployed when the passenger moved.” (Rep. No. CEN13LA500)

The NTSB noted the probable cause as “The improper routing of the seatbelt, which resulted in the inadvertent deployment of the reserve parachute, and the open jump door, which allowed the passenger to be pulled from the airplane.” (Rep. No. CEN13LA500) This probable cause is very telling. While it does not specifically list D-handles, the process of elimination can be used to figure out which type of handle was involved. Generally, there are D-handles and spongy, soft fabric handles. However, D-handles are the only type with a hold point, thus they are the only type that could have had a seatbelt threaded through them.

### The trend

Between the years of 2004 and 2016, the NTSB positively identified inadvertent reserve deployments as the cause of 19 percent of fatal aircraft accidents in the skydiving community. Upon closer examination, nearly 10 percent were directly related to the use of a D-handle. Curiously, a further statistic is that 75 percent of the fatal accidents involving inadvertent deployments were Cessna 206 crashes. These are proven statistics gained from numerous NTSB reports. Thus, the question that must be answered is: Has the FAA made any changes to federal regulations that would affect reserve container/handle construction, ban the use of D-handles, or change training standards for jump aircraft with higher fatality rates? The answer is no.

### Federal regulations

The section of the FAR *AIM* that deals with reserve parachutes is 14 CFR 105.43, “Use of single-harness, dual-parachute systems.” The following excerpt is taken from that section: “The main parachute must have been packed within 180 days before the date of its use by a certificated parachute rigger, the person making the next jump with that parachute, or a noncertificated person under the direct supervision of a certificated parachute rigger. (b)The reserve parachute must have been packed by a certificated parachute rigger....” (CFR 14, § 105.43 (2018))

In Part 105, this is the only mention of reserve parachutes in a sport container (excluding tandem rigs). The FAA

certainly provides clear guidance on reserve parachutes and how often they need to be repacked. It even goes into detail to discuss varied materials, canopy conditions, etc. Yet in the entirety of the FAR *AIM*, there is no mention of specific requirements for the construction of a reserve deployment handle, even though there is clearly a trend that certain designs lead to fatalities on board aircraft.

Furthermore, given the high percentage of Cessna 206s in accidents such as those examined, one must ask if the FAA has implemented any kind of special training for jump pilots in the aircraft. The answer is no. It has been proven that special federal regulations (SFAR) have been effective in the past. For instance, it reduced MU-2 accidents from 40 fatalities between 1988 and 2008 to only two between 2008 and 2016 (new MU-2B, 2016). Despite this, the FAA has not implemented any such training for Cessna 206s converted for jump operations.

### Conclusion and recommendation

The findings in recent aircraft accidents show a trend, yet the FAA has failed to input new regulations in response to the trends that have been displayed over a 12-year period of jump aircraft operation. Probable cause findings in four accidents have identified the reserve parachute as a factor, and at least two of them were further tied to a specific D-ring design. Furthermore, 75 percent of these accidents involved the same kind of aircraft, a Cessna 206.

Yet this is where the work of an investigator stops, and another organization such as the FAA must take charge. The organization must review the information provided and create meaningful change in regulations to save lives. In the example of skydiving operations used throughout this paper, meaningful change would include an addition to the verbiage in Part 105. Examples could include a ban of D-rings, which potentially serve as a snag hazard on exits and seatbelts and can inadvertently be deployed by inexperienced student jumpers. Furthermore, an SFAR could be implemented that would help future Cessna 206 jump pilots create a safer environment for skydivers. The most important fact is that this issue spans beyond skydiving. The aviation system in the United States could benefit

(Continued on page 30)

# NEWS ROUNDUP

## ESASI Holds 2019 Seminar at Rolls-Royce Center

The European Society of Air Safety Investigators (ESASI) workshop was run on three sessions:

- How can the investigation of design aspects be enhanced to improve safety throughout the lifecycle of an aircraft?
- How effective are safety recommendations and safety actions related to aircraft design?
- How can we further improve the relationship between investigators from safety investigation authorities, manufacturers, regulators and operators?

At the start of each session, there was an introductory statement followed by a number of presentations representing views from across the industry. Table discussions followed, and each session was concluded with an open discussion session. The main points were captured by the 14 table rapporteurs. Seating was preassigned to ensure that each table had a wide representation from across the aerospace industry.

The ESASI committee is reviewing the views of the workshop that will be used to produce a briefing paper that will be widely distributed. The 14 rapporteurs will be invited to review the draft paper. ♦

icana de Servicios de Navegación Aérea); and Dr. Leonidas Duarte (Instituto Nicaragüense de Aviación Civil). ♦



*A delegation of Nicaraguan aviation air safety and corporate officials meets in Buenos Aires, Argentina, with ISASI's Latin American Regional Society representatives.*



*Participants at the European Society of Air Safety Investigators workshop take time out for a photo at the Rolls-Royce Learning and Development Centre.*

## Latin America Regional Society Meets with Nicaraguan Delegation

Air safety and corporate officials from Nicaragua meet recently with officials from the Latin American Society of Air Safety Investigators (LARSASI) in Buenos Aires, Argentina, to discuss regional air safety issues and to join the ISASI regional society. Shown from the left are Ing. Guillermo Guido, director, ANIA (Asociación Nicaragüense de Investigación de Accidentes); Enriqueta Zambonini, LARSASI advisor; Capt. Carlos Salazar, DGAC Nicaragua/Pte. Griaa (Grupo Regional de Investigación Accidentes de Aviación Civil); Capt. Daniel Barafani, Pte. LARSASI; Dra. Eveling Arauz, advisor, COCESNA (Corporación Centroamer-

## SASI Pakistan Holds Reachout Sessions

The Pakistan Society of Air Safety Investigators hosted a series of courses, workshops, and presentations as the 54th ISASI Reachout in Karachi, Lahore, Kamra, and Islamabad, Pakistan, on June 10–25. The arrangements and coordination were made by Wing Commander (Ret.) Syed Naseem Ahmed, president of SASI Pakistan. Pakistan International Airlines (PIA) supported the courses by providing air transport for the two instructors from Toronto, Canada, to Karachi and return from Lahore. Capt. Mohsin Ausaf Khan, the PIA senior manager for safety, extended his full support, without which it wouldn't have been possible to conduct these Reachout events.

The one-week course (incident investigation and safety risk management) was conducted for PIA with some participants from the Pak Army Aviation, the Pak Navy, and the Pakistan Air Force at the PIA Training Centre in Karachi from June 10–14. The ISASI instructors were Mike Doiron, representing ISASI and Cirrus Aviation (Halifax, Nova Scotia, Canada), and ISASI International Councilor Caj Frostell.

The Pakistan Society coordination and arrangements were handled by Syed Naseem Ahmed and Mohsin Ausaf Khan. The SASI Pakistan officials took great care to ensure that the instructors and participants had everything they needed to maximize learning and course success. Instructors prepared master copies of their training material, and the Pakistan Society arranged for reproduction of the presentations in the form of a hardcopy participant handout.

*PIA Flight Safety Seminar*—On the afternoon of June 14, instructors and course participants were invited to attend the PIA Flight Safety Seminar at the PIA Training Centre auditorium. The seminar was organized by Mohsin Ausaf Khan and included several presentations on safety issues by PIA Safety Department experts, as well as presentations by ISASI instructors.



*Reachout participants at ATS Karachi on June 20. CAA Additional Director Safety Management and Quality Assurance Hasan Mujahid is in the center with ISASI instructors.*

**Karachi Institute of Economics & Technology**—On June 17, instructors gave half-day presentations to the aviation program students of the Pakistan Air Force Karachi Institute of Economics & Technology. The event was held at the PIA Training Centre auditorium.

**CAA Airworthiness Directorate**—On June 18–19, instructors were invited to the civil aviation authority (CAA) Pakistan Airworthiness Directorate to conduct a two-day workshop for invited operator representatives and airworthiness inspectors.

**Air Traffic Services in Karachi**—On June 20, the CAA Air Traffic Services Department invited instructors to conduct a workshop for senior air traffic controllers in Karachi. The event was held at the CAA ATS premises. In the evening, instructors flew from Karachi to Lahore.

**Air Traffic Services in Lahore**—On June 21, the CAA Air Traffic Services in Lahore invited instructors to conduct a workshop for senior air traffic controllers. The event was held at the CAA premises. Asad Gondal, the CAA's senior air traffic controller, was ISASI's contact and support person in Lahore. He arranged an interesting visitor tour of Lahore for the instructors. On June 22, instructors took a bus from Lahore to Islamabad.

**Pakistan Aeronautical Complex Kamra**—On June 24, instructors presented a half-day workshop at the Pakistan Aeronautical Complex (PAC) in Kamra. The PAC Kamra is an impressive aeronautical manufacturing facility that produced mostly military aircraft, glass cockpits, and aircraft instrumentation and has some 30,000 employees. The PAC Kamra hosts were Air Commodores Waqas Mahni and Asif Maqsood.

**SASI Pakistan International Safety Awareness Seminar**—In preparation for the SASI Pakistan International Safety Awareness Seminar titled "Future of Accident Investigations" on June 24, instructors participated in a press conference to promote the next day's seminar. The seminar was attended by 400 participants, SASI Pakistan members, safety experts representing aviation and road safety, and students from the Air University in Islamabad. The seminar was held in the auditorium of the Air University. The inauguration was delivered by the Vice Chief of Air Staff Air Marshal Asim Zaheer. The program included presentations from the two ISASI instructors and a number aviation and road safety specialists, including Squadron Leaders Mehmood Masood and Faisal Bashir Bhura.

The seminar was a major success for SASI Pakistan, Syed Naseem Ahmed, and SASI Pakistan members Mohsin Ausaf Khan, Major General (Ret.) Muhammad Azam (vice president of SASI Pakistan), Squadron Leader Athar Sajid, and Dr. Fatima Yousuf.

An evening social event was hosted by SASI Pakistan for its members and instructors at the Monal restaurant on a mountainside overlooking Islamabad.

On June 2, SASI Pakistan and the Pakistan Air Force invited instructors for a tour four hours northeast of Islamabad into the foothills of the Himalaya and visited a Pakistan Air Force base in Kalabagh, close to the border with India.

Numerous seminar participants noted that it was a unique opportunity arranged by SASI Pakistan in which the aviation industry (CAA, airlines, Air Force) came together with road safety authorities and road safety experts to discuss safety issues. From an ISASI instructor perspective, the multitude of ISASI Reachout activities was a unique opportunity to exchange experiences and discuss different ways of implementing safety strategies, handling emergency situations, carrying out investigations, implementing safety actions, and exchanging ideas. Instructors truly appreciated the excellent arrangements, the interactions with management and course/workshop participants, and the exceptional hospitality. ♦

## *In Memoriam*

**Robert Gould** died at home in Florence, Massachusetts, USA, on June 4 of cardiac arrest. Robert joined ISASI in 2013. The *Daily Hampshire Gazette* noted he was involved with aviation from an early age and traveled with his parents in the family plane to Alaska, throughout the western United States, and to the Bahamas. Robert worked at an aircraft engine facility and had a pilot license before he was old enough to obtain a driver's license.

After graduating from Kent State University and earning a master's degree at SUNY Empire State College in New York, Robert joined the U.S. Navy and served active duty at the Patuxent River Naval Air Station in Maryland. He then joined the Naval Air Systems Command as an active reservist where he retired at the rank of captain in 2002. He worked for business aviation maintenance companies for many years.

Beginning a teaching career, Robert retired to form his own consulting company. He taught aviation safety courses around the world and was an instructor for the University of Southern California Aviation and Security Program. Robert was an active volunteer for Wright Flight, an organization that introduces young people to aviation fields, and served on the boards of several aviation organizations. He received several awards during his careers, including the Charles Taylor Award from the U.S. Federal Aviation Administration for lifetime achievement in aviation maintenance. ♦

## ISASI Kapustin Scholarship Essay

(Continued from page 27)

in many instances from seeing more changes based upon the NTSB's findings. In this case, skydiving is simply indicative of a much larger issue. If this problem can be solved in jump plane operations, it would create a pattern of meaningful change throughout the aviation community. ♦

### References

CFR 14, § 105.43 (2018).

Fact Sheet—General Aviation Safety. (Sept. 19, 2014). Retrieved April 9, 2018, from [https://www.faa.gov/news/fact\\_sheets/news\\_story.cfm?newsId=21274](https://www.faa.gov/news/fact_sheets/news_story.cfm?newsId=21274).

Jump Plane Accidents by Year (U.S.). (n.d.). Retrieved April 6, 2018, from <http://diverdriver.com/accidents-by-year>.

New MU-2B training rules published. (Sept. 7, 2016). Retrieved April 9, 2018, from <https://www.aopa.org/news-and-media/all-news/2016/september/07/new-mu-2b-training-rules-published>.

<https://www.aopa.org/news-and-media/all-news/2016/september/07/new-mu-2b-training-rules-published>.

(Rep. No. CEN13LA500). (n.d.). Retrieved April 10, 2018, from [https://www.nts.gov/\\_layouts/nts.aviation/brief.aspx?ev\\_id=20130822X63331&key=1](https://www.nts.gov/_layouts/nts.aviation/brief.aspx?ev_id=20130822X63331&key=1).

(Rep. No. CHI05LA014). (n.d.). Retrieved April 10, 2018, from [https://www.nts.gov/\\_layouts/nts.aviation/brief.aspx?ev\\_id=20041028X01721&key=1](https://www.nts.gov/_layouts/nts.aviation/brief.aspx?ev_id=20041028X01721&key=1).

(Rep. No. DEN08FA078). (n.d.). Retrieved April 10, 2018, from [https://www.nts.gov/\\_layouts/nts.aviation/brief.aspx?ev\\_id=20080429X00561&key=1](https://www.nts.gov/_layouts/nts.aviation/brief.aspx?ev_id=20080429X00561&key=1).

(Rep. No. ERA09LA435). (n.d.). Retrieved April 10, 2018, from [https://www.nts.gov/\\_layouts/nts.aviation/brief.aspx?ev\\_id=20090803X05217&key=1](https://www.nts.gov/_layouts/nts.aviation/brief.aspx?ev_id=20090803X05217&key=1).

### OFFICERS

*President*, Frank Del Gandio  
(frankdelgandio@verizon.net)  
*Executive Advisor*, Richard Stone  
(rbstone2@msn.com)  
*Vice President*, Ron Schleede  
(ronschleede@aol.com)  
*Secretary*, Chad Balentine  
(chad.balentine@alpa.org)  
*Treasurer*, Robert MacIntosh, Jr.  
(trvlmac@verizon.net)

### COUNCILORS

*Australian*, Richard Sellers  
(richard.sellers@defence.gov.au)  
*Canadian*, Barbara Dunn (avsafe@shaw.ca)  
*European*, Rob Carter  
(robcarter@aol.com)  
*International*, Caj Frostell  
(cfrostell@sympatico.ca)  
*New Zealand*, Alister Buckingham  
(alister.buckingham@caa.govt.nz)  
*Pakistan*, Wg. Cdr. (Ret.) Naseem Syed  
Ahmed (naseem6408@hotmail.com)  
*United States*, Toby Carroll  
(toby.carroll@sbcglobal.net)

### NATIONAL AND REGIONAL SOCIETY PRESIDENTS

*AsiaSASI*, Chan Wing Keong  
(Chan\_wing\_keong@mot.gov.sg)  
*Australian*, Richard Sellers  
(richard.sellers@defence.gov.au)  
*Canadian*, Barbara Dunn (avsafe@shaw.ca)  
*European*, Olivier Ferrante  
(olivier.ferrante@esasi.eu)  
*Korean*, Dr. Tachwan Cho (contact: Dr. Jenny  
Yoo—dgyennyoo@naver.com)  
*Latin American*, Daniel Barafani, PTE  
(dbarafani@yahoo.com.ar)  
*Middle East North Africa*, Khalid Al Raisi  
(kalraisi@gcca.gov)  
*New Zealand*, Paul Breuille  
(pbhelix@hotmail.com)  
*Pakistan*, Wg. Cdr. (Ret.) Naseem Syed  
Ahmed (naseem6408@hotmail.com)  
*Russian*, Vsvolod E. Overharov  
(orap@mak.ru)  
*United States*, Toby Carroll  
(toby.carroll@sbcglobal.net)

### UNITED STATES REGIONAL CHAPTER PRESIDENTS

*Alaska*, Craig Bledsoe  
(kl4e@arrl.net)  
*Arizona*, Bill Waldock (wwaldock@msn.com)  
*Dallas-Ft. Worth*, Erin Carroll  
(erin.carroll@wnco.com)  
*Great Lakes*, Matthew Kenner  
(mtkenner@esi-il.com)  
*Mid-Atlantic*, Frank Hilldrup  
(fhilldrup@gmail.com)  
*Northeast*, Steve Demko  
(steve.demko@alpa.org)  
*Northern California*, Kevin Darcy  
(kevindarcy@gmail.com)  
*Pacific Northwest*, (Acting) John Purvis  
(jwpurvis@earthlink.net)  
*Rocky Mountain*, David Harper  
(4davidharper@gmail.com)

## MOVING? NEW E-MAIL ACCOUNT?

Do you have a new mailing address? Have you recently changed your e-mail address? Then contact ISASI at [isasi@erols.com](mailto:isasi@erols.com) to ensure that your magazine and other ISASI materials are delivered to you. Please include your previous address with your change request. Members in Canada, New Zealand, and Australia should contact your national society.

# ISASI INFORMATION

*Southeastern*, Robert Rendzio  
(rrendzio@srca.net)  
*Southern California*, Thomas Anthony  
(thomasa@usc.edu)

## COMMITTEE CHAIRMEN

*Audit*, Dr. Michael K. Hynes  
(hynesdrm@aviationonly.com)  
*Award*, Gale E. Braden (galebraden@gmail.com)  
*Ballot Certification*, Tom McCarthy  
(tomflyss@aol.com)  
*Board of Fellows*, Curt Lewis (curt@curt-lewis.com)  
*Bylaws*, Darren T. Gaines  
(darren.t.gaines@faa.gov)  
*Code of Ethics*, Jeff Edwards (vtailjeff@aol.com)  
*Membership*, Tom McCarthy (tomflyss@aol.com)  
*Mentoring Program*, Anthony Brickhouse  
(isasistudentmentoring@gmail.com)  
*Nominating*, Troy Jackson  
(troy.jackson@dot.gov)  
*Reachout*, Glenn Jones (glennwan\_nbn@inet.net.au)  
*Scholarship Committee*, Chad Balentine  
(chad.balentine@alpa.org)  
*Seminar*, Barbara Dunn (avsafe@shaw.ca)

## WORKING GROUP CHAIRMEN

*Air Traffic Services*, Scott Dunham (Chair)  
(dunhams@ntsb.gov)  
Ladislav Mika (Co-Chair) (ladi.mika@seznam.cz)  
*Airports*, David Gleave (spotwelder@hotmail.com)  
*Cabin Safety*, Joann E. Matley  
(jaymat02@aol.com)  
*Corporate Affairs*, Erin Carroll  
(erin.carroll@wnco.com)  
*Critical Incident Stress Management (CISM)*,  
David Rye–(Drye@aib.gov.sa)  
*Flight Recorder*, Michael R. Poole  
(mike.poole@planesciences.com)  
*General Aviation*, Steve Sparks  
(steven.sparks@faa.gov)  
Co-Chair, Doug Cavannah  
(Douglas.Cavannah@outlook.com)  
*Government Air Safety Facilitator*,  
Marcus Costa (mcosta@icao.int)  
*Human Factors*, Edma Naddof  
(edma@edmaexec.ae)  
*Investigators Training & Education*,  
Graham R. Braithwaite  
(g.r.braithwaite@cranfield.ac.uk)  
*Military Air Safety Investigator*, James W. Roberts  
(james.w.roberts3@boeing.com)  
*Unmanned Aerial Systems*, Tom Farrier  
(farrierT@earthlink.net)

## CORPORATE MEMBERS

AAIU, Ministry of Transport  
Abakan Air  
Accident Investigation Board (AIB) Army Aviation  
Accident Investigation Board Norway  
Accident Investigation Bureau Nigeria  
Administration des Enquêtes Techniques  
Adnan Zuhairy Engineering Consultancy  
Aegean Airlines  
Aer Lingus  
Aero Republica  
Aerovias De Mexico, S.A. De C.V.  
Agenzia Nazionale Per La Sicurezza Del Volo  
Air Accident Investigation Authority of Hong Kong  
Air Accident Investigation Bureau of Mongolia  
Air Accident Investigation Bureau of Singapore  
Accident Investigation Committee of Thailand  
Air Accident Investigation Unit-Ireland  
Air Accident Investigation Sector, GCAA, UAE  
Air Accidents Investigation Branch-UK  
Air Asia Group

Air Astana JSC  
Air Canada  
Air Canada Pilots Association  
Air Line Pilots Association  
Airbus  
Airclaims Limited  
Air New Zealand  
Airways New Zealand  
All Nippon Airways Co., Ltd. (ANA)  
Allianz  
Allied Pilots Association  
Aloft Aviation Consulting  
Aramco Associated Company  
Asiana Airlines  
Asociación Nicaragüense de Investigación de  
Accidentes  
ASPA de Mexico  
ASSET Aviation International Pty. Ltd.  
Association of Professional Flight Attendants  
Australian and International Pilots' Association  
(AIPA)  
Australian Transport Safety Bureau  
Aviation Investigation Bureau, Jeddah,  
Kingdom of Saudi Arabia  
Aviation Safety Council  
Avisure  
Azure Aero Ltd  
Becker Helicopters Pty. Ltd.  
Bell  
Bundesstelle fur Flugunfalluntersuchung (BFU)  
Bureau d'Enquêtes et d'Analyses (BEA)  
CAE Flightscape  
Cathay Pacific Airways Limited  
Centurion Aerospace Ltd.  
Charles Taylor Aviation  
China Airlines  
Civil Aviation Authority, Macao, China  
Civil Aviation Department Headquarters  
Civil Aviation Safety Authority Australia  
Civil Aviation Safety Investigation and Analysis  
Center  
Colegio Oficial de Pilotos de la Aviación  
Comercial (COPAC)  
Commercial Aircraft Corporation of China  
Cranfield Safety & Accident Investigation  
Centre  
Curt Lewis & Associates, LLC  
Dassault Aviation  
DDAAFS  
Defence Science and Technology Organisation  
(DSTO)  
Defense Conseil International (DCI/IFSA)  
Delft University of Technology  
Delta Air Lines, Inc.  
Directorate of Flight Safety (Canadian Forces)  
Discovery Aur Defence  
Dombroff Gilmore Jaques & French P.C.  
DRS C3 & Aviation Company, Avionics Line of  
Business  
Dubai Air Wing  
Dubai Civil Aviation Authority  
Dutch Airline Pilots Association  
Dutch Safety Board  
Eclipse Group, Inc.  
Education and Training Center for Aviation  
Safety  
EL AL Israel Airlines  
Embraer-Empresa Brasileira de Aeronautica  
S.A.  
Embry-Riddle Aeronautical University  
Etihad Airways  
European Aviation Safety Agency (EASA)  
EVA Airways Corporation  
Executive Development & Management Advisor  
Finnair Plc  
Finnish Military Aviation Authority  
Flight Data Services Ltd.  
Flight Data Systems Pty. Ltd.  
Flight Safety Foundation  
Fugro Survey Middle East Ltd.  
Gangseo-gu, Republic of Korea  
GE Aviation  
General Aviation Manufacturers Association  
German Military Aviation Authority, Directorate of  
Aviation Safety Federal Armed Forces

Global Aerospace, Inc.  
Grup Air Med S.A.  
Grupo Regional de Investigación de Accidentes de  
Aviación  
Gulfstream Aerospace Corporation  
Hall & Associates LLC  
Hawaiian Airlines  
HNZ New Zealand Limited  
Hogreen Air  
Honeywell Aerospace  
Hong Kong Airline Pilots Association  
Human Factors Training Solutions Pty. Ltd  
Independent Pilots Association  
Insitu, Inc.  
Interstate Aviation Committee  
Irish Air Corps  
Irish Aviation Authority  
Japan Transport Safety Board  
Jones Day  
KLM Royal Dutch Airlines  
Korean Air  
Korea Aviation & Railway Accident  
Investigation Board  
L-3 Aviation Recorders  
Learjet/Bombardier Aerospace  
Lion Mentari Airlines, PT  
Lockheed Martin Aeronautics Company  
Middle East Airlines  
Midwest University  
Military Air Accident Investigation Branch  
Military Aircraft Accident & Incident  
Investigation Board  
Ministry of Transport, Transport Safety  
Investigation Bureau, Singapore  
National Aerospace Laboratory, NLR  
National Institute of Aviation Safety and  
Services  
National Transportation Safety Board  
National Transportation Safety Committee-  
Indonesia (KNKT)  
NAV CANADA  
Ocean Infinity  
Pakistan Air Force-Institute of Air Safety  
Pakistan Airline Pilots' Association (PALPA)  
Pakistan International Airlines Corporation (PIA)  
Papua New Guinea Accident Investigation  
Commission (PNG AIC)  
Parker Aerospace  
Petroleum Air Services  
Phoenix International Inc.  
Plane Sciences, Inc., Ottawa, Canada  
Pratt & Whitney  
PT Merpati Nusantara Airlines  
Qatar Airways  
Republic of Singapore Air Force (RSAF)  
Rolls-Royce PLC  
Royal Danish Air Force, Tactical Air Command  
Royal Netherlands Air Force  
Royal New Zealand Air Force  
RTI Group, LLC  
Saudia Airlines-Safety  
Scandinavian Airlines System  
Sikorsky Aircraft Corporation  
Singapore Airlines Limited  
Southern California Safety Institute  
Southwest Airlines Company  
Southwest Airlines Pilots' Association  
Spanish Airline Pilots' Association (SEPLA)  
State of Israel  
Statens haverikommisjon  
Swiss Accident Investigation Board (SAIB)  
The Air Group  
The Boeing Company  
The Japanese Aviation Insurance Pool (JAIP)  
Transportation Safety Board of Canada  
TurboMech  
Ukrainian National Bureau of Air Accidents and  
Incidents of Civil Aircraft  
UND Aerospace  
United Airlines  
United States Aircraft Insurance Group  
University of Balamand/Balamand Institute of  
Aeronautics  
University of Southern California  
Virgin Galactic  
WestJet ♦



ISASI

107 E. Holly Ave., Suite 11  
Sterling, VA 20164-5405 USA

CHANGE SERVICE REQUESTED

NON-PROFIT  
ORG.  
U.S. POSTAGE  
PAID  
Permit #273  
ANNAPOLIS,  
MD

## ANZSASI Holds Annual Regional Seminar

**N**ew Zealand Councillor Alister Buckingham reports that the 2019 Australian/New Zealand Society of Air Safety Investigators (ANZSASI) regional seminar was held in Wellington, New Zealand, June 7–9. Some 93 delegates participated. The event teed off on Friday with the inaugural Trans-Tasman golf challenge, with both sides fielding some big hitters and a mixed bag of others with varying degrees of skill. The Kiwis carried the day and secured the trophy.

Also on that Friday the New Zealand civil aviation authority (CAA) hosted an Asia-Pacific Cabin Safety Working Group meeting, and a record 67 delegates attended. Presentations ranged from lessons learned from incidents, reporting culture, dangerous goods, and aviation security to sexual assault on board aircraft and the airline response. Topical issues were also discussed, including hand luggage, fatigue, and passenger comfort devices. A highlight of the meeting was a presentation by Michael Burdick, a U.S. Federal Aviation Administration dangerous goods specialist, who provided an update



*Attendees of the Asia-Pacific Cabin Safety Working Group meeting, which was hosted by the New Zealand civil aviation authority.*

on the hazards associated with lithium batteries.

To round off the day's activity, 97 guests attended the ANZSASI welcome reception at the conference hotel, where there was no shortage of food and drink. This event was hosted entirely by NZSASI, with the cost having been factored into the seminar budget. The reception had its own highlight—no speeches!

Despite the hectic start to the weekend, the seminar was anything but an anticlimax. First up was Björn Hennig, who traveled from Germany especially for the seminar, his second such appearance. Hennig delivered the Ron Chippindale Memorial Presentation; his theme was data-driven fatigue management. Burdick made a reprise appearance, this time with a safety management system theme, and the seminar continued

through the weekend with a total of 20 first-class technical papers plus a summary of the cabin safety proceedings. Most papers are now available on the ASASI website.

Both societies conducted their business meetings immediately after the Saturday program. The NZSASI agenda included the confirmation of the nominations for the Society's Executive. Paul Breuilly was confirmed as the new president, Louise (Lou) Child as vice president, and Alister Buckingham reconfirmed as councillor. These were the only nominations received, as there was none for secretary/treasurer up to this point. An appeal was made to the membership for someone to step up and relieve Russell Kennedy after his 20-odd years of sterling service in the role. Early the next morning, Michael Eastwood volunteered his services. The

business meeting was reconvened briefly at the end of the Sunday morning session to confirm (very gratefully) Eastwood's appointment. Other agenda items confirmed that the Society was in good physical and financial health, with the membership steady around the 70 mark, and that there were sufficient funds in hand to cover a total loss on a regional seminar if that extreme circumstance were ever to arise. This year's seminar was again budgeted to incur a small loss, in keeping with the Society's not-for-profit status.

The ritual president-to-president handover of the seminar cowbell to ASASI was the final act of the weekend, after Rick Sellers had announced the venue and dates for the 2020 events. ♦