

*Publisher*

ISASI (Frank Del Gandio, President)

*Editorial Advisor*

Richard B. Stone

*Editorial Staff*

Susan Fager

Esperison Martinez

*Design*

William A. Ford

**ISASI Proceedings** (ISSN 1562-8914) is published annually by the International Society of Air Safety Investigators. Opinions expressed by authors are not necessarily endorsed or represent official ISASI position or policy.

**Editorial Offices:** 107 E. Holly Ave., Suite 11, Sterling, VA 20164-5405 USA. Telephone: (703) 430-9668. Fax: (703) 450-1745. E-mail address: [isasi@erols.com](mailto:isasi@erols.com). Internet website: <http://www.isasi.org>.

**Notice:** The *Proceedings* of the ISASI 39th annual international seminar held in Halifax, Nova Scotia, Canada, features presentations on safety issues of interest to the aviation community. The papers are presented herein in the original editorial content supplied by the authors.

**Copyright © 2009**—International Society of Air Safety Investigators, all rights reserved. Publication in any form is prohibited without permission. Permission to reprint is available upon application to the editorial offices.

**Publisher's Editorial Profile:** *ISASI Proceedings* is printed in the United States and published for professional air safety investigators who are members of the International Society of Air Safety Investigators. Content emphasizes accident investigation findings, investigative techniques and experiences, and industry accident-prevention developments in concert with the seminar theme "Investigation: The Art and the Science."

**Subscriptions:** Active members in good standing and corporate members may acquire, on a no-fee basis, a copy of these *Proceedings* by downloading the material from the appropriate section of the ISASI website at [www.isasi.org](http://www.isasi.org). Further, active and corporate members may purchase the *Proceedings* on a CD-ROM for the nominal fee of \$15, which covers postage and handling. Non-ISASI members may acquire the CD-ROM for a \$75 fee. A limited number of paper copies of past *Proceedings* and *Proceedings 2008* is available at a cost of \$150. Checks should accompany the request and be made payable to ISASI. Mail to ISASI, 107 E. Holly Ave., Suite 11, Sterling, VA 20164-5405 USA

ISSN 1562-8914



*Air Safety Through Investigation*

# Proceedings of the 39th Annual International Seminar

## 'Investigation: The Art and the Science'

Sept. 8–11, 2008

Halifax, Nova Scotia, Canada



# ISASI Information

## OFFICERS

*President*, Frank Del Gandio (frank.delgandio@faa.gov)  
*Executive Advisor*, Richard Stone (rbstone2@msn.com)  
*Vice-President*, Ron Schleede (ronschleede@aol.com)  
*Secretary*, Chris Baum (chris.baum@alpa.org)  
*Treasurer*, Tom McCarthy (tomflyss@aol.com)

## COUNCILLORS

*Australian*, Lindsay Naylor (lnaylor@spitfire.com.au)  
*Canadian*, Barbara Dunn (avsafe@uniserve.com)  
*European*, Anne Evans (aevans@aaib.gov.uk)  
*International*, Caj Frostell (cfrostell@sympatico.ca)  
*New Zealand*, Peter Williams (pgwilliams@clear.net.nz)  
*United States*, Curt Lewis (curt@curt-lewis.com)

## NATIONAL AND REGIONAL

### SOCIETY PRESIDENTS

*Australian*, Lindsay Naylor (lnaylor@spitfire.com.au)  
*Canadian*, Barbara M. Dunn (avsafe@rogers.com)  
*European*, David King (dking@aaib.gov.uk)  
*Latin American*, Guillermo J. Palacia (Mexico)  
*New Zealand*, Peter Williams (pgwilliams@clear.net.nz)  
*Russian*, Vsvolod E. Overharov (orap@mak.ru)  
*SESA-France Chapter*, Vincent Fave  
 (vincent.fave@aviation-experts.com)  
*United States*, Curt Lewis (curt@curt-lewis.com)

## UNITED STATES REGIONAL CHAPTER PRESIDENTS

*Alaska*, Craig Bledsoe  
 (craig\_bledsoe@ak-prepared.com)  
*Arizona*, Bill Wallock (wwallock@msn.com)  
*Dallas-Ft. Worth*, Tim Logan (timlogan@wnco.com)  
*Great Lakes*, Matthew Kenner (mkenner@esi-il.com)  
*Los Angeles*, Inactive  
*Mid-Atlantic*, Ron Schleede (ronschleede@aol.com)  
*Northeast*, David W. Graham (dwg@shore.net)  
*Pacific Northwest*, Kevin Darcy (kdarcy@safeserve.com)  
*Rocky Mountain*, David Harper  
 (david.harper@kirkland.af.mil)  
*San Francisco*, Peter Axehrod  
 (p\_axehrod@compuserve.com)  
*Southeastern*, Robert Rendzio (srca@snowhill.com)

## COMMITTEE CHAIRMEN

*Audit*, Dr. Michael K. Hynes  
 (hynesdrm@aviationonly.com)  
*Award*, Gale E. Braden (galebraden@cox.net)  
*Ballot Certification*, Tom McCarthy (tomflyss@aol.com)  
*Board of Fellows*, Ludi Benner (luben@patriot.net)  
*Bylaws*, Darren T. Gaines (dgaines@natca.org)  
*Code of Ethics*, Jeff Edwards (vtailjeff@aol.com)  
*Membership*, Tom McCarthy (tomflyss@aol.com)  
*Nominating*, Jayme E. Nichols (nichod97@erau.edu)  
*Reachout*, John Guselli (jguselli@bigpond.net.au)  
*Seminar*, Barbara Dunn (avsafe@uniserve.com)

## WORKING GROUP CHAIRMEN

*Air Traffic Services*, John A. Guselli (Chair)  
 (jguselli@bigpond.net.au)  
*Ladislav Mika (Co-Chair)* (mika@mdcr.cz)  
*Cabin Safety*, Joann E. Matley (jaymat02@aol.com)  
*Corporate Affairs*, John W. Purvis (jpurvis@safeserv.com)  
*Flight Recorder*, Michael R. Poole  
 (mike.poole@flightscape.com)  
*General Aviation*, William (Buck) Welch  
 (wwelch@cessna.textron.com)  
*Government Air Safety*, Willaim L. McNease  
 (billsing97@aol.com)  
*Human Factors*, Richard Stone (rstone2@msn.com)

### Investigators Training & Education,

Graham R. Braithwaite  
 (g.r.braithwaite@cranfield.ac.uk)  
*Unmanned Aerial Systems*, Tom Farrier  
 (Thomas.farrier@anser.org)

## CORPORATE MEMBERS

AAIU Ministry of Transport Bulgaria  
 Accident Investigation Board, Finland  
 Accident Investigation Board/Norway  
 Accident Investigation & Prevention Bureau  
 Aeronautical & Maritime Research Laboratory  
 AeroVeritas Aviation Safety Consulting, Ltd.  
 Aerovias De Mexico, S.A.De C.V.  
 Air Accident Investigation Bureau of Singapore  
 Air Accident Investigation Unit—Ireland  
 Air Accidents Investigation Branch—U.K.  
 Air Canada Pilots Association  
 Air Line Pilots Association  
 Air New Zealand, Ltd.  
 Airbus S.A.S.  
 Airclaims Limited  
 Aircraft Accident Investigation Bureau—Switzerland  
 Aircraft Mechanics Fraternal Association  
 Aircraft & Railway Accident Investigation Commission  
 Aircservices Australia  
 Air Tran Airways  
 Alaska Airlines  
 Alitalia Airlines—Flight Safety Dept.  
 All Nippon Airways Company Limited  
 Allied Pilots Association  
 American Eagle Airlines  
 American Underwater Search & Survey, Ltd.  
 AmSafe Aviation  
 Aramco Associated Company  
 ASPA de Mexico  
 Association of Professional Flight Attendants  
 Atlantic Southeast Airlines—Delta Connection  
 Australian Transport Safety Bureau  
 Aviation Safety Council  
 Avions de Transport Regional (ATR)  
 BEA-Bureau D'Enquetes et D'Analyses  
 Board of Accident Investigation—Sweden  
 Boeing Commercial Airplanes  
 Bombardier Aerospace Regional Aircraft  
 Bundesstelle fur Flugunfalluntersuchung—BFU  
 Cathay Pacific Airways Limited  
 Cavok Group, Inc.  
 Centurion, Inc.  
 Charles Taylor Aviation, Singapore  
 China Airlines  
 Cirrus Design  
 Civil Aviation Safety Authority Australia  
 Colegio De Pilotos Aviadores De Mexico, A.C.  
 Comair, Inc.  
 Continental Airlines  
 Continental Express  
 COPAC/Colegio Oficial de Pilotos de la Aviacion Comercial  
 Cranfield Safety & Accident Investigation Centre  
 Curt Lewis & Associates, LLC  
 DCI/Branch AIRCO  
 Defence Science and Technology Organization (DSTO)  
 Delta Air Lines, Inc.  
 Directorate of Aircraft Accident Investigations—Namibia  
 Directorate of Flight Safety (Canadian Forces)  
 Directorate of Flying Safety—ADF  
 Dombroff Gilmore Jaques & French P.C.  
 Dutch Airline Pilots Association  
 Dutch Transport Safety Board  
 EL AL Israel Airlines  
 Embraer-Empresa Brasileira de Aeronautica S.A.  
 Embry-Riddle Aeronautical University  
 Emirates Airline  
 Era Aviation, Inc.  
 European Aviation Safety Agency  
 EVA Airways Corporation  
 Exponent, Inc.  
 Federal Aviation Administration  
 Finnair Oyj

Finnish Military Aviation Authority  
 Flight Attendant Training Institute at Melville College  
 Flight Safety Foundation  
 Flight Safety Foundation—Taiwan  
 Flightscape, Inc.  
 Galaxy Scientific Corporation  
 General Aviation Manufacturers Association  
 GE Transportation/Aircraft Engines  
 Global Aerospace, Inc.  
 Gulf Flight Safety Committee, Azaiba, Oman  
 Hall & Associates, LLC  
 Hellenic Air Accident Investigation  
 & Aviation Safety Board  
 Honeywell  
 Hong Kong Airline Pilots Association  
 Hong Kong Civil Aviation Department  
 IFALPA  
 Independent Pilots Association  
 Int'l Assoc. of Mach. & Aerospace Workers  
 Interstate Aviation Committee  
 Irish Air Corps  
 Irish Aviation Authority  
 Japan Airlines Domestic Co., LTD  
 Japanese Aviation Insurance Pool  
 Jeppesen  
 JetBlue Airways  
 Jones Day  
 KLM Royal Dutch Airlines  
 Korea Air Force Safety Ctr.  
 Korea Aviation & Railway Accident Investigation Board  
 Kreindler & Kreindler, LLP  
 L-3 Communications Aviation Recorders  
 Learjet, Inc.  
 Lockheed Martin Corporation  
 Lufthansa German Airlines  
 MyTravel Airways  
 National Aerospace Laboratory, NLR  
 National Air Traffic Controllers Assn.  
 National Business Aviation Association  
 National Transportation Safety Board  
 NAV Canada  
 Nigerian Ministry of Aviation and Accident  
 Investigation Bureau  
 Northwest Airlines  
 Parker Aerospace  
 Phoenix International, Inc.  
 Pratt & Whitney  
 Qantas Airways Limited  
 Qatar Airways  
 Qwila Air (Pty), Ltd.  
 Raytheon Company  
 Republic of Singapore Air Force  
 Rolls-Royce, PLC  
 Royal Netherlands Air Force  
 Royal New Zealand Air Force  
 RTI Group, LLC  
 Sandia National Laboratories  
 SAS Braathens  
 Saudi Arabian Airlines  
 SICOFAA/SPS  
 Sikorsky Aircraft Corporation  
 Skyservice Airlines, Ltd.  
 Singapore Airlines, Ltd.  
 Delta Air Lines  
 SNECMA Motors  
 South African Airways  
 South African Civil Aviation Authority  
 Southern California Safety Institute  
 Southwest Airlines Company  
 Southwest Airlines Pilots' Association  
 Star Navigation Systems Group, Ltd.  
 State of Israel  
 Transport Canada  
 Transportation Safety Board of Canada  
 U.K. Civil Aviation Authority  
 UND Aerospace  
 University of NSW Aviation  
 University of Southern California  
 Volvo Aero Corporation  
 WestJet ♦

# Table of Contents

- 2 ISASI Information**
- 4 Preface: Welcome to Metro Halifax and to ISASI 2008**  
*By Frank Del Gandio, President, ISASI*
- 6 Keynote Address: Advancing Aviation Safety One Investigation at a Time**  
*By Wendy Tadros, Chair, Transportation Safety Board of Canada*
- 9 Lederer Award Recipient: C. Donald Bateman Receives Lederer Award**  
*By Esperison Martinez, Editor*
- 11 Silver Dart Salute**  
*By John A.D. McCurdy aka Capt. Gerry Davis*
- TUESDAY, SEPTEMBER 9**
- 13 DHC-6 Twin Otter Accident off the Coast of Moorea, French Polynesia**  
*By Alain Bouillard, Investigator-in-Charge, Special Advisor to the BEA, and Arnaud Desjardin, Safety Investigator, Engineering Department, BEA*
- 17 SR 111—Why Did They Die? Why Do We Refuse To Learn? The Swissair MD-11 ‘Modi-Plus’ Program in Today’s SFF Environment**  
*By Capt. Timothy Crowch, Advanced System Safety Management, Switzerland*
- 21 Causation: What Is It and Does It Really Matter?**  
*By Michael B. Walker (MO4093), Senior Transport Safety Investigator, Australian Transport Safety Bureau*
- 26 Approaches to Accident Investigation by Investigators from Different Cultures**  
*By Wen-Chin Li, Hong-Tsu Young, Thomas Wang, and Don Harris*
- 32 International Support for Aircraft Accident Investigation and Proposal to Enhance Aviation Safety in States Where It Is in Developing Stage**  
*By Syed Naseem Ahmed, Technical Investigator, Safety Investigation Board, Civil Aviation Authority, Pakistan*
- 37 What Can We Learn?**  
*By Graham Braithwaite (MO3644), Cranfield Safety and Accident Investigation Centre, Cranfield University, United Kingdom*
- 41 Accident Investigation—A Complete Service?**  
*By Phil Taylor, Senior Inspector of Air Accidents (Operations), UK AAIIB*
- WEDNESDAY, SEPTEMBER 10**
- 46 Managing the Complexities of a Major Aviation Accident Investigation**  
*By Joseph M. Kolly, Bruce G. Cowry, Vernon S. Ellingstad, and Aaron S. Dietz, National Transportation Safety Board, Washington, D.C., USA*
- 53 Weather Risk Management Through a Systematic Approach to the Investigation of Weather Events**  
*By John W. Dutcher, Dutcher Safety & Meteorology Services, and G. Mike Doiron, Cirrus Aviation Safety Services (M04646)*
- 62 An Attempt at Applying HFACS to Major Aircraft And Railway Accidents During the Period From 2001 to 2006 in Japan and Some Problems Analyzing Results**  
*By Yukiko Kakimoto, Ph.D., NPO, Aviation and Railways Safety Promotion, Tokyo, Japan*
- 67 Conversations in the Cockpit: Pilot Error or a Failure to Communicate?**  
*By Noelle Brunelle, H-53/S-61 Product Safety Lead, Sikorsky Aircraft Corporation, Stratford, Conn., USA*
- 71 Cockpit Information Recorder for Helicopter Safety**  
*By Roy G. Fox (M03514), Chief, Flight Safety, Bell Helicopter Textron Inc., Fort Worth, Tex., USA*
- 80 Use of Model Helicopter and Precise Differential GPS on the Occurrence Site Survey**  
*By Wen-Lin, Guan; Ming-Hao, Young; Tien-Fu, Yeh; and Hong T. Young, Aviation Safety Council (ASC), Taiwan, ROC*
- 87 Gas Turbines and Ice—The Mysterious Culprit**  
*By Al Weaver (MO4465), Senior Fellow Emeritus, Pratt & Whitney, USA*
- 92 Turbine Engine Risk Management In the U.S. Air Force**  
*By Richard Greenwood, Flight Safety Investigator, Pratt & Whitney, USA*
- THURSDAY, SEPTEMBER 11**
- 97 A Review of Rapid Changes in General Aviation and Their Likely Effect on GA Safety in Four Countries**  
*By Robert Matthews, Ph.D., Office of Accident Investigation, Federal Aviation Administration, USA*
- 103 Bringing the Worldwide Helicopter Accident Rate Down by 80%**  
*By Jack Drake, Helicopter Association International, USA*
- 108 SMS as an Investigation Tool**  
*By Capt. John Gadzinski, Director of Safety, Southwest Airlines Pilots Association*
- 111 Investigating Unmanned Aircraft System Accidents**  
*By Thomas A. Farrier (MO3763), Senior Analyst, Aerospace Safety and Operations Analytic Services, Inc., Arlington, Va., USA*
- 120 Occupant Protection—A Case Study Bombardier Challenger CL-600, Teterboro, N.J., Feb. 2, 2005**  
*By Nora C. Marshall (MO3036), Chief, Survival Factors Division, Office of Aviation Safety, National Transportation Safety Board (Presented by Frank Hilldrup)*
- 123 Problems in Operating Emergency Evacuation Slides: Analysis of Accidents and Incidents with Passenger Aircraft**  
*By Gerard van Es, Senior Consultant, NLR-Air Transport Safety Institute, Amsterdam, the Netherlands (Presented by Rombout Weaver)*
- 128 ISASI 2008 Pictorial Review**  
*By Esperison Martinez, Editor*

# PREFACE

## Welcome to Metro Halifax and To ISASI 2008

By Frank Del Gandio, President

**G**ood morning, everyone.

Welcome to metro Halifax and to ISASI 2008.

I will start by thanking our hosts, the Canadian Society of Air Safety Investigators. I especially wish to thank the president of the Canadian Society, Barbara Dunn. Barbara has organized more annual seminars for ISASI than any other member and, once again, I thank her for all her hard work.

Special thanks also to Jim Stewart and Nick Stoss for organizing the technical program, to Gail Stewart for organizing the companions' program, and to everyone who helped to organize yesterday's tutorials. Lots of other people deserve thanks as well, but I will ask their forgiveness if I simply move onto the seminar.

Our theme is "Investigation: The Art and the Science." Most people would agree that the science of accident investigation is better than ever, and it likely will get progressively better in the future. For starters, if all else fails, we still have the most

basic of scientific methods, observation. A great American philosopher, Yogi Berra, once noted correctly that we can observe a lot by just watching. But "all else" rarely fails, at least not in the air carrier world.

Today we routinely apply precise data from digital flight data recorders, quick access recorders, GPS and radar overlays, onboard voice recorders, FADECs, and so on. Even the once-humble GA aircraft may offer some onboard data, GPS data, or FADEC and trend monitors. Presentations throughout the seminar will address issues like these. Some papers also will address areas in which accident investigation needs to improve its scientific base, including differences between metal and composites when we examine failure modes or fire damage.

Given all the science available to us today, does art really continue to play a role? The short answer is, "yes." Accident investigation continues to be a mix of art and science. Just ask anyone who visually scans an accident site or anyone who converts the digital



E. MARTINEZ



data to an animated simulation; we know fairly precisely what the various parameters are, but we do not necessarily know what the airplane was really doing, or what was happening during the fractions of seconds between recordings. Better yet, ask anyone who has ever had to manage a major accident investigation, particularly one involving several national cultures, or ask someone who analyzes multiple accidents to help to inform safety policy. You will hear several presentations that add more substance to these ideas.

At each of our annual seminars, I briefly review the major accidents of the preceding year in order to remind us that the aviation safety community still has work to do. Though we indeed had some major accidents in the 12 months since we met in Singapore, the past year, in fact, has been a good year for aviation safety. By my count, we had 12 fatal accidents, and 8 major fatal passenger accidents. Once again, carriers from Africa and Central Asia accounted for a disproportionate share of those accidents, but the good news is that we had just one major accident in air carrier passenger operations in the 30 Organization for Economic Cooperation and Development (OECD) countries, plus China and India. Those 32 countries account for about 90 percent of all air carrier operations in the world, and they had just one major fatal accident in the past 12 months.

In fact, one of the most significant accidents of the past year in those 32 countries was the non-fatal B-777 accident at Heathrow. When I first heard that both engines had lost partial power at essentially the same time after a long flight from Beijing to London, I thought to myself, Let me guess, they were running out of fuel." Well, it turned out to be much more complex and more instructive than I first guessed. The B-777 investigation is a good example of the marriage between art and science, and of the international character of aviation accident investigation. The aircraft took off from China, flew a third of the way around the world, and crashed in the air carrier's home country in an aircraft that was certified in a third country.

In short, our profession will always remain at the front line of accident prevention, whether we investigate well-understood accident scenarios or new and complex scenarios.

Before I close, I want to make a few comments about our hosts. Ten years ago last Tuesday, 229 people died just a few miles from here, near Peggys Cove, in the Swissair accident. That complex accident investigation taught us several important things about aviation safety, but it also demonstrated several important things about Canada, about metro Halifax, and about the Maritime Provinces in general.

First, it reminded us about the skill and professionalism of the Transportation Safety Board of Canada in a very complex investigation. Accident investigators from the U.S. see this regularly, because each year several U.S. GA operators have accidents in Canada, while several Canadian GA aircraft have accidents in the U.S. I personally have worked some of those cases and I can tell you sincerely that all Canadians should be proud of the TSB; it is a world-class organization.

The Swissair accident also taught us something about the people of Peggys Cove and of Nova Scotia. The accident occurred at 9:30 at night. Yet, in the darkness, scores of local fishermen and other boat owners, one by one, voluntarily accepted real risk to them-

## **I urge everyone, but especially any students or young aviation professionals who have joined us here today, to take advantage of the wealth of knowledge and experience that is in this room.**

selves and set out to rescue any survivors. The accident, of course, was non-survivable, but that does not diminish the heroism that many local people demonstrated that night.

Air safety investigators also learned that the people of Peggys Cove would remain hospitable throughout the long investigation. If you talk to any ISASI members who were on site here, you will hear words like "decency" and "kindness" to describe the local people throughout that long effort.

Finally, I want to acknowledge the anniversary this week of another aviation tragedy, Sept. 11, 2001. In addition to the trauma associated with those events, we Americans were again reminded of the skill and the generosity of the Canadian people, particularly the people of eastern Canada.

When the U.S. closed its airspace that day, 39 aircraft and 6,000 to 7,000 passengers and crew were diverted to Gander in Newfoundland. Nearly as many were diverted to Halifax International Airport. In both communities, the local people showed incredible generosity.

The story in Gander was especially impressive. A community with perhaps 2,500 homes had to figure out—and quickly—what to do with 7,000 unexpected guests. Their answer was wonderfully simple: local people opened their homes to shelter, feed and even entertain all 7,000 people for several days, and at no small expense to residents. The hospitality was impressive in Halifax, as well. But, after what we saw at Peggys Cove several years earlier, we really should not have been surprised. Once again, words like decency and kindness come to mind.

Canada, of course, is one of many countries whose population has been built with people from around the world. Many of those ancestors entered Canada through Pier 21, just down the street here. As Americans understand very well, particularly those of us who are in aviation, those Canadian ancestors gave birth to a strong, competent, and generous country. While you are here, I hope you will find the time to explore this part of Canada, including the city and the many beautiful seaside villages like Peggys Cove.

Finally, before I close, I will remind everyone that whatever your particular interest may be in aviation safety or accident investigation, one or more people in this room will know all there is to know about the topic. I urge everyone, but especially any students or young aviation professionals who have joined us here today, to take advantage of the wealth of knowledge and experience that is in this room. I also urge everyone to participate actively in the seminar and to share your considerable expertise with anyone who seeks it out.

Enjoy the seminar and enjoy metro Halifax. Thank you. ♦

## KEYNOTE ADDRESS

# Advancing Aviation Safety One Investigation at a Time

By Wendy Tadros, Chair, Transportation Safety Board of Canada

*(Remarks presented by Chair Tadros in her keynote address to the ISASI 2008 air accident investigation seminar delegates on Sept. 9, 2008, in Halifax, Nova Scotia, Canada.—Editor)*

As chair of the Transportation Safety Board of Canada, it is a pleasure for me to speak to the world's leading safety investigators. In my 12 years at the TSB, I have come to admire the work you do. I am impressed by both your dedication and your attention to detail. Today, we have an opportunity to share our ideas and experiences. It is also a great opportunity to discuss the latest investigative techniques and to foster the strong working relationships that are absolutely essential to advancing transportation safety.

This year's ISASI theme is "Investigation: The Art and the Science." I want to talk to you about the science behind some key TSB investigations and the contribution they have made to aviation safety worldwide. In particular, I want to talk to you about our Morningstar and Air Transat investigations, which have resulted in positive change—thanks to solid investigative work and prompt action by regulators and industry in Canada and abroad.

I also want to practice the gentle art of persuasion and talk in more detail about MK Airlines, Air France, and Swissair. These are three investigations where we would like to see greater uptake of our recommendations. With your support, together we could make air travel even safer.

I want to start by telling you about some very positive international efforts on two fronts: firstly with Cessna 208 aircraft and secondly with inspections for composite materials.

## Morningstar—loss of control and collision with terrain

In the early morning hours on Oct. 6, 2005, a Cessna 208 cargo plane took off clean from Winnipeg with one pilot aboard. It climbed normally, but within minutes the performance of the aircraft diminished as ice built up on its critical surfaces. The situation quickly worsened and the aircraft crashed, killing the pilot.

The TSB did not wait until the investigation was complete to communicate with our international partners and to make our safety recommendations. In January 2006, both the TSB and the NTSB made the following recommendations to advance safety for the more than 1,600 Cessna 208s flying worldwide: *Cessna 208 pilots: (1) do not take off into anything more than "light" icing conditions and (2) maintain 120 kts minimum speed in icing conditions. Action taken: the FAA issued airworthiness directives (ADs) stating Cessna 208 pilots must: (1) maintain 120 kts minimum speed in icing conditions and (2) immediately exit icing*

*conditions exceeding "light."* Transport Canada adopted both ADs.

The actions taken by Transport Canada, the FAA, and the manufacturer on design, training, and procedures are positive. I hope they will mean no more inflight icing accidents with Cessna 208s.

## Air Transat—Flight 861, loss of rudder

On March 6, 2005, an Airbus A310 took off from Varadero, Cuba. Seventeen minutes later, the crew heard a loud bang, followed by vibrations. Then the aircraft started to Dutch roll. The crew managed to descend, stabilize the aircraft, and return safely to Varadero. Once on the ground, the problem quickly became obvious: The rudder was missing. This occurrence did not garner a lot of attention with the public. After all, the aircraft landed safely and nobody died.

But it certainly intrigued TSB investigators, and they were determined to figure out what caused the rudder to fall off a modern aircraft. The Air Transat investigation is another stellar example of international cooperation resulting in positive and concrete action to advance aviation safety.

What was learned in the initial days of the investigation into the rudder's composite material regarding disbands, hinge damage, and fluid ingress led to Airbus issuing an all operators telex calling for the inspection of all aircraft equipped with these composite rudders. Four hundred and eight Airbus widebody aircraft were inspected worldwide. These fleet checks suggested inspection programs may not always find defects in composite materials.

When we learned this, the Board urgently recommended that

Transport Canada, the European Aviation Safety Agency (EASA), and industry come up with an inspection program to detect damage before it progresses. In the United States, the NTSB took similar action, reflecting the importance of international voices. Transport Canada and EASA heard us. Transport Canada is working with the National Research Council on inspection techniques to detect failures in composite materials, and EASA is working with Airbus.



Wendy Tadros

What followed was the development of early, consistent, and reliable detection programs for composite materials. This absolutely could not have been accomplished without solid investigative work and international cooperation. The implementation of the Morningstar and Air Transat recommendations are two of our successes.

Now, let's start by tackling a number of the hard issues in aviation safety today by talking about some areas that need more improvement. I would like to see greater uptake of the recommendations flowing from the MK Airlines, Air France, and Swissair investigations. These are not easy issues—if they were, they would have been fixed a long time ago. They are the tough issues, and I would like to try to make the case for why I believe these recommendations are so important. Perhaps if I can do that—if I can gain your support—we can get the ball rolling internationally and make aviation even safer.

#### **MK Airlines—reduced power at takeoff and collision with terrain**

Let's look at the investigation of the MK Airlines crash on Oct. 14, 2004, at the airport right here in Halifax. A Boeing 747 cargo flight took off using speed and thrust settings that were too low for its weight. It hit a berm at the end of the runway, crashed into the forest, and burned. All seven crewmembers died.

Major air investigations are often global in scope, and this one was no exception. This accident involved an American-built aircraft, registered in Ghana, operated by a Ghanaian-licensed crew working for a U.K.-based airline. Equally international were the investigators. Investigators from the United Kingdom, Ghana, and Iceland participated in this TSB investigation.

What's interesting about this investigation and the reason it's worth talking about is it was not a "one off." Indeed there were 12 similar accidents worldwide in which four aircraft were destroyed and 297 lives lost. When you see one performance accident, the inclination is to say, "Well, the pilot should have followed the SOPs." When you see multiple accidents around the world where actual takeoff performance differed from expected performance, you come to the conclusion that additional defenses are needed in the system.

That is why the TSB recommended that Canadian and international regulatory authorities require a takeoff performance monitoring system to ensure that crews of large aircraft will be alerted in time when there is not enough power to take off safely. Transport Canada committed to working with industry on the development of a takeoff performance monitoring system. This is a step in the right direction. The Board is hopeful that a solution can be found to eliminate this safety deficiency.

#### **Air France—runway overrun and fire**

This accident took place at Canada's busiest airport, beside Canada's busiest highway at rush hour. It would be an understatement to say the overrun of an Air France A340 at Toronto caught the world's attention.

On Aug. 2, 2005, with 297 passengers and 12 crew on board, Air France Flight 358 approached Toronto in a severe and rapidly changing thunderstorm with shifting winds and limited visibility. It came in too high and too fast. Touching down 3,800 feet

along the 9,000-foot wet and slippery runway, it simply ran out of room. The aircraft came to a stop in a ravine; and while the evacuation was not without its difficulties, everyone got out before fire destroyed the aircraft.

The TSB is grateful to the people from the Bureau d'Enquêtes et d'Analyses (BEA), EASA, Airbus, Air France, Transport Canada, and many other organizations for providing information and invaluable assistance to our investigators. Thanks to your participation, we developed a comprehensive analysis of the causes and contributing factors that led to seven recommendations to make air travel safer.

So, what did we learn? We learned this crew was not alone. Since the Air France accident in Toronto, at least 10 large aircraft have gone off runways around the world in bad weather. This tells us that the potential for landing accidents in bad weather remains. To make air travel safer, the TSB made seven recommendations. Five of them focus on crews and the need for mandatory standards, training, and procedures, and two are aimed at reducing the risk of injury following an accident.

The Board made recommendations asking that Transport Canada and the world's regulatory bodies limit landings in thunderstorms and require enhanced pilot training. Our investigation revealed that the Air France crew, like many others, did not calculate the landing distance required for the conditions at the destination. That is why we recommended that regulators require these always be calculated, so crews will know their margin of error. The NTSB made a similar recommendation following an accident in which a B-737 left the runway at Chicago's Midway Airport.

We also made two recommendations aimed at reducing the risk of injury following an accident.

We took a good, hard look at the terrain at the end of Canada's runways and found it can increase the risk of injuries to passengers and crews. To address this risk, the TSB recommended that Transport Canada require 300-meter runway-end safety areas or an alternate means of stopping aircraft. This will bring all of Canada's major airports in line with international benchmarks.

Lastly, we examined the evacuation. As you know, successful evacuations are measured in seconds. We found, despite directions to the contrary, many passengers stopped during the emergency to take their carry-on baggage with them. To improve evacuations, the TSB asked Transport Canada to require that passenger safety briefings include clear direction to leave all carry-on baggage behind.

While the response to many of these recommendations has been positive, we are concerned about the response on our recommendation calling for runway end safety areas (RESAs) or EMAS (Engineered Materials Arresting System). Let's not forget that in the past 25 years, at least one aircraft a month overran a runway somewhere in the world. It is my conviction that until this problem is faced *squarely*, the trend is bound to continue. I believe this important issue deserves more attention from the world's regulators, including Transport Canada.

#### **Swissair—inflight fire leading to collision with water**

Here in Nova Scotia, September 2 marked the 10th anniversary



sary of the night Swissair Flight 111 crashed off Peggys Cove. It is only fitting that I end with this investigation.

On that evening in 1998, Swissair Flight 111, a McDonnell Douglas MD-11, departed New York City on a scheduled flight to Geneva, Switzerland, with 215 passengers and 14 crew on board.

About 53 minutes later, while cruising at Flight Level 330, the crew smelled an abnormal odor in the cockpit. Their attention was drawn to the area behind and above them, and they began to investigate the source, which they thought was the air conditioning system. After further troubleshooting, they assessed there was definitely smoke and decided to divert to Halifax.

While the flight crew was preparing to land, they were unaware that a fire was spreading above the cockpit ceiling. Soon thereafter, the aircraft's FDR logged a rapid succession of system failures. The crew declared an emergency and an immediate need to land. About one minute later, radio communications and radar contact were lost, and the flight recorders stopped functioning. About five-and-a-half minutes after that, the aircraft crashed into the ocean with the loss of all 229 souls on board.

The crew did what made sense to them at the time. Knowing what they knew, we pieced together the sequence of events. We ran a number of detailed scenarios and concluded that based on the time available before the fire disabled the aircraft, the crew could not have landed the plane safely.

The Swissair investigation took four-and-a-half years. It was the largest and most complex safety investigation ever undertaken by the TSB. I continue to be heartened by the way in which so many people—from so many places—helped provide this investigation with its strength and purpose. Coordinated national and international efforts and the contributions of many hardworking people like *you* were absolutely invaluable.

This investigation led to a comprehensive report with the potential to change the face of aviation safety. The TSB made 23 recommendations, 14 during the investigation and 9 in our final report.

These recommendations fall into five broad categories: onboard recorders, circuit breaker resetting procedures, supplemental type certification process, material flammability, and inflight firefighting.

We are pleased to see that the Swissair investigation led to improvements that make flying safer. However, there are areas where we think there still needs to be more progress. Let me talk to you about three of those.

The first material to ignite in the Swissair accident was MPET insulation. When we discovered this we advised regulators. Canada, the United States, and France required the removal of MPET insulation from many aircraft. The TSB learned that, at the time, the flammability test to approve insulation materials was not rigorous enough. We were pleased to see this test replaced by the radiant panel test.

We would like it if MPET was removed from *all* aircraft or we would like to know *how* the FAA's alternative means of compliance will ensure insulation materials will not propagate fires. We would also like to see more stringent testing for all existing insulation materials.

Since the Swissair accident, crews routinely divert to land

immediately at the first hint of fire or smoke in an aircraft, and the International Air Transport Association and the Flight Safety Foundation have worked together to develop industrywide guidance on more effective checklist procedures for smoke and fire. This in turn resulted in some aircraft manufacturers making improvements to their aircraft flight manuals. These are positive steps.

What we would really like to see is international adoption of the emergency checklist template. We will also continue to focus attention on two areas: the need for designated fire zones and a systematic approach to inflight firefighting.

In the transportation world, aviation has led the way with requirements for FDRs and CVRs. With each investigation, we refine what data we need to figure out what happened. The Swissair recommendations are aimed at ensuring crucial data will be available to investigators. The upshot is the FAA now requires that any single electrical failure not disable both CVR and FDR. By 2012, the FAA will also require 2-hour CVRs and an independent power supply providing 10 more minutes of recording time. There has been progress for sure in this important area, and the FAA is leading the way. We would like to see 2-hour CVRs and an independent power supply as the international standard. We are looking to Transport Canada to harmonize these rules for all Canadian-registered aircraft.

One other outstanding recommendation we feel strongly about is the installation of image recorders. These recorders will help investigators to better understand what went on in the cockpit and with the aircraft. The NTSB also made this recommendation. That being said, the cockpit is a pilot's workplace and I understand why they would oppose greater surveillance. This resistance can be overcome only if the international community protects the confidentiality of all recordings. We must ensure they will not be released and will only be used to advance transportation safety.

Our success depends on supporting each other's work. I invite you to go to our website—[www.tsb.gc.ca](http://www.tsb.gc.ca). There you can learn more about the recommendations we have made during the TSB's 18 years. After taking a closer look at these reports, and where you find similar safety deficiencies, I urge you to carry the flag for aviation safety and adopt the TSB's recommendations as your own.

Earlier, I spoke to you about how the Morningstar and Air Transat investigations changed the face of aviation safety. And we have looked at how, as a result of the MK Airlines, Air France, and Swissair investigations, there has been much progress. This would not have been possible without your cooperation and dedication to aviation safety.

And while many recommendations have been implemented, I would like to see the face of aviation safety changed even more dramatically. I would like to see *all* of the recommendations from the MK Airlines, Air France, and the Swissair investigations effectively implemented.

International cooperation and information sharing are critical to advancing transportation safety. Let's work together to make sure that happens.

Tadros's keynote address opened ISASI 2008, the Society's 39th annual air accident investigation conference. ♦



# LEDERER AWARD RECIPIENT

## C. Donald Bateman Receives Lederer Award

By Esperison Martinez, Editor

Quiet, unassuming, soft-spoken, mannerly, in demeanor very much like Jerry Lederer is how this year's selectee for the coveted ISASI Jerome F. Lederer Award is best described. C. Donald Bateman, who prefers "Don," received the coveted award at the ISASI 2008 Awards Banquet held September 11 in Halifax, Nova Scotia, Canada.

All readers know the high esteem in which a person selected for the Award is held, so it might be expected that the person receiving the Award might be a bit piqued by lack of special attention at the place of the presentation. In an incident that perfectly reveals Don's nature, President Frank Del Gandio related to the awards dinner attendees how Don, upon his arrival at the seminar hotel after a tiring flight, was told that his room would not be ready for several hours—so without any complaints or demands, he and his wife settled themselves in comfortable lobby chairs to wait. "Which is where I stumbled onto them," said Frank, "and profusely apologized for any mix-up that may have caused the long delay. Don wouldn't hear of it, and said he 'enjoyed the rest.'" As the reader can imagine, a proper room was quickly made available for the Batemans.

President Del Gandio went on to introduce Don and make the presentation of the Award. The president's remarks very much illustrate the tremendous effort Don Bateman has put forth in fulfilling the requirement to receive the Jerome F. Lederer Award, which was created by the Society to honor its namesake for his leadership role in the world of aviation safety since its infancy: "outstanding lifetime contribution in the field of aircraft accident investigation and prevention."

President Del Gandio remarked: "I am honored to present the annual Jerome Lederer Award to C. Donald Bateman. He has been a member of ISASI since 1992, and Don can fairly be described as the person who invented the ground proximity warning system (GPWS) and, later, the forward-looking enhanced GPWS

(EGPWS). If Don never did anything else in his career, these tools alone might allow him to say that he has saved more lives in aviation than any other single person who has ever worked in the field.

"That is not an overstatement; Don's work has saved lives, and lots of them. To give you a sense of scale, from 1945 through 1974 the United States alone had 80 fatal CFIT accidents, which killed nearly 2,000 people. Since 1974, when GPWS was finally required on air transport aircraft in the U.S., we have had just three such accidents, all of which occurred abroad in developing countries. Since enhanced GPWS was required some 13 years ago, we have had no fatal CFIT accidents involving aircraft with an operating EGPWS unit on board. Don personally deserves much of the credit for virtually eliminating CFIT accidents in much of the world.

"But GPWS is not all that Don has accomplished. He also was a pioneer in the development of angle-of-attack indicators, autothrottle systems, windshear detection, and altitude awareness systems.

"So how did Don accomplish this impressive list? He did it by becoming a real student of certain kinds of accidents. For example, he is well known for having investigated scores of



PHOTOS: E. MARTINEZ

*President Del Gandio, left, introduces Bateman to the assembly.*

CFIT accidents not by kicking tin on site, but by flying the estimated flight paths of every civilian CFIT accident and many near-CFIT accidents that occurred in the U.S., Canada, and Mexico from the late 1940s through the late 1960s when CFIT accidents were brutally common. He filmed every flight path, collected original data, and noted where and when warnings could have averted each accident.

“Don did this work as an employee of Honeywell’s Flight Safety Technologies, where he is the chief engineer. In effect, Don operated a unit at Flight Safety Technologies that can be compared to Lockheed’s famous Skunk Works.

“In the 1970s Don began to publish his findings and his data and began developing the downward-looking GPWS. As computer and satellite technology improved, Don later was able to incorporate very accurate topographical maps that became the basis for “forward looking” enhanced GPWS. Don even convinced Honeywell to give customers free access to updates of the terrain database to ensure the continued effectiveness of the equipment.

“By honoring Don here today, ISASI joins a long list of organizations that have recognized his unsurpassed contributions to safety around the world.

“He is a two-time winner of the Flight Safety Foundation’s Admiral Luiz de Florez Award (1975 and 1998). He was recognized as a Laureate by *Aviation Week* in 1994. He received the New Zealand Air Safety Foundation Award in 2002. In 2003, Don was named a “Pathfinder” at the Museum of Flight in Seattle. He was recognized yet again by the Flight Safety Foundation in 2006 when he won the Laura Taber Barbour Air Safety Award.

“Don also has been inducted into the National Inventor’s Hall of Fame and he is a Fellow at the Royal Aeronautical Society. Don’s current title as Corporate Fellow at Honeywell demonstrates the respect that his peers have for his contributions.

“It is always an honor to introduce a giant in his field. It is



*Bateman spends time with scholarship winners, Melissa LaCoursiere, center, and Catherine Rickafort.*

especially a pleasure to do so when that giant has been a long-time member of ISASI. Ladies and gentlemen, please welcome Don Bateman.”

Throughout the president’s remarks, the audience could observe Don’s discomfort as his accomplishments, one after the other, were told. As he walked to the microphone, the 250 dinner guests arose in unison and gave a thunderous applause.

In keeping with his character, Don chose not to make a lengthy discourse about his selection, rather he recounted a story from his days as a youth, about 8, that he says was foretelling of his future career and was his introduction to accident investigation. In taking his audience back to the early 1940s, he told how he and a companion were looking out the window and saw a very bright flash of light. Being young and curious, they eventually went to see what it was, skipping school to do so.

The next day when his teacher asked why he hadn’t been in school, he was very forthright and said he spent the time at the plane crash scene, looking at the debris and watching the events. To prove his story, he pulled a piece of fabric from his pocket and handed it to the teacher, saying he had picked it up at the scene. The teacher examined the fabric, then looked sternly at him and scolded: “You did a terrible thing—you moved some evidence from an accident.”

“As punishment,” he said, “she had us write a two-page report on what we did, and what we saw. When she read it, she said to me ‘You know, you are going to be an engineer because you can’t spell.’”

When the laughter subsided, he closed by saying: “Thanks to all of you for the selfless work that you do. You are all true professionals, and it is a great honor to be here.” ♦

### Past Lederer Award Winners

- |                             |  |
|-----------------------------|--|
| 1977—Samuel M. Phillips     | 1994—U.K. Aircraft Accidents Investigation Branch              |
| 1978—Allen R. McMahan       | 1995—Dr. John K. Lauber  |
| 1979—Gerard M. Bruggink     | 1996—Burt Chesterfield   |
| 1980—John Gilbert Boulding  | 1997—Gus Economy   |
| 1981—Dr. S. Harry Robertson | 1998—A. Frank Taylor   |
| 1982—C.H. Prater Houge      | 1999—Capt. James McIntyre                                      |
| 1983—C.O. Miller            | 2000—Nora Marshal  |
| 1984—George B. Parker       | 2001—John Purvis and The Transportation Safety Board of Canada |
| 1985—Dr. John Kenyon Mason  | 2002—Ronald L. Schleede  |
| 1986—Geoffrey C. Wilkinson  | 2003—Caj Frostell  |
| 1987—Dr. Carol A. Roberts   | 2004—Ron Chippindale   |
| 1988—H. Vincent LaChapelle  | 2005—John Rawson   |
| 1989—Aage A. Roed           | 2006—Richard H. Wood   |
| 1990—Olof Fritsch           | 2007—Thomas McCarthy ♦   |
| 1991—Eddie J. Trimble       |  |
| 1992—Paul R. Powers         |  |
| 1993—Capt. Victor Hewes     |  |



# Silver Dart Salute

By John A.D. McCurdy aka Capt. Gerry Davis

*(The ISASI 2008 Seminar Committee honored the 100th anniversary of the construction of the Silver Dart at Baddeck, Nova Scotia, in late 1908, by featuring the biplane in the seminar's logo design. Made of steel tube, bamboo, friction tape, wire, and wood, the Dart was powered by a V-8 engine supplied by Glenn Curtis, which developed 35 horsepower at 1,000 rpm. John A.D. McCurdy piloted his design on its first Canadian flight from the frozen expanse of the Bras d'Or Lake on Feb. 23, 1909. It logged more than 200 flights. The legacy of the Silver Dart continues to live on, and was certainly enhanced by a special presentation made at ISASI 2008.)*

*Capt. Gerry Davis, an ISASI and ALPA member, donned the persona of John McCurdy and delighted the audience with a recap of the aviation pioneer's life and a "first person" account of the famous Silver Dart flight described above and its many achievements. He has flown more than 18,000 hours in 28 aircraft types over 31 years and has investigated or participated in three major fatal accidents including Swissair Flight 111 and a number of smaller non-fatal accidents. For 5 years, he served as the vice-chairman of ALPA's Accident Investigation Board.—Editor)*

I was born at Baddeck, Nova Scotia, where I spent the early years of my life. In 1906 I graduated from the University of Toronto with the degree of mechanical engineer. Early on I became interested in aviation and in the construction of a machine that would fly. Dr. Alexander Graham Bell also had a home at Baddeck, Nova Scotia, where he carried on experiments with flying machines. I grew up in the company of the Bell family and was a familiar presence at Beinn Bhreagh, the Bells' summer estate. I was later among a group of four young

men recruited by Bell and his wife, Mabel Hubbard Bell, to form the Aerial Experiment Association (AEA). As a boy, I had become interested in Bell's work and assisted him in his experiments.

At that time he was assisted by Simon Newcomb, the eminent mathematician, and Samuel P. Langley, secretary of the Smithsonian Institution. During the course of my studies at Toronto University, I used to return to Baddeck during my vacations and continued at these times to work with Mr. Bell and his associates.

The Aerial Experiment Association was formed in the summer of 1907. The members were Dr. Bell, F.W. Baldwin, Lieutenant Thomas Selfridge, U.S.A., Glenn H. Curtiss, and me. The United States Army was interested in the development of flight and therefore had Lt. Selfridge serve as its observer in the Association.

The AEA conducted experiments during the summer and fall of 1907 at Baddeck with tetrahedral kites, with motors, and with serial propellers mounted on boats. The first experimental flight carried out by the group took place on Dec. 6, 1907. The test aircraft, piloted by Selfridge, was a large, tetrahedral kite placed on pontoons called the Cygnet I. It was pulled by the steamboat Blue Hill on Bras d'Or Lake, Nova Scotia. Cygnet I reached a height of 51 meters and remained in the air for 7 minutes, but when it landed on the lake the towline was not released and the kite with Selfridge was pulled below the water's surface. The kite was destroyed, but Selfridge was rescued.

In December 1907, we decided to move to Hammondsport,



**LEFT:** John A.D. McCurdy at the wheel of the Silver Dart at Hammondsport, New York. **ABOVE:** "McCurdy," aka Gerry Davis, relates his story to ISASI delegates.

New York, where Mr. Curtiss had a factory, to build a glider. This move was made on December 24. We proceeded at Hammondsport to experiment with gliders and then to build machines that would fly; the members of the Association worked together, although each one in turn had general charge of the design of a machine.

The first machine built by the Association was called the Red Wing because of its color. The first engine Curtiss designed specifically for aircraft was used in the Red Wing. Casey Baldwin successfully flew it on March 12, 1908, for 97 meters. His second flight took him 37 meters, but ended with heavy damage to the aircraft. The Red Wing had no controls except an elevator (a control used to adjust the up and down motion, or pitch, of an aircraft's nose or tail), and it was this lack of control that led to its destruction.

Following the construction of the Red Wing, other machines were made. The next aircraft was named the White Wing, and the members of the Association developed controlled flaps on the wings, which improved stability. These control flaps were soon called ailerons by another well-known aviation pioneer, Hari Farman.

The White Wing was flown four times in 1908: first by Baldwin on May 18, for 82 meters; by Selfridge on May 19, for 73 meters; by Curtiss on May 20, for 310 meters; and finally on May 23 by myself for 183 meters, landing with a destructive crash in which I was slightly injured. The Association's next aircraft was the June Bug. It was flown many times between June 21 and August 31, with the longest flight lasting more than 3 kilometers. When it was flown by Curtiss on July 4, 1908, it set the record for being the first aircraft to fly one kilometer in the western hemisphere and received the Scientific American Trophy.

The one called the Silver Dart was designed by me. In this machine I made a flight on Dec. 12, 1908; however, it was the Dart's first Canadian flight, from the frozen expanse of the Bras d'Or Lake on Feb. 23, 1909, that drew the attention of the world. I remember the circumstances of that flight as if it were yesterday. It was a brilliant winter day and the ice of Baddeck Bay was completely free of snow. We wheeled the aircraft out of its shed on the shore amidst the incredulous stares and remarks of a couple of hundred spectators who had gathered to witness the event. Having taken my seat, the machine was released by men on skates. After a run of about 100 feet, it took to the air: I lifted the biplane about 9 meters off the ice, and I flew the entire length of Baddeck Bay.

I landed on the ice about one-half a mile away and taxied back to the starting point. One thing that impressed me was the look of absolute astonishment on the faces of the spectators, but the thing that stands out most in my mind of that event was the great pleasure and animation in Dr. Bell's face at the completion of the flight.

The younger members of our group did not immediately recognize the historic significance of this flight; however, Dr. Bell, being of mature judgment in these matters, seemed to have grasped its full significance and he therefore preserved a permanent record of the event by sending telegrams to the news centers of the world. These were the first public flights

**“We wheeled the aircraft out of its shed on the shore amidst the incredulous stares and remarks of a couple of hundred spectators who had gathered to witness the event. Having taken my seat, the machine was released by men on skates. After a run of about 100 feet, it took to the air. I lifted the biplane about 9 meters off the ice, and I flew the entire length of Baddeck Bay.”**

that had ever been made in aero planes. The following day, I flew the Silver Dart in a graceful 7-kilometer circle.

I continued flying the machine through the winter of 1909, making many flights and covering in all more than 1,000 miles. The flights that I made with the Silver Dart in Canada were the first flights that had ever been made in the British Empire.

In 1909 the Curtiss Exhibition Company was formed, and I took part in the work of this Company. For several years, I gave exhibition flights in practically every state of the United States east of the Mississippi River and also in Mexico. The purpose of these exhibitions was to advertise Curtiss machines and to obtain funds with which to carry on the further development of the aero plane. In 1909 I conducted the first wireless experiments at Sheepshead Bay Race Track and for the first time sent from an aero plane a wireless message.

After the first of January 1910, I carried on these experiments in Florida and succeeded in both sending and receiving messages. In 1910, I made the first flight across water out of sight of land flying from Key West, Fla., to Havana, Cuba, a distance of 110 miles. During this time, I frequently carried messages and passengers for the purpose of demonstrating the uses to which the aero plane could be put.

In the fall of 1914, I moved back to Canada and at the request of the government organized a training school for aviators for service in the war. This was the only aviation school in Canada, and we trained more than 600 men. I also organized as a subsidiary of the Curtiss Motor Company, the Curtiss Aeroplanes and Motors, Limited, of which I was president and general manager, and ran the school in conjunction with this Company, the students using the machines that were manufactured by us. This school was carried on for 2 years and during that time not a single man was hurt.

In later years, I worked in the aviation supply business. During World War II, I became assistant director of aircraft production for the Canadian government, and in 1947 I was named lieutenant governor of Nova Scotia.

Depending upon your viewpoint, I surmise that I have, out of pure interest and childhood fascination with all things mechanical, participated in some “watershed” events in the history of aviation in Canada. ♦



# DHC-6 Twin Otter Accident off the Coast of Moorea, French Polynesia

By Alain Bouillard, Investigator-in-Charge, Special Advisor to the BEA (Bureau d'Enquêtes et d'Analyses pour la Sécurité de l'Aviation civile) and Arnaud Desjardin, Safety Investigator, BEA Engineering Department



**Alain Bouillard** began his career as an air traffic controller for the French Air Force in 1968. In 1975, he joined the French Civil Aviation Authority working for the air Navigation Services at the Roissy Charles-de-Gaulle Airport. In his position as an engineer in aeronautical operations and air traffic management, Alain joined the BEA in 1992 and took part in numerous investigations in France and abroad. He was the investigator-in-charge for the Concorde accident in Gonesse (France). In 2003 Alain was appointed as regional and airport director in Rennes (France). In 2006 he came back to the BEA and became the special technical advisor to the director of the BEA. Alain is in charge of the investigation on the Twin Otter accident in Tahiti. He is a pilot with multiengine and instrument ratings. He holds the TBM700 and ATR 42 type ratings.



**Arnaud Desjardin** has a masters degree in aeronautics from the French National Civil Aviation School (ENAC). He joined the BEA Engineering Department in 2005, after 6 years in the U.S. developing software tools for the FAA's air traffic control system. He is now the head of Flight Recorder and Performance Division of the BEA. He has participated in major international investigations, including the Air France Airbus A340 in Toronto, the West MD-82 in Venezuela, and the Air Moorea Twin Otter in Tahiti.

## 1. Introduction

On Aug. 9, 2007, the DHC-6 Twin Otter registered F-OIQI, making an inter-island flight from Moorea to nearby Papeete in Tahiti, crashed into the sea shortly after takeoff. Nineteen passengers and one pilot were on board this scheduled 7-minute flight, planned at a cruise altitude of 600 ft. There were no survivors. Apart from a few pieces of wreckage, most of the airplane sank within minutes to a depth of about 700 m.

Because of its weight category and the date of its airworthiness certificate, the airplane was not required to have any flight recorders. However, it was in fact equipped with a CVR, which proved to be extremely useful for the investigation.

The BEA undertook two successive search missions: the first was aimed at assessing an area where the flight recorder might be. The second was to recover a maximum number of airplane parts from the sea floor, given

the previously determined location. The BEA had had experience in this field, the most recent being assisting in the recovery of the recorders from a B-737 off the coast of Egypt<sup>1</sup> and later from an Airbus A320 off the coast of Russia<sup>2</sup>.

## 2. Signal triangulation

The accident aircraft was equipped with a CVR. Pinger signals transmitted by the underwater locator beacon (ULB) on the recorder were set off on contact with water. A BEA directional hydrophone was used to determine the signal's bearing from several positions. Coupled with a GPS receiver, this allowed the charting of numerous measurements. In theory, these would define the zone from which the signal originated.

In reality, acoustic wave propagation depends on various linked parameters, such as salinity and water temperature, which vary with depth. In addition, when an acoustic wave propagates in the sea, it is subject to refraction, which generates multiple trajectories, especially when the sea bed slope is around 40% as is the case between Moorea and Tahiti. This meant that it was sometimes impossible to distinguish between a reflected wave and the direct wave signal. A total of about 40 measurements were made, as shown in Chart 1.

Commonsense and sound judgment were then necessary to “filter out” unrealistic bearing measurements. First, the ones that were obviously diverging from the others were eliminated. They were probably pointing to a secondary echo and not the direct signal. Secondly, knowing the actual conditions in which the measurements had to be performed, it would not be reasonable to say that the precision on bearing measurements was less than 10°.

Indeed, bearing readings were made with a magnetic compass

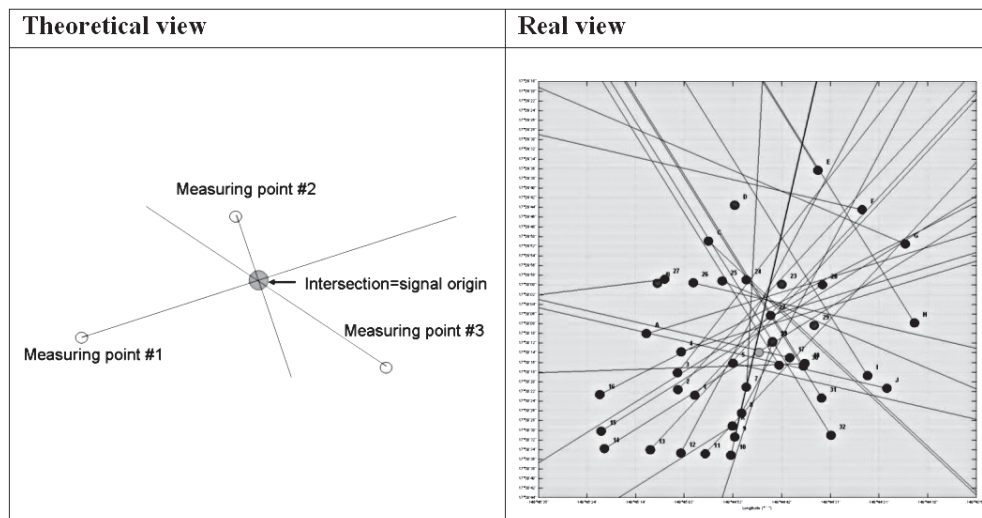

Chart 1

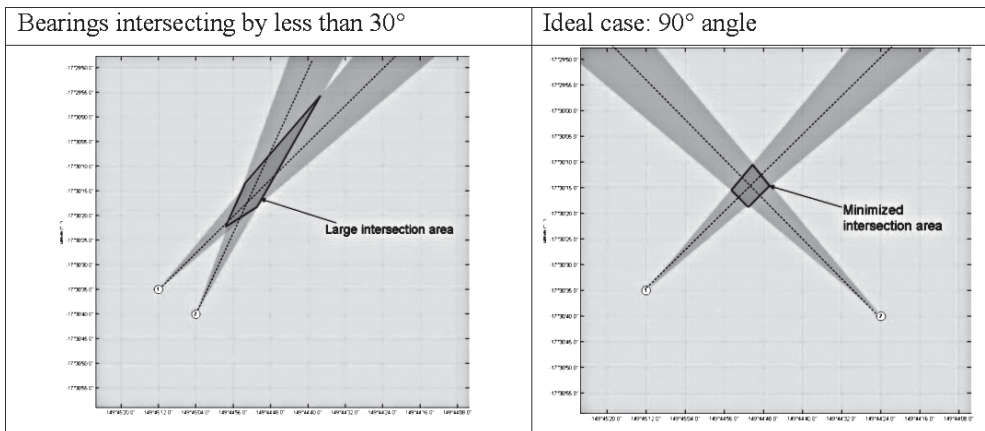

Chart 2

that had to remain horizontal to be accurate. Six-foot-high waves made this condition difficult, as did the fact that the bearings were determined by listening to the acoustic signal with a headset, adding a degree of subjectivity when it came to finding the direction from which the perceived signal was the loudest. The noise of nearby boats made this task even harder. It was then decided to ignore the intersections of the measurements with bearings that were off by less than  $30^\circ$ , because the  $10^\circ$  accuracy criteria make the range of possible intersections expand rapidly. In the ideal case, all bearings should intersect with a  $90^\circ$  angle (Chart 2).

This method enabled a more precise localization to be defined and limited the search zone to a circle of 260 m in diameter. The initial search zone before “filtering” would have been over 4,000 m in diameter.

### 3. CVR recovery

The second phase of the marine operations then began to recover the recorder and wreckage from the sea floor. The *Ile de Ré*, a 140-meter-long cable-laying ship was used for this mission (Figure 1). It is adapted to carry a heavy ROV<sup>3</sup> on its deck with its 50 tons of support equipment. The *Ile de Ré* has an advanced dynamic positioning (DP II) system that allows it to work even with unfavourable meteorological conditions and sea currents.

Within minutes of the first ROV dive (Figure 2), the tail section of the aircraft, containing the CVR, was spotted at a depth of 666 m.

The plan was to pierce the fuselage through the rear baggage door with a metal spear carried by the ROV. A cable connected at



Figure 1. The *Ile de Ré*, a 140-meter-long cable-laying ship.

the spear tip was then passed through the tail section and knotted around a fuselage bulkhead. The ship’s crane was used to lift the whole thing out of the water (Figure 3). All seemed to be going as planned until the tail section reached 50 m from the surface. At that moment, the attachment cable cut through the bulkhead that was being used to support the weight. The whole thing sank to the bottom, causing a 36-hour delay.

The tail section was spotted again by the ROV a few hours later. Since the CVR absolutely needed to be re-

covered, it was decided to cut through the side of the fuselage with the ROV’s mounted tools and to just rip the CVR from its rack. After more than seven hours of hard labor, the CVR was extracted and brought to the surface. The rest of the tail section, including the various flight control cables, was subsequently recovered from the same location.

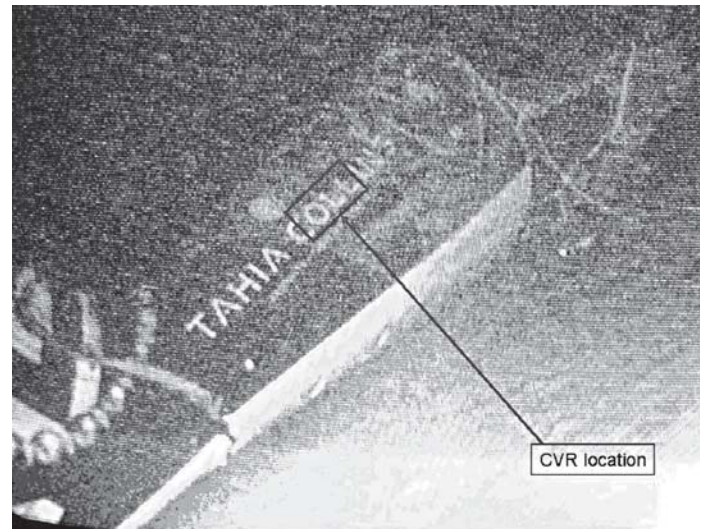

Figure 2

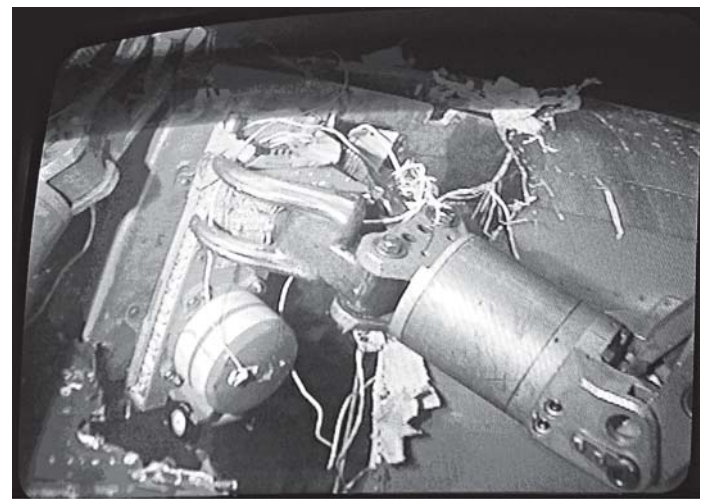

Figure 3



#### 4. EGPWS

The CVR was sent immediately to the BEA for readout. The aircraft was also equipped with an EGPWS<sup>4</sup>, which generated alerts in case of

- excessive rate of descent close to terrain (mode 1)
- loss of altitude after takeoff (mode 3)

Aural alerts from these two modes were recorded on the CVR. A partial vertical profile of the aircraft trajectory was later calculated based on the data obtained relating to the recorded alerts.

##### 4.1 Base data and assumptions

- The EGPWS installed on the aircraft was assumed to have been functioning according to Honeywell's product specification<sup>5</sup> at the time of the accident.
- The CVR events used as input for the calculations are shown in Table 1.
- At relative time  $t=0$  s, it was assumed that the aircraft was still climbing at a vertical speed of 600 ft/min.
- The mode 3 "Don't Sink" alert envelope for turboprop aircraft is based on altitude loss and radio altitude<sup>6</sup>:
- Mode 1 "Sink rate" alert (Figure 4) and mode 1 "Pull up" warning envelopes for turboprop aircraft (Figure 5A and B) are based on minimum terrain clearance and altitude rate:
- The aircraft was over the water from just after takeoff to the end of the flight. Therefore, for the purpose of this calculation, altitude and radio altitude are the same.

##### 4.2 Method

Altitude as function of time ( $t$ ) was modelled by a 4th degree polynomial equation:

$$Alt(t) = k_0 + k_1t + k_2t^2 + k_3t^3 + k_4t^4 \text{ (in ft)}$$

Vertical speed is the mathematical derivative of altitude:

$$V_z(t) = d Alt(t) / dt$$

$$V_z(t) = k_1 + 2 k_2 t + 3 k_3 t^2 + 4 k_4 t^3 \text{ (in ft/s)}$$

Altitude rate in FPM in descent (for mode 1 envelope equations) can be deduced from vertical speed in ft/s:

$$Altitude Rate (t) = -60 * V_z(t) \text{ (in FPM, or ft/min)}$$

The equations (Table 2) are based on the base data and assumed conditions of paragraph 4.1. Relative time  $t_1$  is the time at which the altitude was the highest.

Since the aircraft was assumed to still be climbing at  $t=0$ , we can say that  $t_1$  is greater than 0. Furthermore, since a "Don't sink" alert was recorded at  $t=4.1$ s, the aircraft was already descending at that time, which means that  $t_1$  is less than 4.1 s. Therefore  $0 < t_1 < 4.1$  s.

##### 4.3 Results

In Table 2 the equations (1) to (6) only have one solution<sup>7</sup> that

UTC Time	Relative time $t$ (s)	CVR Event
22 h 01 min 08 s	0	
22 h 01 min 09.2 s	1.20	Pilot utterance expressing surprise
22 h 01 min 12.1 s	4.10	EGPWS "Don't sink" alert
22 h 01 min 13.55 s	5.55	EGPWS "Don't sink" alert
22 h 01 min 15.2 s	7.20	EGPWS "Sink Rate" alert
22 h 01 min 15.95 s	7.95	EGPWS "Pull up" warning
22 h 01 min 17.55 s	9.55	EGPWS "Pull up" warning
22 h 01 min 19.15 s	11.15	Partial EGPWS "Pull up" warning
22 h 01 min 20 s	12.00	End of CVR recording—Sound similar to an impact with the surface

Table 1

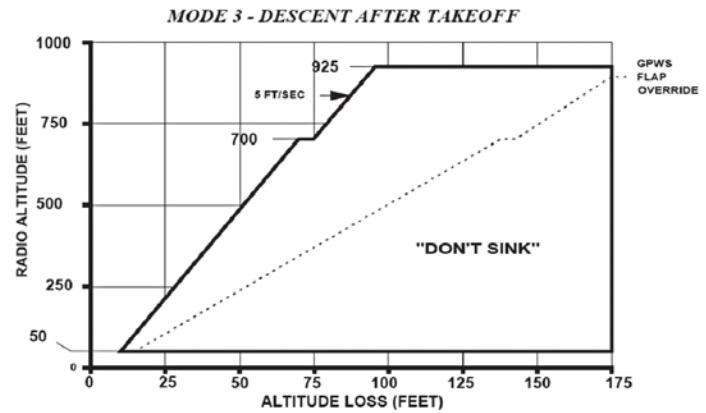

Figure 4

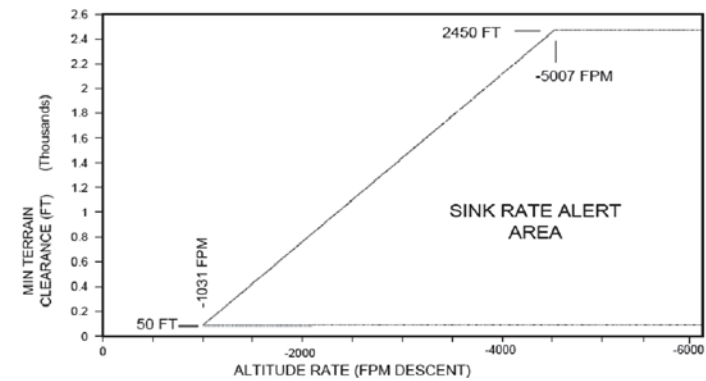
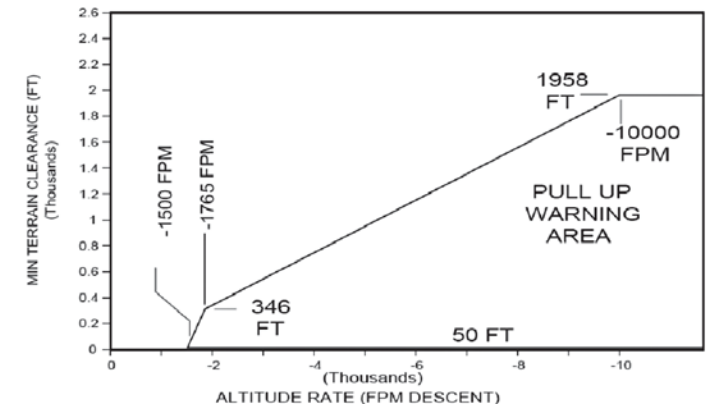

Figure 5A (above) and Figure 5B (below)



Equation #	Conditions	Equations
(1)	The aircraft was still climbing at a vertical speed of 600 ft/min at $t=0$	$V_z(0) = 10 \text{ ft/s}$
(2)	Altitude max reached at $t_1$	$V_z(t_1) = 0 \text{ ft/s}$
(3)	1st EGPWS "Don't sink" alert at $t=4.1$ s	$Alt(t_1) - Alt(4.1) = 5.4 + 0.092 * Alt(4.1)$
(4)	EGPWS "Sink Rate" alert at $t=7.2$ s	$Alt(7.2) = [-60 * V_z(7.2) - 1031] * 0.06036 + 50$
(5)	1st EGPWS "Pull up" warning at $t=7.95$ s	$Alt(7.95) = [-60 * V_z(7.95) - 1500] * 1.11698 + 50$
(6)	Impact with the surface at $t=12$ s	$Alt(12) = 0$

Table 2

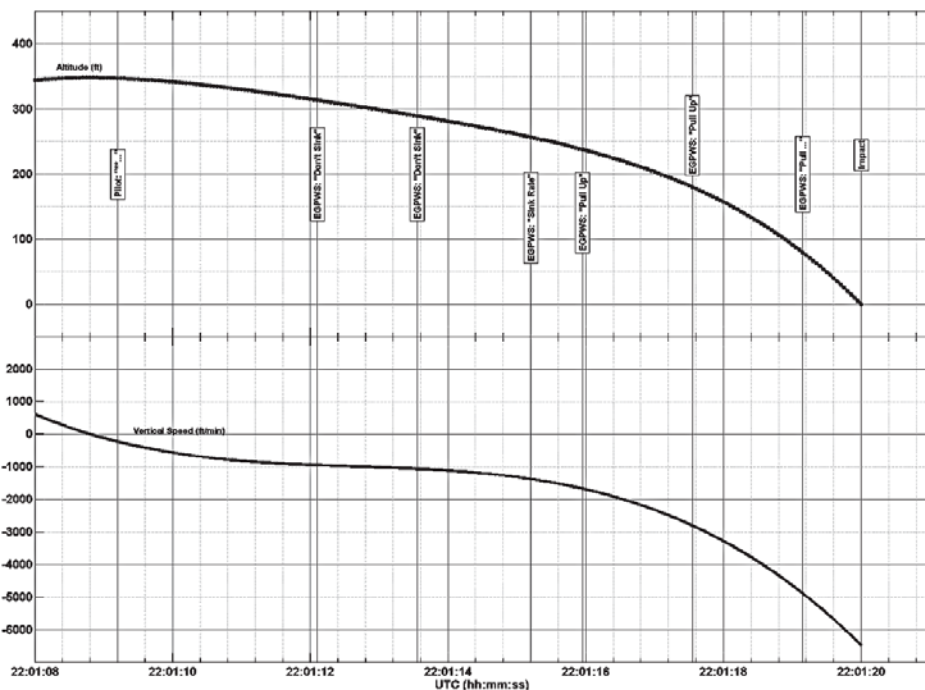

Chart 3

complies with the condition  $0 < t_1 < 4.1$  s. According to the model, the aircraft reached a maximum altitude of 350 ft at 22 h 01 min 08.8 s. The vertical speed when it struck the water was 6,500 ft/min.

Alerts and warnings generated by a Honeywell GPWS simulator matched the sequence of those recorded on the accident airplane's CVR (Chart 3).

### 5. Further tests

To understand the airplane's final path, as described by the witnesses and reconstituted on the basis of the GPWS alerts and warnings, a series of flight tests were scheduled. These were designed to validate the calculated flight path in case of a rupture of the elevator cable during flap retraction.

The flight tests confirmed both airplane pitch-down movement at the time of flap retraction and that the airplane's flight path was the same as that predicted by the theoretical method described above. All of the tests performed led to the conclusion that the rupture of the cable was the cause of the loss of pitch control.

The initial examination of the elevator cable recovered from the wreckage showed that it was 50% worn at the location of the rupture. However, the maximum possible pilot input force on the control column could not, in fact, cause a cable rupture, even where there is 50% wear.

It was thus essential to determine the rupture sequence in a step-by-step manner. Extensive further testing was undertaken to try to identify what additional force or forces could have had an impact on the events that led to the fatal rupture.

As of today, most of these tests have been completed and others are still awaiting validation, but the results obtained so far

have given us a clear direction to follow for our conclusion of the investigation. ♦

### Endnotes

- 1 B-737-300 registered as SU-ZCF on Jan. 3, 2004, off Sharm El Sheikh, Egypt.
- 2 A320-211 registered EK-32009 on May 2, 2006, off Sochi, Russia.
- 3 Remotely operated vehicle.
- 4 Model : Honeywell, Mark VI.
- 5 Document reference: DWG NO. 965-1180-601, Rev A. All equations and envelope diagrams are extracted from this document.
- 6 Selection of the GPWS flap override function increases the allowable altitude. This allows optional pattern work to be performed without unwanted warnings. It is assumed that it was turned off for the accident flight.
- 7  $t_1 = 0.8$  s;  $k_0 = 344.1897$ ;  $k_1 = 10.0443$ ;  $k_2 = -7.3787$ ;  $k_3 = 0.9733$ ;  $k_4 = -0.0523$ .



# SR 111—Why Did They Die? Why Do We Refuse to Learn? The Swissair MD-11 ‘Modi-Plus’ Program in Today’s SFF Environment

By Capt. Timothy Crowch



*Capt. Timothy Crowch was a professional airline pilot for 32 years—of which 25 were spent with Swissair, 15 years as a senior captain on MD-11s, and more than 20 years as a specialist in accident investigation and flight safety program management. In 2004, he resigned his aviation career and completed an MBA in Lausanne. He embarked on a*

*new journey as a forensic investigator, offering expert assistance to large law firms and the insurance industry as well as producing safety training programs for other complex industries based upon aviation methodologies. His company, Advanced System Safety Management based in Switzerland, is a leading provider of training courses in patient safety and safety programs for Swiss hospitals, clinics, and other healthcare institutions. This has also been extended to the nuclear power industry and large shipping fleets. He is a member of the Expert Witness Institute and a Fellow of the Royal Aeronautical Society, both in London, and is approaching 20 years of membership in ISASI. Flying has now become his hobby, with an amphibian based in Finland.*

## 1. Introduction

“Dad, Dad, wake up. It’s Swissair. There’s been an accident.” This is how my then 10-year-old daughter woke me at 6:15 on Sept. 3, 1998. She was on her way to school.

She handed me the phone, and my colleague at the other end said simply, “Tim, sorry to wake you. I know you have your check today, but an MD-11’s gone down.” I was asked for some advice on immediate matters and when I would be available to help. For me, it was to be a long day—following my 8-week MD-11 transition course, that day was my final line check to two West African destinations I had never before seen.

I do not think I need tell anyone in this room how I felt, especially when being told that the plane was lost in cruise—not in the almost customary takeoff or approach and landing phases. When told it was the New York-Geneva flight, my mind flashed to my course colleagues and their whereabouts as this route was always used as a training pattern. The initial news reports were listing the crew as 15, indicating that it was a training flight. Later the number was revised to 14.

On arriving at work at about 11:00, there were candles burning throughout our Operations Center at Zürich Airport. The mood inside was as grey and somber as the frontal weather outside. Some of the office staff were in tears. Some crewmembers arriving had not heard the news. The crew briefing I gave at 11:45 was then to prove the most severe test in CRM, especially

having learned the names of the lost flight crew beforehand. Capt. Urs Zimmermann had been one of my flight instructors on my original command course. F/O Stephan Loew had flown with me regularly on the A320.

The airline operation had to continue, though. I was heading for Douala and Libreville. I had a team to lead and 240 passengers to transport safely.

I can remember sitting in my seat awaiting pushback, as the heavens continued to cry their tears upon us, looking around and thinking that none of this equipment, none of the checklists, procedures, and the training I had just completed, had been able to save them. All of my colleagues and 215 others had perished.

Why had they died? Hell, what could have happened to one of our MD-11s?

## 2. From SR 111 to the “Modi-Plus” Program<sup>1</sup>

That was then; 10 years and a week later here in Halifax we know. With all honor and respect to the Canadian Transportation Safety Board (TSB) and all who assisted Vic Gerden’s team, we know as much as we shall ever know. Subsequently, when SR Technics removed the inflight entertainment systems from the remaining MD-11s, it became even more of a wonder that we had not lost another; such had been the damage to the electrical buses and infrastructure caused by the contractor, who had installed the systems for the airline—low bid. I shall say no more other than to highlight two of the TSB’s findings:

- There were no built-in smoke and fire detection and suppression devices in the area where the fire started and propagated, nor were they required by regulation. The lack of such devices delayed the identification of the existence of the fire and allowed the fire to propagate unchecked until it became uncontrollable.
- There was a reliance on sight and smell to detect and differentiate between odor and smoke from different potential sources. This reliance resulted in the misidentification of the initial odor and smoke as originating from an air conditioning source.

I am not here today to talk about this accident but rather what the airline achieved with those remaining MD-11s in what became known internally as the “MD-11 Modification-Plus Program” (Modi-Plus).

The purpose of this Swissair internal program was threefold, concentrating mainly on the following three areas:

- reducing and minimizing the vulnerability of the aircraft in significant areas,
- improving smoke detection and fire fighting possibilities, and

- improving cockpit instrumentation in case of total electrical failure.

As Swissair had to coordinate such actions within Boeing, the TSB, the FAA, the Swiss FOCA,<sup>2</sup> and internally, it took some considerable time to arrive at approved solutions for the above-mentioned criteria.

Maybe it ought to be noted that Boeing was not at all eager to implement these modifications or make them available to other operators of MD-11s. They totally rejected the idea of making them service bulletins or ADs.

We had already known for years that Mylar insulation blankets were highly flammable, yet we, as an industry, did little to nothing. Swissair, on the other hand, responded expeditiously. Initially, all Mylar insulation material was removed from the most critically significant areas during the Modi-Plus modifications and was replaced with more fire resistant metalized Tedlar. This product passes the more rigorous test (than the simple vertical flame test) developed by the U.S. FAA involving a combination of radiant heat and direct exposure to flame to qualify thermal acoustic blanketing in aeroplanes. The replacement of the remaining blankets in the rest of the aircraft was completed during each aircraft's subsequent heavy maintenance visit (HMV). The first aircraft was scheduled for modification in July 2001, and the program would be completed on all remaining 19 MD-11s by February 2002.

Then came the clever engineering, which formed the backbone of the aircraft's transformation and, in my opinion, sets a standard for the entire industry to emulate—especially today.

The greatest obstacle faced by our crew, and by countless crews before and since, was their inability to *see* what was happening to their aircraft. For years we have had fire and overheat sensing in our engine cowlings. We have similar devices in our cargo holds, but the largest volume of an aircraft consists of the aircraft's cabin and here—can you believe it—we still have nothing, except heat-sensing Halon extinguishers in the lavatory waste containers! And why do we have these? As the result of another fatal fire and smoke accident, a Varig B-707 in Paris in July 1973. A total of 123 persons out of a total of 134 died when they were overcome by smoke during the evacuation. The fire was deemed to have started in an aft toilet area.

For the remainder of any aircraft, from the flight deck to the aft pressure bulkhead, in the 21st century we are still relying upon the human nose as the only fire and smoke sensor. The nose can, however sense only the presence of a smell. It is not directional, it cannot locate a source with any accuracy, especially under time pressure. With the power of air conditioning systems and recirculation fans, this difficulty of location is exacerbated. The majority of smoke and fire sources will be invisible to the human, hidden behind decorative paneling. The human (even a trained crewmember) and lacks the tools and the knowledge for dismantling this structure, has no knowledge of what lies behind it. And, even if he/she were able to locate the source, there is little chance that this could be fought for more than a period of approximately 15 minutes. The standard 2-pound-sized Halon bottle is totally inadequate to confront and overcome a persistent fire in an inaccessible location within the cabin. Whereas a considerable number of bottles are scattered throughout the cabin, it must be assumed that several will be wasted during initial attempts to fight the fire. Access is never ensured and effective smothering of the site even less so. The bottles are usually of the total discharge

variety, not on-demand. They will not suffice for 2–3 hours of fire fighting; for some reason we always expect fires to be extinguished within very few minutes and crew training reflects this.

The Swissair MD-11 Modi-Plus Program included the installation of a Miscellaneous Smoke Detection System (MSDS). This is made up of

- a series of dual-loop smoke detectors in the overhead areas of the Cockpit and the first-class galley,
- control electronics units,
- a miscellaneous smoke alarm panel,
- MISC SMOKE light push buttons on the glare shield and a miscellaneous smoke panel,
- no fewer than eight infrared video cameras (in addition to infrared illuminators)—three in the forward first-class galley overhead area, two in the flight deck overhead area, and three in the avionics compartment,<sup>3</sup>
- rerouting and separation of the cabling in the cockpit overhead area, and
- the installation of a new standby instrument resembling a miniature Primary Flight Display.

These were augmented by a system of piping (the Halon Delivery System, HDS) that would duct Halon extinguishant to the same monitored areas.

- Two large 10-pound bottles were installed in the forward galley, discretely covered and mounted on the forward bulkhead, to protect the galley ceiling area.
- A third large 5-pound bottle for the flight deck overhead was mounted in the pilots' wardrobe.
- A portable Halon bottle was positioned adjacent to the door and ladder that led through the flightdeck floor to the avionics compartment below.

The pictures generated by the cameras were intensely sharp in both focus and detail and were presented on a screen mounted in the center pedestal between the two pilots. Each of the eight cameras could be selected in turn by a rotary switch.

We were, nevertheless, still going to be hampered by the overall design of the aircraft and the concept of isolating one electrical system and one air system at a time in order to locate (hopefully) the source of the smoke. This procedure, even when modified, consumed copious amounts of the commodity we, as pilots, have so little of in such situations—TIME.

In order to reduce the risk of an electrical fire spreading with the same ferocity ever again, it was also decided that during the installation of the Modi-Plus systems, all Mylar thermal insulation would be stripped out of the aircraft and replaced with Tedlar. This entire modification took less than 3 weeks and cost approximately US\$750,000 to US\$1 million per aircraft.

The Modi-Plus Program was nothing other than a direct response to the Canadian TSB recommendations, many of which were made during the investigation and long before the final report was produced in March 2003.

For the first time, commercial pilots were able to see into the most intense part of their aircraft's electrical system, and in the event of their noses sensing overheat, burning, or smoke, the status of the electrical components behind the paneling could be monitored in detail. This became an invaluable tool for analyzing the risk presented by such a situation and in deciding the correct course of action—continue the flight, immediate diversion, or something more drastic. In 2003, I had my own personal

experience of an overheating relay in the galley overhead area over the South Atlantic at night, approximately 580 nautical miles southwest of Sal. Whereas I admit not being able to sleep thereafter during my rest period, it was most comforting to be able to see behind the panels—to see around corners, so to speak.

Having experienced using such a system in earnest, I cannot believe that 10 years after this horrifying accident we, as an industry, from the lawmakers to the manufacturers to the operators, are deliberately continuing to keep our flight crews in the dark.

Let us have a brief look at the status of smoke, fire, and fumes (SFF).

### 3. The continuing situation today

- SFF is the 4th leading cause of passenger fatalities preceded by loss of control, CFIT and specific component failure.
- There are more than 1,000 smoke events annually in the United States, 350 resulting in precautionary landings; 2,500 events worldwide.
- There is a 1:10,000 chance of an occupant experiencing an SFF event.
- Doors and/or cockpit windows should never be opened in flight.
- Halon is still regarded as being the best extinguishing agent.
- AC 25-9: smoke testing in a cockpit is switched off after 3 mins. It assumes this will happen in real life.<sup>4</sup>
- 60% of aircraft fires are electrical.
- Insulation materials *do* burn, especially when contaminated with maintenance fluids.
- Pilot and cabin crew training is still woefully inadequate—available extinguishant is, too.
- There is still no fire detection and suppression in unprotected areas (outside engines, APU compartments, and cargo holds).
- There are wiring anomalies in 100% of the world's fleet.

Following TWA Flight 800, a survey found 24 of 25 B-737s in line service had evidence of metal shavings in wiring bundles. The 25th did, too, but was still on the manufacturer's ramp at Renton and had never been flown!<sup>5</sup>

Without listing the sad chronology of FAA/JAA/EASA procrastination, we still have no internationally accepted and enforced programs for upgrading an aircraft's resistance to fire. In the same 10-year period, we still only offer our crews the ability to fight a cabin fire for 15 minutes. Why do we continue to assume that all fires will extinguish in that time? Is that because we assume that a well-trained crew will manage to have their aircraft safely back on the planet within that mythical 15 minutes?

No. And why am I so sure? ETOPS<sup>6</sup>!

Since the early 1980s with the advent of the A310 and B-767 twins, we have been continually extending the ETOPS limits from 60 minutes single-engine cruise distance from an intermediate alternate up to 180+ minutes today. For those not familiar with ETOPS, these flights include those not only over oceans but also over deserts—be they hot and sandy or frozen wastelands with a total absence of infrastructure.

The main criteria for qualifying an aircraft for ETOPS have traditionally been powerplant reliability, electrical power generation redundancy, and fire suppression within the aircraft's cargo holds. The pilots additionally have to undergo special ETOPS training, making them familiar with operating rules and the complexities of enroute fuel calculations, weather minima, etc.

At no time, though, are the crews ever expected to deal with the suppression of SFF in the cabin area for any period resembling the time/distance away from an intermediate alternate. No additional fire extinguishant is mandated, nor have any additional firefighting procedures been developed. It is simply and optimistically assumed that we will never be confronted by such a situation.

However, how often have I heard my late colleagues criticized for not having brought a seriously overweight MD-11 into a short runway of less than 2,700 m? We who know how the fire developed that fateful night all now know what they should have done—so we believe. Please, let us not forget that the SR111 fire went from a wisp of smoke to a raging inferno within 72 seconds. They trusted the manufacturer's checklists and procedures—after all, what reason did they have to doubt them? The manufacturer must surely have run through every known scenario during its more-than-75-year history. We pilots were led to believe that the system would solve the problem for us.

Now, we, who now know better, say that they should have “landed” (now that's an interesting word when discussing ETOPS!) within 15 minutes because we all know that we only have 15 minutes available before we risk losing control of a fire outbreak. History proves this. Or does it?

And yet, ETOPS is designed to take us up to 207 minutes away from a “landing” possibility. That is the thinking behind the concept so that we can operate all over the planet without any gaps in the mid-Atlantic or mid-Pacific route structure. And yet, we are told again and again to “get it down.”

I can remember the slightly amusing training semester in Swissair following SR111. The simulator refresher exercises were geared to getting the MD-11 down to 1,000 ft in the shortest possible time. This vision was most commendable, especially when considering the feat of the Air Canada DC-9 crew in Cincinnati in 1983. However, the cynic in me started to laugh. Down to 1,000 ft as quickly as possible? But doesn't a ditching or forced landing only begin at 1,000 ft? You certainly have not mastered the emergency with a level off at 1,000 ft.

So, I was forced to enquire “then what?” And there was silence.

Had SR111 been at 30° west when the fire broke out—what would have been expected of the crew then? This could be termed the third injustice a pilot faces in the SFF scenario. Firstly, the pilot is blind to the source. Secondly, firefighting capabilities are limited. And thirdly, he/she has no training in the ultimate rescue procedure of his/her aircraft. We have never taught a modern commercial pilot how to ditch his/her aircraft. This must be the only emergency that a simulator cannot replicate. We inform passengers every day on how to get out of the aircraft on water but have never spent a minute teaching a pilot actually how to get onto the water. This is made all the more incomprehensible when the statistics above are considered for their implications on modern air transports.

Data exist everywhere on the ditching characteristics of aircraft. The manufacturers have data, the various military services possess data—often based upon firsthand experience. Why can this not be shared with operating crews? Why does the subject, to this day, remain taboo?

At a seminar a year ago at the Royal Aeronautical Society in London on the subject of smoke, fire, and fumes, a debate ensued following several quality presentations including one by Capt. John

Cox, president of Safety Operating Systems and an ISASI member. One retired captain, formerly flying heavy twins, said most forcefully that he would never put a flyable twin down on water. This strident opinion forces us to ask, what is the alternative? Assuming you do know how to do it, you face the second nightmare—namely, do you fly a serviceable aircraft onto the surface while you still have it under control or do you wait until you lose one critical system after another as occurred on our MD-11 until the aircraft becomes unflyable? Based upon established checklists, procedures, and lack of emergency landing training, pilots are still far from being in a position to debate this question on a well-informed basis. Pilots in the 21st century should, on the contrary, be well-trained and equipped to handle this real danger, as I am sure the opinion of the retired captain prevails within much of the flying community. We choose to ignore this debate at our peril.

While considering this matter, we might also reflect on the fact that pilots may find themselves with little choice to be made should there be a similar repetition of the Air Transat event in August 2001 or the British Airways B-777 event in January this year, were it in mid-ocean rather than below 1,000 ft on final approach.

For some quite inexplicable reason, the procedures for ditching and forced landings are still excluded from the pilot training syllabus—inexplicable, as no-one has a well-researched explanation as to why they are. To counter most proffered arguments, a pilot experiences any number of engine failures in a simulator in various phases of flight to the point that his/her reaction to such becomes almost instinctive. Yet, the pilot may never experience an actual engine failure in a 40-year career.

#### 4. Where now?

As an industry, we are doing ourselves no favors by brushing this “burning” issue under the carpet. Not a day goes by without someone proclaiming aviation’s admirable safety record, but on the issue of SFF we can only hang our heads in shame. We are too good an industry to rely on the “luck” factor. We have had enough fires in our history to imagine we would have been shaken up from our slumbers and nonchalant attitude. We should have been kicked out of our lethargy at the latest in 1998. Sadly, this is clearly not the case.

Commercial considerations have driven the ETOPS debate; commercial decisions have dictated the expenditure on every aspect of aviation. However, I am certain that all the facts we require to make aircraft safer from the threat of fire in the future are already in our possession and have, in all probability, been for a long time.

Swissair’s reaction to SR111 proves that action *is* possible; it has also demonstrated one good example of a means to mitigate the threat. It is certainly not the only method but any others are not well-known.

Swissair’s reaction was to act upon the TSB’s recommendations—there is no excuse for the entire industry not to follow the same course of action.

In closing, I recall the renowned former UK AAIB investigator, Eddie Trimble. At the ISASI seminar in Barcelona also exactly 10 years ago, he said, “If we fail to implement the recommendations arising out of an in-depth accident report, the next time I am called out to a crash site, I might just as well go to the beach.”

Implementation is the point at which the aircraft accident investigation process stalls. In the area of smoke, fire, and fumes, I ask honestly, for how much longer can we allow this to persist? This should be a point worth reflecting upon during a visit to the tranquil site of Peggys Cove.

SR111—“Why did they die? Why do we refuse to learn?” ♦

#### Endnotes

<sup>1</sup> This program was managed and driven throughout by Capt. Ruedi Bornhauser, the MD-11 chief technical pilot for Swissair. Without his tireless efforts, the realization of Swissair’s Modi-Plus would never have been achieved. Much of the information contained within this paper and several of the accompanying PowerPoint slides are courtesy of Capt. Bornhauser.

<sup>2</sup> Swiss Federal Office of Civil Aviation.

<sup>3</sup> In many respects, the camera installation reflects the need cited by the UK’s Air Accidents Investigation Branch (AAIB) for better fire detection in inaccessible areas of the aircraft. This finding stemmed from the AAIB’s investigation of a 1998 arcing event in the avionics bay of a United Airlines B-767 that forced the crew to abandon its westbound transatlantic flight and divert to London’s Heathrow Airport.—David Evans, *Avionics* magazine, October 2001

<sup>4</sup> In October 1993, a Swissair MD-80 departed from Munich to Zürich. Within minutes of takeoff, smoke developed in the cockpit. Again, it was initially difficult to locate the source, but this was eventually discovered by a cabin crewmember as she stood in the doorway. It originated from the overhead panel. The checklist called for reducing the electrical system by first switching off the right and then the left generator. Smoke built up rapidly in the cockpit to the extent that the instruments were barely visible and visual flight from time to time became impossible, necessitating numerous control changes. The window became coated in soot almost immediately. The aircraft landed safely back in Munich within minutes and was evacuated. The electrical failure was subsequently traced to the emergency power switch on the overhead panel—the switch to be used in the last-ditch attempt to save the aircraft. Once more, an aircraft was saved thanks to the proximity of an airport with excellent air traffic control and facilities. (BFU Germany – EX 003-0/93)

<sup>5</sup> Source of statistics: With thanks to Capt. John M. Cox FRAeS—president, Safety Operating Systems.

<sup>6</sup> Extended Range Twin Operations.



# Causation: What Is It and Does It Really Matter?

By Michael B. Walker (MO4093), Senior Transport Safety Investigator, Australian Transport Safety Bureau



*Michael B. Walker is a senior transport safety investigator with the Australian Transport Safety Bureau (ATSB) and has been with the Bureau since 1995. His primary role is to investigate human and organizational factors, and he has also been actively involved in developing investigation methodology at the ATSB. Mike has a Ph.D., masters, and honors degrees in psychology and human factors, and a diploma of transport safety investigation.*

## Introduction

Given recent interest in replacing or augmenting the term “causes” with “contributing factors” in ICAO Annex 13 (ICAO, 2008), it is timely to have another look at the concept of causation. The paper approaches the topic by examining several aspects of legal proceedings and safety investigations: the purpose of an investigation, the role of causation in an investigation, terminology, definitions, linking approach, standard of proof, and level of guidance for making judgments. The key point of the paper is that, because legal proceedings and safety investigations have different purposes, they should have different approaches to causation; unfortunately, the approaches are often similar.

The paper also discusses how the ATSB has approached causation as part of its enhanced investigation analysis framework. An overview of this framework was provided by Walker (2007), and a more detailed discussion of how concepts such as causation and standard of proof were addressed was provided in a recent ATSB research report (Walker & Bills, 2008). This paper is a short summary of the latter report, and the interested reader is referred to the full report for further details.

The subject of causation has been a matter of significant controversy in the aviation safety field (e.g., Rimson, 1998; Wood & Sweginnis, 2006). The paper does not attempt to review previous discussions, but hopes to offer a few new ideas that may be of use to organizations interested in revisiting this challenging concept.

## Purpose of investigations

The definition of cause in fields such as philosophy and law has been a matter of significant debate and disagreement. However, there does appear to be a widely held view that what is determined as being a cause of a particular event depends on the purpose of the inquiry or investigation (Doyle, 2002; Wright, 1988).

A variety of legally based investigations may follow an occurrence (accident or incident). These include regulatory or administrative investigations whose purpose is to determine whether any requirements have been breached or to assess the suitability of an individual or organization for ongoing operations. For such investigations, determining if the individual’s or organization’s actions played a causal role in the occurrence is not relevant. The

legal proceedings of interest to this paper are civil proceedings that arise from an accident. The purpose of such proceedings is the allocation of responsibility for the accident, or at least for the damage or loss resulting from the accident. This purpose is directly achieved when the findings of the proceedings are made (i.e., the findings state who or what is responsible).

As outlined by ICAO (2001) and others, the purpose of a safety investigation is to enhance safety (or prevent accidents), and it is not the purpose to apportion blame or liability. Safety investigations do not directly achieve their purpose, but information obtained from investigations can be used to enhance safety in many ways:

- Identifying safety issues that could adversely affect the safety of future operations, and encouraging or facilitating safety action by relevant organizations to address these issues through recommendations or other forms of communication. This is generally the most effective way investigations can enhance safety.
- Providing information about the circumstances of the occurrence, and the factors involved in the development of the occurrence, to the transportation industry. Communicating such information provides valuable learning opportunities.
- Providing information for an occurrence database, which can then be combined with information from other occurrences and used proactively for research and trend analysis purposes and any necessary safety recommendations.

## The role of causation in investigations

In legal proceedings, determining causation is essential for achieving the purpose of allocating responsibility. An individual or organization cannot be held legally responsible for an accident unless their conduct has been shown to be a cause. In safety investigations, determining causation is obviously relevant but not essential for the purpose of enhancing safety. To explain this point, it is worth looking at the ATSB concept of “safety factors.”

The ATSB defines a safety factor as an event or condition that increases safety risk. As shown in Figure 1 (next page), a safety factor can be categorized in terms of whether it contributed to the development of the occurrence (or was a “contributing safety factor” using ATSB terminology). A safety factor can also be categorized in terms of whether it was a safety issue or a safety indicator. A safety issue is an organizational or systemic condition that can be reasonably regarded as having the potential to adversely affect the safety of future operations (e.g., problems with procedures, training, safety management processes, regulatory surveillance). In contrast, a safety indicator is any other type of safety factor (e.g., technical failures, individual actions, or local conditions such as workload), which may indicate the existence of a safety issue.

Each safety factor identified by an investigation fits into one of the boxes in Figure 1. Legal proceedings are interested in contributing or causal factors. However, for safety enhancement pur-

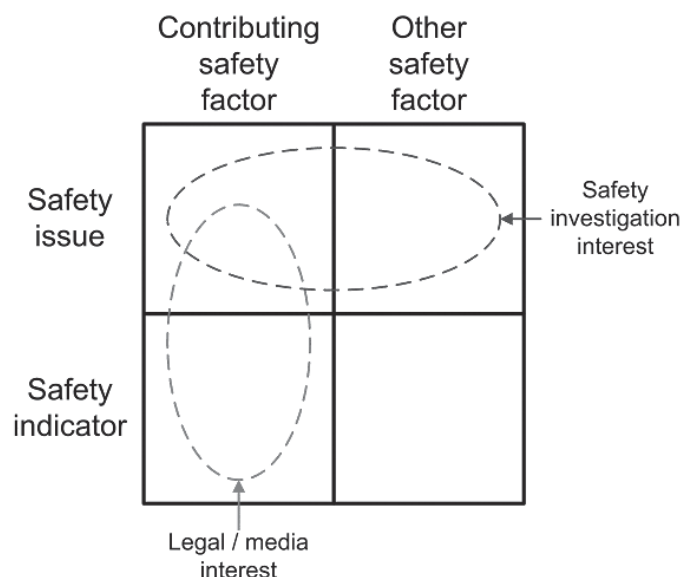

Figure 1. Overview of types of safety factors.

poses, importance should reflect the degree of safety risk for future operations. Therefore, the most important safety factors are the safety issues associated with the most risk, and not all of these will be identified during an occurrence investigation as being contributing safety factors.

Accordingly, safety investigations should ideally focus on identifying safety issues, regardless of whether they were contributory or not. However, to purely do this is not possible for a variety of reasons:

- Investigation organizations have various requirements in legislation and standards to determine causes or contributing factors (e.g., ICAO Annex 13).
- The public and other stakeholders expect safety investigation reports to identify and discuss the factors involved in the development of an occurrence.
- Some organizations will unfortunately appreciate the importance of a particular safety issue only if it can be shown to have actually been involved in the development of an occurrence.
- The concept of contribution provides a central organizing principle for an investigation. Safety investigations are not broad audits or examinations of an organization or safety system with unlimited resources. Although any safety factors that are identified during an investigation should be raised in an investigation report, regardless of whether they contributed or not, the search for potential safety factors needs to be pragmatically focussed in areas that are related to the circumstances of the occurrence, and the contributing safety factors that have already been identified. In other words, to be efficient and timely, safety investigations should not stray too far from the paths of contribution when searching for potential safety factors.

In summary, for pragmatic reasons causation does matter for safety investigations. However, the primary interest of safety investigations should be identifying safety issues, and causation should be viewed as a means to achieve this rather than as the end point itself.

### Terminology

Legal proceedings are concerned with determining the “cause” or “causes.” In the safety investigation field, organizations use a

variety of terms to describe the factors involved in the development of an occurrence. These terms are commonly based on “cause” (e.g., cause, causal factor, direct cause, probable cause, proximate cause, root cause, contributing cause, descriptive cause, explanatory cause), though other terms are also used (e.g., contributing factor, significant factor).

It is relatively common for an organization to use multiple terms. Some organizations differentiate terms on the basis of their degree of relationship to the actual occurrence. In other words, they use some terms to describe factors that have a closer or higher degree of relationship (e.g., direct cause, proximate cause) whereas other terms are used for factors that have a lower degree of relationship (e.g., contributing factor). Differentiating groups of factors in this way has the significant potential to lead to perceptions that the factors in the closer group are more important or associated with more responsibility for the occurrence than the other factors. As these factors will generally involve technical failures and individual actions rather than safety issues, such perceptions interfere with the purpose of safety enhancement.

Sometimes organizations differentiate terms on the basis of their potential for preventing recurrence (e.g., direct cause versus root cause). This approach emphasizes the importance of addressing the underlying factors. However, it also limits the focus of attention to factors involved in the development of the occurrence, and it does not clearly deal with important safety issues that may be identified that did not contribute.

Given these observations, there are advantages in just using one term to describe the factors involved in the development of an occurrence. There are also advantages in using a term such as “contributing factor” instead of one based on “cause.” Firstly, the term “cause” is commonly used in legal proceedings and therefore is commonly associated with the allocation of responsibility. The use of a different term can help minimize misinterpretation of a safety investigation’s findings as being synonymous with those of legal proceedings.

Secondly, when organizations use “contributing factors” or some analogous term together with “causes: or some similar term, the contributing factors are generally described as having a lower degree of relationship to the actual occurrence than the causes (e.g., U.S. Department of Energy, 1997). This means that the term “contributing factor” is more inclusive, and can therefore provide a richer picture of the factors involved in the occurrence.

For these reasons, the ATSB has chosen to use the term “contributing safety factor.” The word “safety” was added to emphasize the safety focus of its investigations.

### Definitions

Many legal theorists have proposed that the determination of causes in legal proceedings should be separated from the policy and judgmental aspects of determining which of the causes (if any) should be held to be legally responsible or liable (Stapleton, 2001; Wright, 1988). The latter part of the inquiry involves concepts such as “remoteness,” and whether any intervening acts (after the cause of interest) break the “chain of causation,” as well as the notion of the extent to which the damage was foreseeable.

However, this distinction between determining causes (without policy judgments) and then determining responsibility (using policy judgments) has often not been reflected in practice, with much confusion in the use of causal language (Wright, 1988).

Many also hold the view that policy and judgment issues are necessary for the determination of causation as well as the determination of responsibility. Part of this view appears to be associated with the lack of agreement on the appropriate test to determine causes.

Many different tests or approaches have been proposed and used for legal proceedings. The most common approach is the use of the “but-for” test, which states that an event or condition (usually an individual’s or organization’s conduct) is a cause of the damage of interest (for example, injury, death or other loss) if, but for the act or condition, the damage would not have occurred. In other words, if the cause had not occurred, the accident (or the damage) would not have occurred.

The but-for test (also known as the counterfactual conditional) is widely acknowledged to be simple and work well in most situations (Honore, 2001). There are some limitations with the test, such as “overdetermination,” although these problems are more salient when using the test for legal purposes and are less critical to other fields such as science (Stapleton, 2002). Various solutions have been proposed to overcome the limitations, though none appear to solve all the problems and none have been widely agreed in the legal field. Consequently, the but-for test is often supplemented by the use of “commonsense” and policy judgments when determining causes in legal proceedings, and the concepts of causation and responsibility are very closely related in such proceedings.

In the safety investigation field, ICAO Annex 13 defines “causes” as “actions, omissions, events, conditions, or a combination thereof, which led to the accident or incident.” Such statements describe what types of things causes can be but provide minimal indication of their meaning. Some organizations have adopted the Annex 13 definition, whereas some others appear to have no clear definition. Nonetheless, the but-for test has gained widespread acceptance in the safety field as a means of defining cause-related terms (e.g., Hopkins, 2000; ICAO, 2003; NASA, 2006; USAF, 2006).

The term “contributing factor” is often used without any definition. When it is defined, the definitions can vary widely. For example, it has been described as something that increases the likelihood of an accident (U.S. DOE, 1997), or something that may have contributed to an occurrence (NASA, 2006). It has also been defined in terms of the but-for test (Australian Standard 4292.7-2006).

The but-for test, also known as the counterfactual conditional, is therefore a common part of legal proceedings and safety investigations. It is also widely used in other fields. Accordingly, the ATSB used the test as the basis for its definition of a “contributing safety factor.” More specifically, it defined a contributing safety factor to an occurrence as a safety factor that, if it had not occurred or existed at the relevant time, then either

- the occurrence would probably not have occurred or
- adverse consequences associated with the occurrence would probably not have occurred or have been as serious or
- another contributing safety factor would probably not have occurred or existed.

However, there are two important aspects of the ATSB definition that are different to how the but-for test is generally used. These include the linking approach and the standard of proof included in the definition.

## Linking approach

There can be significant differences in but-for definitions depending on what is the effect or subject being explained. In other words, what does the proposed cause or contributing factor link to? There are two basic approaches: the relative-to-occurrence approach and the link-by-link approach (see Figure 2).

In the relative-to-occurrence approach, the subject is the occurrence itself. In other words, if the safety factor did not happen, then the occurrence would not have happened. This is the approach used in legal proceedings, with the subject being the accident or the damage resulting from the accident. It is also often used in safety investigations, with the subject being the occurrence, or in some cases also the severity of the consequences arising from the occurrence (e.g., Australian Standard 4292.7-2006; ICAO, 2003).

In the link-by-link approach, the subject can either be the occurrence itself or another “cause” or contributing factor. In other words, judgments about contribution are made about the strength of links between factors, rather than made in terms of the overall relationship between each potential factor and the occurrence itself. The ATSB definition incorporates a link-by-link approach. Others have also advocated a link-by-link approach for safety investigations (e.g., Hopkins, 2000), and the International Maritime Organization has also recently adopted a similar definition to the ATSB, using the term “causal factor.”

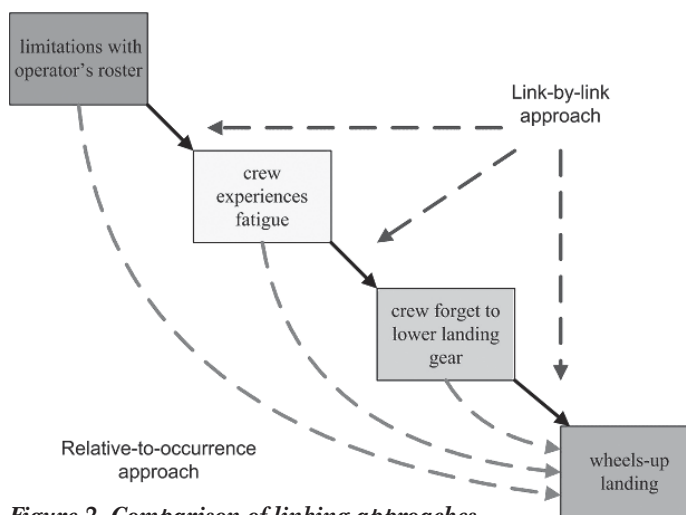

Figure 2. Comparison of linking approaches.

The relative-to-occurrence approach has merit when the purpose is to determine responsibility for an occurrence. However, there is a significant dilemma associated with the approach that fundamentally constrains its potential for enhancing safety; the most effective findings for safety enhancement (safety issues) are the most difficult to justify. As discussed above, for pragmatic reasons an investigation cannot stray too far from the paths of contribution when searching for potential factors. The more remote the investigation proceeds away from the occurrence when identifying potential factors, the more difficult it becomes to meet the relevant standard of proof for contribution or causation. As safety issues are generally quite remote from the occurrence, they are generally going to be less likely to be looked for or found to be contributing or causal.

In contrast, by making judgments about each link separately, the link-by-link approach has more scope to proceed more remotely from the occurrence. The approach therefore has the

potential to identify more safety issues (whether ultimately with sufficient evidence to be termed contributing or not), as well as providing more learning opportunities by providing a richer picture of the factors involved.

There are other advantages associated with a link-by-link approach compared with a relative-to-occurrence approach. A link-by-link approach can lead to simpler judgments about contribution and better enable an investigation to be more open and intellectually rigorous. In addition, a relative-to-occurrence approach is used in legal proceedings, and the findings of safety investigations conducted using this approach can therefore be readily interpreted in terms of a legal perspective. This association with legal proceedings has the potential for some parties to respond to safety investigation findings with future liability and compensation consequences in mind.

There are also potential problems with a link-by-link approach. Firstly, there may be a greater tendency to proceed too remotely from the occurrence and identify factors that cannot be practically addressed by any organization. This problem can be minimised with a clear definition of a “stop rule” and consideration of the concept of practicability when identifying potential factors.

A second problem is that findings about safety issues produced using a link-by-link approach can be misinterpreted by some parties as being based on a relative-to-occurrence approach. As a result, some of the findings about contributing and causal factors may be perceived by these parties to be weak or poorly supported. Such misinterpretation can interfere with an understanding of the importance of addressing the safety issues in order to reduce the risk of future accidents.

The potential for misinterpretation of the link-by-link approach can be minimized by clearly defining the types of findings and the approach being used by the investigation, and emphasizing that findings produced with the link-by-link approach should not be directly compared with findings produced by a relative-to-occurrence approach (see “The ATSB experience”). It can also be minimized by considering the standard of proof that is used for the links.

### Standard of proof

In the legal system, the term “standard of proof” is used to refer to the degree of certainty with which a contested fact (such as determination of a cause) must be established in order to be accepted or proven. Different standards of proof are applied depending on the implications associated with an erroneous decision for the parties involved.

In civil proceedings, the standard of proof is termed “proof beyond the balance of probabilities” in some countries or “preponderance of the evidence” in the U.S. This is a lower standard than that used in criminal proceedings (beyond reasonable doubt), with the general view being that the risk of an erroneous decision should be the same for both parties in civil proceedings, although only one party will have the “burden of proof.”

The civil standard is generally interpreted to mean that the matter of interest has to be found to have “more likely than not” occurred. However, the standard is not that straightforward. There is a general view that it is unreasonable to take the same approach to making findings for more serious matters as it is for relatively minor matters (Anderson, Schum, & Twining, 2005; Redmayne, 1999). As a result, decision-makers may vary the standard of proof required, or vary the standard of evidence (or quantity or quality

of evidence) they will accept before determining that the standard of proof has been met. Many aspects of these determinations are not well specified.

As far as the ATSB is aware, most organizations that conduct safety investigations do not clearly specify the standard of proof (or standard of evidence) they use when making findings regarding contributing or causal factors. In selecting an appropriate standard for its purposes, the ATSB was aware that the use of a high or conservative standard (such as “beyond reasonable doubt,” “almost certain,” or similar) would produce few contributing safety factors in most investigations, particularly in terms of safety issues. The ATSB was also aware that the use of a relatively low standard (such as “balance of probabilities”), combined with a link-by-link approach, could produce more contributing safety factors that would be perceived by many parties as having a relatively weak role in the overall development of an occurrence.

To achieve an appropriate compromise, the ATSB definition of contributing safety factor was aligned with a standard of “probable” or “likely.” Initially this was defined as meaning a likelihood of 75% or more, based on a conservative interpretation of research into what different parties considered different verbal probability expressions to mean. However, this was changed to a likelihood of more than 66% (or two-in-three chance) following the high-profile usage of that definition by the Intergovernmental Panel on Climate Change in early 2007.

Compared with legal proceedings using a relative-to-occurrence approach and a balance of probabilities standard, the ATSB approach will use a higher standard of proof for factors relatively close in proximity to the occurrence (that is, more than 66% versus more than 50%). But as an ATSB safety investigation proceeds to identify contributing safety factors more remote from the occurrence, the degree of relationship of the factors to the occurrence itself will generally decrease using the ATSB approach.

For example, consider the situation outlined in Figure 2. If the link between the roster problems and fatigue was assessed as being at least 67% likelihood, and the link between fatigue and the crew’s action was assessed as being at least 67% likelihood, then the resulting likelihood of a relationship between the roster and the crew’s action could be as low as 45%. The more links in the chain, then the lower the likelihood could be between the first (highest-level) factor and the occurrence.

The reduction in the likelihood between a higher-level factor and the occurrence itself over multiple links may not be substantial in practice. In many situations, the likelihood level for each link will be higher than the minimum required level of more than 66%. Nevertheless, for contributing safety factors that are safety issues, the balance of probabilities standard for a direct relationship to the occurrence itself may not be met. As a result, all that can be said in such situations is that, if the contributing safety factor had not existed, then the occurrence “may” not have occurred.

### Level of guidance

Making decisions about what events and conditions should be found to be contributing or causal factors can be difficult. To assist in making these judgments, investigators need more than clear definitions. However, for both legal proceedings and safety investigations, the means of examining the evidence and making determinations is usually not formally defined and relies extensively on the expertise of the decision-maker.



This does not mean to imply that some investigation approaches do not conduct a detailed, thorough, or high-quality examination of the available evidence when determining contributing or causal factors. However, to improve the consistency and rigor of the decision-making, a more systematic approach is warranted. In other words, there needs to be more science and less art.

To address this need, the ATSB analysis framework includes several elements to assist in the determination of findings. These elements include

- a structured and defined process for identifying potential safety factors.
- a process for testing a potential safety factor in terms of its existence, influence, and importance.
- a tool known as an “evidence table” for conducting a structured examination of the available evidence when doing the tests.
- lists of criteria to consider when evaluating items of evidence, evaluating sets of evidence, and making judgments on existence, influence, and importance.
- general guidance on critical reasoning principles.

### The ATSB experience

The ATSB has been using its new terminology (including “contributing safety factor”) in investigations reports since 2006. The most high profile example was the ATSB investigation into the fatal Metro 23 accident near Lockhart River on May 7, 2005, (ATSB, 2007). In a recent coronial inquest into this accident, aspects of its definitions were queried by one party and the coroner. These queries related to the standard of proof aspect rather than the definition itself, and they have been discussed and addressed in detail by Walker and Bills (2008).

However, during the investigation and inquest, it was apparent that there was some misinterpretation of the ATSB findings and its use of the link-by-link approach. For example, the Civil Aviation Safety Authority (CASA) chief executive officer made a news media statement on April 4, 2007, that he did not accept that CASA “caused the errors on the flight deck that resulted in the accident,” and that although there was “room for improvement” in CASA’s oversight processes, these problems could not be linked “directly” to the failures that occurred on the flight deck. However, the ATSB report did not state that CASA directly contributed to the crew’s actions or the occurrence itself. The ATSB report concluded that limitations with the design of CASA’s regulatory oversight processes contributed to it not being able to detect fundamental problems with the operator’s safety management processes. Using a link-by-link approach, these safety management problems were in turn linked through various risk controls and local conditions with the crew actions involved in the occurrence.

To minimize the potential for such misinterpretations in the future, future ATSB investigation reports will include clear statements to explain that ATSB investigations use a different methodology and will often produce different findings compared with legal proceedings or other types of investigation, and that the use of the term “contributing safety factor” should not be considered as being equivalent to “causes” in a legal sense, or reflect what the findings of a legal proceedings would produce.

### Conclusions

Causation is a complex concept, and to effectively address it

an investigation organization needs to consider many aspects. The ATSB has examined these aspects and developed an approach to causation that is tailored to the purpose of safety investigation.

Different organizations have different contexts, and not all aspects of the ATSB approach will be appropriate for other organizations. However, based on the ATSB experience, the following principles can be offered for those interested in reviewing or developing their own approach:

- Terms and definitions should be clearly distinguished from those used in legal proceedings.
- Contributing or causal factors should not be differentiated in terms of their degree of involvement with the occurrence.
- The importance of factors should be based on their future risk rather than degree of involvement with the occurrence.
- The definition of cause-related terms should have a broad scope for inclusion, and readily permit investigators to identify potential safety issues that are remote from the occurrence.

Terms and definitions need to be supported by a comprehensive investigation analysis framework to assist investigators in making judgments. ♦

### References

- Anderson, T., Schum, & Twining, W. (2005). *Analysis of evidence* (2nd ed.). Cambridge UK: Cambridge University Press. (Chapter 8.)
- Australian Standard 4292.7-2006. (2006). *Rail Safety Management Part 7: Railway safety investigation*. Sydney: Standards Australia.
- ATSB (2007). *Collision with Terrain, 11 km NW Lockhart River Aerodrome, May 7, 2005, VH-TFU, SA227-DC (Metro 23)*. Transport Safety Investigation Report, Aviation Occurrence Report 200501977. Canberra, Australia: ATSB.
- Doyle, J. (2002). Causation in the context of medical practitioners’ liability for negligent advice. In I. Freckelton & D. Mendelson (Eds.), *Causation in Law and Medicine* (pp. 379-398). Aldershot, UK: Ashgate.
- Honore, A.M. (2001). Causation in law. In E.N. Zalta (Ed.), *Stanford Encyclopedia of Philosophy*. Stanford University.
- Hopkins, A. (2000). *Lessons from Longford: The Esso Gas Plant Explosion*. Sydney: CCH Australia.
- ICAO. (2001). *Annex 13 to the Convention on International Civil Aviation: Aircraft Accident and Incident Investigation* (9th ed.). (Including Amendment 11 and supplement, Nov. 23, 2006).
- ICAO (2003). *Manual of Aircraft Accident and Incident Investigation: Part IV—Reporting*. Doc. 9786 (1st ed.).
- ICAO (2008). Accident Investigation and Prevention (AIG) Divisional Meeting Working Paper 8: Conclusions in final reports.
- NASA. (2006). *NASA Procedural Requirements for Mishap and Close Call Reporting, Investigating, and Recordkeeping*. NPR9621.1B.
- Redmayne, M. (1999). Standards of proof in civil litigation. *The Modern Law Review*, 62, 167-195.
- Rimson, I. (1998). *Investigating “Causes.”* Paper presented at the 29th Annual Seminar of the International Society of Air Safety Investigators Annual Symposium, Barcelona, October 1998.
- Stapleton, J. (2001). Unpacking causation. In P. Cane & J. Gardner (Eds.), *Relating to Responsibility* (pp. 145-185). Oxford, UK: Hart Publishing.
- Stapleton, J. (2002). Scientific and legal approaches to causation. In I. Freckelton & D. Mendelson (Eds.), *Causation in Law and Medicine* (pp. 14-37). Aldershot, UK: Ashgate.
- USAF (1999). *Safety Investigations and Reports*. Air Force Instruction 91-204. (Chapter 5)
- U.S. Department of Energy (1997). *Implementation Guide for Use with DOE Order 225.1A, Accident investigations*.
- Walker, M.B. (2007). Improving the Quality of Investigation Analysis. *ISASI Forum*, January-March 2007.
- Walker, M.B., & Bills, K.M. (2008). *Analysis, Causality, and Proof in Safety Investigations*. ATSB Aviation Research and Analysis Report AR-2007-053. Canberra, Australia: Australian Transport Safety Bureau.
- Wood, R.H., & Sweginnis, R.W. (2006). *Aircraft Accident Investigation* (2nd ed.). Casper, WY: Endeavor Books. (Chapter 1.)
- Wright, R. W. (1988). Causation, Responsibility, Risk, Probability, Naked Statistics, and Proof: Pruning the Bramble Bush by Clarifying the Concepts. *Iowa Law Review*, 73, 1001-1077.

# Approaches to Accident Investigation by Investigators from Different Cultures

By Wen-Chin Li, Hong-Tsu Young, Thomas Wang, and Don Harris



**Dr. Wen-Chin Li** is an assistant professor at the National Defense University, Republic of China, and a Visiting Fellow in the Department of Systems Engineering and Human Factors, Cranfield University, United Kingdom. He is an aviation human factors specialist of the European Association of Aviation Psychology and a registered member of the Ergonomics Society (MErgS). He and his following co-authors won the prize for the best paper of the 2007 ISASI seminar. Contact e-mail: [w.li.2002@cranfield.ac.uk](mailto:w.li.2002@cranfield.ac.uk).



**Professor Hong-Tsu Young** is the managing director of the Executive Yuan, Aviation Safety Council, Republic of China. He was the coordinator of the National Taiwan University Commercial Pilot Training Program by the Civil Aviation Authority (CAA), and deputy chairman of the Department of Mechanical Engineering, National Taiwan University.



**Thomas Wang** is currently the director of Flight Safety Division, Aviation Safety Council. He is a former China Airlines Airbus A300 pilot. Thomas joined ASC as an aviation safety investigator in 2000. He was the investigator-in-charge of the China Airlines CI611 accident investigation and the Singapore Airline SQ006 accident investigation Human Factors Group chairman.



**Dr. Don Harris** is director of Flight Deck Design and Aviation Safety Group at Cranfield University. He was an aircraft accident investigator (specializing in human factors) on call to the British Army Division of Army Aviation. Don is a Fellow of the Ergonomics Society, a Fellow of the Higher Education Academy, and a chartered psychologist. He is the author of more than 120 book chapters, journal and conference papers, and has edited or authored 13 books on the topics of cognitive ergonomics and human factors in aviation. He is also commissioning editor for the Ashgate series of research monographs Human Factors in Defense.

## Introduction

Cultural characteristics play a significant part in aviation (Helmreich & Merritt, 1998). The collective nature of Chinese society is consistent with its broad, contextual view of the world and the Chinese belief that events are highly complex and determined by many factors. On the other hand, the individualistic nature of Western

society is consistent with a focus on particular objects in isolation from their context and with Westerners' belief that they can know the rules governing objects and therefore can control that objects' behavior (Nisbett, 2003). Westerners have a strong interest in categorization, which helps them know what rules to apply to objects, and formal logic plays a major role in problem solving. The Chinese attend to objects within their broad context. The world seems more complex to the Chinese than to Westerners, and understanding events always requires consideration of many factors that operate in relation to one another in a complex manner. From the *I-Ching* (the ancient Chinese book of philosophy): "For misery, happiness is leaning against it; for happiness, misery is hiding in it. Who knows whether it is misery or happiness? There is no certainty. The righteous suddenly becomes the vicious; the good suddenly becomes the bad." Chinese are less concerned with finding the truth than with finding a harmonious way to live in the world. In part, the Chinese failure to develop science can be attributed to a lack of curiosity, but the absence of a concept of nature would also have served to inhibit the development of science (Nisbett, Peng, Choi, & Norenzayan, 2001). Kluckhohn (1951) proposed one well-known definition for culture: "Culture consists in patterned ways of thinking, feeling, and reacting, acquired and transmitted mainly by symbols, constituting the distinctive achievements of human groups, including their embodiments in artifacts; the essential core of culture consists of traditional ideas and especially their attached values." If the majority of people in a society have the same way of doing things, it becomes a constituent component of that culture (Jing, Lu, & Peng, 2001). A culture is formed by its environment and evolves in response to changes in that environment, therefore, culture and context are really inseparable (Merritt & Maurino, 2004).

Commercial aviation accident rates differ among global regions (CAA, 1998). Asia has a higher accident rate (5.1 and 8.0 accidents/million departures) than either America or Europe (1-1.5 accidents/million departures). The underlying causal factors also show differences between the regions. In Asia, failures in crew resource management (CRM) are the most frequent circumstantial factor in accidents. An analysis of accidents involving aircraft from Asia (Taiwan) by Li, Harris & Yu (2008) using the Human Factors Analysis and Classification System (Wiegmann & Shappell, 2003) found that poor CRM was related to subsequent errors in decision-making, perceptual errors and violations in procedures. These subsequent error categories showed a thirty-to fortyfold increase in their likelihood of occurrence in the presence of poor CRM (Li & Harris, 2006).

Regional differences of accident rates have a major impact on CRM implementation and crew performance. There is a differ-

ence in how CRM training is perceived across the world. In the U.S., CRM is normally seen as the primary vehicle to address human factors issues. Other countries perceive human factors and CRM as overlapping concepts, viewing them as close but distinct relatives (Johnston, 1993). However, cultural issues in aviation operations run deeper than simply issues in CRM. They pervade all aspects of operations (including standard operating procedures) and ultimately stem from issues in design (Harris & Li, 2008). For example, Westerners tend to adopt a function-oriented model (where stimuli are grouped in terms of their purpose) connected to a task-oriented operating concept (where specific actions are performed to achieve well-defined results) resulting in a preference for a sequential approach to undertaking tasks (inherent in checklists and SOPs). The Asian preference is for an integrated, thematic approach (where stimuli are grouped in terms of common, generic interrelationships); hence a task-oriented operating concept contradicts their preferred method of working (Rau, Choong, & Salvendy, 2004). There are also fundamental differences in the mental models of people in these cultures. As mentioned previously, Westerners have a strong interest in categorization, which helps them know what rules to apply to the objects.

In contrast, the Chinese believe in constantly changing circumstances; they pay attention to a wide range of events and search for relationships between things. The Chinese think you can't understand the part without understanding the whole. In contrast, Westerners apply a logical and scientific approach and occupy a simpler, more deterministic world. Westerners focus on salient objects instead of the larger picture, and they think they can control events because they know the rules that govern the behavior of objects. The Chinese are disinclined to use precisely defined terms or categories in many areas but instead use expressive, metaphoric language, e.g., "painting a dragon and dotting its eyes" (means hit the point) (Nisbett, 2003). From the *Tao Tè Ching*, "The heavy is the root of the light; the unmoved is the source of all movement; to shrink something, you need to expand it first; to weaken something, you need to strengthen it first; to abolish something, you need to flourish first." The dialectical thought of the Chinese Yin-Yang principle is in some ways the opposite of Western-style logical thought. It seeks not to decontextualize but to see things in their appropriate contexts. Chinese believe what seems to be true may be the opposite of what it seems to be. However, from a Western viewpoint, the Chinese seem to not only lack logic but to even deliberately apply principles of contradiction.

There is an interesting issue that results from these differences between cultures and regions. Culture is not just about the superficial, observable differences between countries, their food, their style of clothes, and even their languages. There are some fundamental cognitive differences in reasoning, organization of knowledge, structures of causal inference, and attention and perception between Eastern and Western cultures (Nisbett, 2003). These issues manifest themselves in the following manner. Westerners are likely to overlook the influence of the wider context on the behavior of objects and even of people. However, Asian cultures are more susceptible to 'hindsight bias'. Westerners are more likely to apply formal logic when reasoning about events but Easterners are more willing to entertain apparently contradictory propositions. The aim of this research is to establish if the different cognitive styles of European and Chinese accident investigators have an effect on the conclusions drawn when conducting an accident investigation.

## Method

### *Participants*

The participants in the study were 16 Chinese (Taiwanese) accident investigators and 16 British accident investigators. As far as was possible, the participants were matched for experience. They had a background as pilots, air traffic controllers, airline safety officers, and maintenance staff.

### *Data*

The research data were based on the narrative descriptions from the Ueberlingen accident report (BFU: AX001-1-2/02) occurring on July 1, 2002.

### *Analytical tool*

The Human Factors Analysis and Classification System (HFACS, Wiegmann & Shappell, 2003) was used as a basis upon which to classify the factors in the accident. HFACS is based upon Reason's (1990) model of human error in which active failures are associated with the performance of front-line operators in complex systems. Latent failures are characterized as inadequacies or mis-specifications that lie dormant within a system for a long time and are only triggered when combined with other factors to breach the system's defenses. The first (operational) level of HFACS classifies events under the general heading of "unsafe acts of operators." The second level of HFACS concerns "preconditions for unsafe acts." The third level is "unsafe supervision," and the fourth (and highest) organizational level of HFACS is "organizational influences."

### *Research design*

All participants were trained for 2 hours by an aviation human factors specialist in the use of the HFACS. This was followed by a debriefing session then a summary of the events in the Ueberlingen mid-air-crash was presented. All the participants then received a blank form to code their HFACS data to classify the contributing factors underlying this accident. This study used the version of the HFACS framework described in Wiegmann & Shappell (2003). The presence (coded 1) or absence (coded 0) of accident factors falling within each HFACS category was assessed by the investigators. To avoid over representation from any single accident, each HFACS category was counted a maximum of only once per accident. Thus, this count acted simply as an indicator of presence or absence of each of the 18 categories in the Ueberlingen accident.

Differences in the frequency of use of each HFACS category by Chinese and British investigators were examined using a chi-square ( $\chi^2$ ) test of association. Further analyses examining the association between the categories in higher and lower levels of the HFACS framework were also performed. As there is no identifiable dependent or independent variable in a  $\chi^2$  test of association, these analyses were supplemented with further analyses using Guttman and Kruskal's tau ( $\tau$ ), which was used to calculate the proportional reduction in error (PRE)—see Li & Harris (2006) and Li, Harris, & Yu (2008).

## Results and discussion

The results of frequencies and percentages of HFACS categories used by Chinese and British investigators when analyzing the Ueberlingen accident are shown in Table 1. In general, there were few significant difference in the frequency of use of the



HFACS Category		United Kingdom N=16		Taiwan N=16		Chi Square df = 1	
		Frequency	Percentage	Frequency	Percentage	Value	p
Level-4 Organizational Influences	Organizational process	15	93.8	11	68.8	3.29	<0.10
	Organizational climate	12	75.0	8	50.0	2.13	N/S
	Resource management	13	81.3	10	62.5	1.39	N/S
Level-3 Unsafe Supervision	Supervisory violation	12	75.0	12	75.0	0.00	N/S
	Failed to correct a known problem	10	62.5	13	81.3	1.39	N/S
	Planned inadequate operations	12	75.0	9	56.3	1.24	N/S
Level-2 Preconditions for Unsafe Acts	Inadequate supervision	12	75.0	8	50.0	2.13	N/S
	Technology environment	11	68.8	14	87.5	1.64	N/S
	Physical environment	5	31.3	5	31.3	0.00	N/S
	Personal readiness	5	31.3	8	50.0	1.16	N/S
	Crew resource management	15	93.8	15	93.8	0.00	N/S
	Physical/mental limitation	10	62.5	9	56.3	0.13	N/S
	Adverse physiological states	2	12.5	1	6.3	0.36	N/S
Level-1 Unsafe Acts of Operators	Adverse mental states	15	93.8	6	37.5	11.22	<0.001
	Violations	13	81.3	11	68.8	0.67	N/S
	Perceptual errors	5	31.3	11	68.8	4.50	<0.05
	Skilled-based errors	14	87.5	11	68.8	1.64	N/S
	Decision errors	15	93.8	15	93.8	0.00	N/S

**Table 1. Frequency and Percentage Counts of Causal Factors Deemed as Being Present in the Ueberlingen Accident in the HFACS Framework Broken Down by Eastern and Western Investigators**

Data from Eastern Participants (Taiwan)	Pearson Chi-square test			Goodman & Kruskal Tau		Odds ratio
	Value	df	P	Value	p	
Organizational process * Inadequate Supervision	7.27	1	.002	.46	.009	NS
Organizational climate * Supervisory violation	5.33	1	.021	.33	.025	NS
Organizational climate * Planned inadequate operations	6.35	1	.012	.40	.015	21.00
Organizational climate * Inadequate Supervision	16.00	1	.000	1.00	.000	NS
Resource Management * Inadequate Supervision	9.60	1	.002	.60	.003	NS
Supervisory violation * Personal readiness	5.33	1	.021	.33	.025	NS
Planned inadequate operations * Personal readiness	6.40	1	.012	.40	.015	21.00
Inadequate Supervision * Physical environment	7.27	1	.007	.46	.009	NS
Inadequate Supervision * Personal readiness	9.00	1	.003	.56	.004	49.00
Inadequate Supervision * Physical/mental limitation	6.35	1	.012	.40	.015	21.00
Technology environment * Perceptual errors	5.03	1	.025	.31	.030	NS
Technology environment * Decision errors	7.74	1	.006	.47	.008	NS
Personal readiness * Perceptual errors	7.27	1	.007	.46	.009	NS
Physical/mental limitation * Skill-based errors	3.88	1	.049	.24	.050	10.667

**Table 2. Chi-square Test of Association, Goodman and Kruskal's Tau And Odds Ratios Summarizing Significant Associations Between Categories of HFACS Framework for Chinese Investigators**

HFACS categories between British and Chinese accident investigators. The only significant differences were related to the frequency of use of the categories concerned with “adverse mental state” (HFACS Level-2) and “perceptual error” (Level-1). As has been noted previously (Li, Young, Wang, & Harris, 2007) UK investigators were more likely to attribute “adverse mental state” as a psychological precursor to the accident and the Taiwanese participants were more predisposed to attributing the accident to a “perceptual error.” This may reflect reluctance on the part of Eastern participants to utilize the category of “adverse mental state” as it possibly has a degree of stigma attached to it. Instead, Chinese investigators may have opted to use the less blameworthy category of “perceptual error.”

However, there are interesting findings with regard to the different patterns of causality between the different levels of the HFACS analyses between the Chinese investigators and British investigators. Using the analytical methodology described in Li & Harris (2006) and Li, Harris & Yu (2008) to analyze the relationships between HFACS categories, the data sets from the Chinese and British investigators were analyzed separately. The results of the Chi-square, Goodman and Kruskal's tau and odds ratios for the Chinese investigators are given in Table 2; the results for the British investigators are given in Table 3. These results are also depicted graphically in Figures 1 and 2, respectively.

What is noticeable is that there are differences in the pattern of results described by Goodman and Kruskal's tau between the investigators from Britain and China. Goodman and Kruskal's tau has the advantage of being a directional statistic. In the analyses described in Tables II and III (and Figures 1 and 2), the lower-level categories in the HFACS were designated as being dependent upon prior actions in the categories at the immediately higher level in the framework, which is congruent with the theoretical assumptions underlying HFACS. The value for tau in these tables indicates the strength of the relationship, with the higher levels in the HFACS being deemed to influence (cause) changes at the lower organizational levels, thus going beyond what may be deemed a simple test of co-occurrence between categories, which is the basis of the simple  $\chi^2$  test of association.

There were 14 pairs of HFACS categories in adjacent organizational levels that had significant associations between causal factors in the Ueberlingen accident based on the analysis provided

by Chinese investigators. Further examination of Goodman and Kruskal's tau showed five significant associations between categories at Level-4 and Level-3, five significant associations between categories at Level-3 and Level-2, and four significant associations between categories at Level-2 and Level-1 (see Figure 1). There are also five pairs of associations between categories that had a high odds ratio. These suggested that “poor operational practices” were more than 21 times more likely to occur when associated with poor higher levels of “organizational climate.” For the Chinese investigators, the highest odds ratio was for “personal readiness,” which was 49 times more likely to occur in the accident sequence when associated with “inadequate supervision” (see Table 2).

Data from Western Participants (United Kingdom)	Pearson Chi-square test			Goodman & Kruskal Tau		Odds ratio
	Value	df	P	Value	p	
Planned inappropriate operations * Technology environment	4.75	1	.029	.30	.025	15.00
Personal readiness * Skill-based errors	5.03	1	.025	.31	.030	NC
Adverse physiological states * Perceptual errors	5.03	1	.025	.31	.030	NC
Adverse mental states * Decision errors	16.00	1	.000	1.00	.000	NC
Adverse mental states * Violations	4.62	1	.032	.29	.037	NC

NC: Not computed due to a zero frequency in one cell of the contingency table

**Table 3. Chi-square Test of Association, Goodman and Kruskal's Tau and Odds ratios Summarizing Significant Associations Between Categories of HFACS Framework for British Investigators**

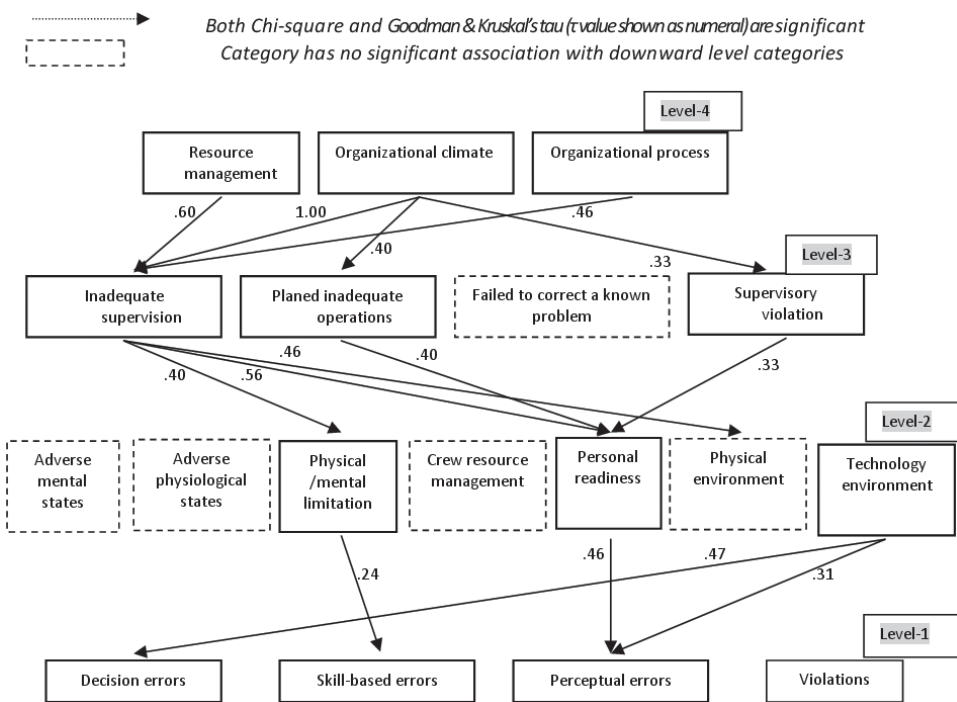

**Figure 1. Significant association of causal factors for the Ueberlingen accident at the four levels of the HFACS framework as categorized by Eastern (Taiwanese) aircraft accident investigators.**

There were five pairs of HFACS categories in adjacent organizational levels that had significant associations between causal factors in the Ueberlingen accident based upon the data provided by British investigators. There were no significant associations of categories between HFACS Level-4 and Level-3, one significant association between categories at Level-3 and Level-2, and four significant associations between categories at Level-2 and Level-1 (see Figure 2). Furthermore, from the analyses performed by the British investigators, there was only one pair of association between categories that had a high odds ratio. This suggested that the problem of “technology environment” more than 15 times more likely to occur when associated with “planned inadequate operations” (see Table 3).

This pattern of associations described diagrammatically in Figures 1 and 2 may reflect the different cognitive styles of Eastern and Western accident investigators, who are in turn products of their respective cultures. For Eastern investigators, many categories were associated with each other reflecting a predisposition

for a holistic understanding of the events in their wider context. However, the British (Western) accident investigators preferred patterns of explanation that ultimately lead directly to the accident event. Focus was on specific objects (categories). The decontextualization and object emphasis favored by Westerners and the integration and focus on many complex relationships by Easterners resulted in very different ways of making inferences about the accident, as was evident in the patterns of associations depicted in Figures 1 and 2. These may reflect the fundamental differences between Chinese and Western minds. In terms of patterns of attention and perception, Eastern cultures attend more to the environment; people from Western cultures attend more to objects (Nisbett, 2003). In science and technology, Western truth stimulated analytic thinking, whereas Eastern virtue led to synthetic thinking (Hofstede, 2001). Through these different logics, Eastern and Western people followed different paths in developing government and in developing their respective science and technology. This analysis further demonstrates that people from different cultures differ in cognition in ways that result in different perceptions, judgments, and decisions concerning the factors at play in the sequence of events in an accident.

As a result, it is argued that Chinese investigators will be predisposed to approaching accident investigation in a holistic manner, attempting to understand the complex relationship of causal factors leading to an accident. The Chinese conviction about the fundamental relatedness of all things made it obvious to them that objects are altered by context. Trying to categorize objects with exactness would not have seemed to be of much help in comprehending events. The world was simply too complex for categories for understanding objects or controlling them. The Chinese might be right about the importance of the field to understanding the behavior of the object and they might be right about complexity, but their lack of interest in categories prevented them from discovering laws that really were capable of explaining classes of events. As Nakamura (2003) noted that the Chinese advances reflected a genius for practicality, not a penchant for scientific theory and investigation. The process of accident investigation is almost akin to a Western notion of art. British (Western) investigators are more predisposed to approaching accident investigation (and human behavior) using rules of logic. Accident investigation is almost a scientific process.

When Western engineers develop flight operation systems,

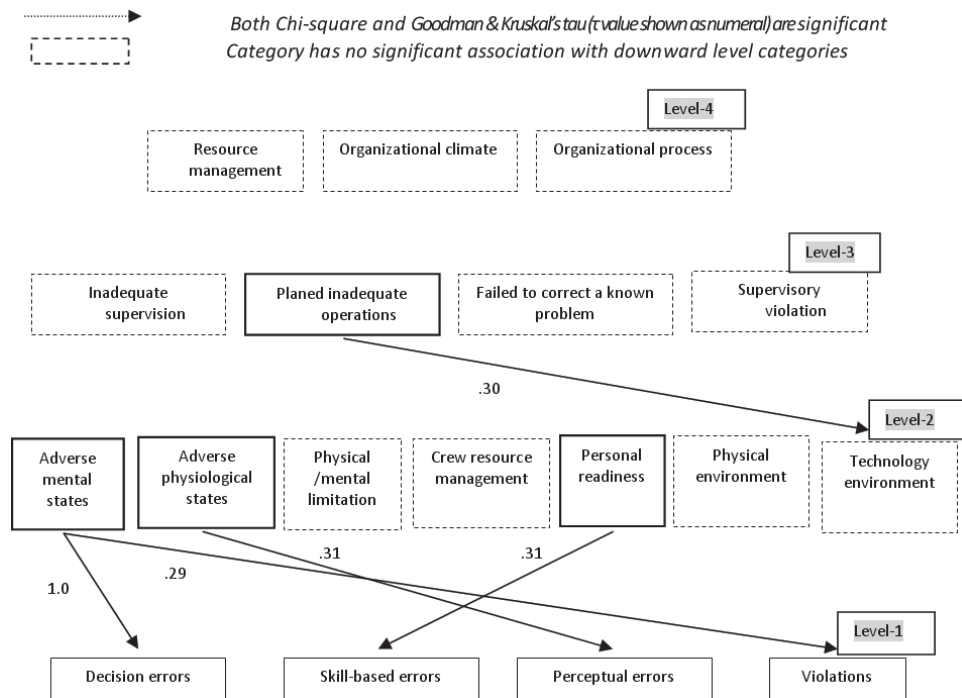

**Figure 2.** Significant association of causal factors for the Ueberlingen accident at the HFACS framework as categorized by Western (British) aircraft accident investigators.

training manuals, and standard operation procedures, they integrate their own vision of the world, which itself is heavily influenced by their cultural norms. They implicitly assume that all users around the world share their reasoning and values. Klein (2004) observed that people from different nations differ in their cognition in ways that result in dissimilar perceptions, judgments, and decision-making. National culture provides a fundamental basis for a group member's behavior, social roles, and cognitive processes. A frequently used example is that Western copilots (British) from a low power distance culture are more likely to question the actions of their captains. However, copilots from Eastern (China) high power distance countries dare not to speak out when their opinions may contradict their captain.

According to Hofstede's (1984 & 1991) classification of national culture, the working environments of Taiwan prefer tall organizational pyramids with centralized decision structures and have a large proportion of supervisory personnel. In these cultures, subordinates expect to be told what to do. However, members of these cultures frequently experience role ambiguity and overload. In general, group decisions are preferred but information is constrained and controlled by the hierarchy and there is resistance to change. On the other hand, the working environment of the UK exhibits low power-distance and is a culture high on individualism. Flat organizational structures are preferred with a relatively small proportion of supervisory personnel. Subordinates expect to be consulted. Self-orientation and identity is based on the individual, and individual decisions are regarded as being superior (Li & Harris, 2007).

The design of the aircraft, the management procedures, and the nature of safety regulation all have a strong Western influence. So it is not too surprising that a Western country comes out better aviation safety records when using the HFACS to analyze the underlying causes of accidents. However, it could even be

argued that the accident analysis system itself has an implicit cultural bias within it. The way Chinese investigators and British investigators attribute the causal factors at play in the same accident seems to be completely different. A simple frequency count of the categories used by accident investigators would seem to suggest that there is no difference between investigators from the two cultures. However, when the underlying causality between categories at different levels of HFACS is analyzed, a completely different pattern emerges between Eastern and Western investigators. It is difficult to say that either of these views is either right or wrong. You may only conclude that they are different. Global aviation is strongly influenced by Western mindsets; however, the challenge for safety is not to ignore these cross-cultural issues influencing safety but to manage the potential risks they may present. The ultimate purpose of accident investigation is to find the best approach for accident prevention

strategies around the world. This may require local, culturally congruent solutions, not the universal solutions currently being pursued in many cases.

## Conclusion

Separating the people from the problem assumes an individualist value set underlying the Western approach to investigation. In collectivist cultures, where relationships prevail over tasks, this is an almost impossible demand. Effective investigation for aviation accidents within different cultural contexts demands insight into the range of cultural values to be expected among partners from other countries, in addition to an awareness of the investigator's own culturally determined values. Effective international investigations also demand language and communication skills to guarantee that the messages sent to the other professional investigators from different cultures with different approaches to accident investigation will be understood in the way they were meant to be. The global interaction between different cultures involves sharing the values of all partners. It is important to know more about the similarities and differences in culture-influenced accident investigation philosophies, e.g., when European and Asian culture collaborate together. The cognitive orientation and mechanisms of Eastern and Western cultures are sufficiently different that they may draw completely different inferences from the same set of data (as in this case), especially in the case where human factors are concerned. The best approach may be to try to understand the events in the accident from the viewpoint of the culture of the pilots/airline involved in the accident and not from the cultural viewpoint of the investigator. This way there might be a better chance that culturally congruent remedial actions can be proposed. However, by better understanding these cultural differences it seems highly likely that they can only serve to comple-



ment and enrich each other. There is no one “objective” truth to any accident investigation. Whether we realize it or not, all conclusions draw (and the process by which we reach them) are deeply influenced by our culture. ♦

## References

- CAA (1998). *CAP 681 Global Fatal Accident Review 1980-1996*. London, UK: Civil Aviation Authority.
- Harris, D. & Li, W-C. (2008). Cockpit Design and Cross-Cultural Issues Underlying Failures in Crew Resource Management. *Aviation Space and Environmental Medicine*, 79(5), 537-538.
- Helmreich, R.L. & Merritt, A.C. (1998). *Culture at Work in Aviation and Medicine*. Aldershot: Ashgate, 1998.
- Hofstede, G. (1984). *Culture's Consequences: International Differences in Work-Related Values*. Beverly Hills: Sage Publications.
- Hofstede, G. (1991). *Cultures and Organizations: Software of the Mind*. London: McGraw-Hill Book Company.
- Hofstede, G. (2001). *Culture's Consequences: Comparing Values, Behaviors, Institutions, and Organizations Across Nations*. California: Sage Publications.
- Jing, H.S., Lu, C.J. & Peng, S.J. (2001). Culture, Authoritarianism and Commercial Aircraft Accidents. *Human Factors and Aerospace Safety*, 1, 341-359.
- Johnston, N. (1993). CRM: Cross-Cultural Perspectives. E. L. Wiener, B.G. Kanki, & R.L. Helmreich (Editor), *Cockpit Resource Management* (pp. 367-398). San Diego: Academic Press.
- Klein, H.A. (2004). “Cognition in Natural Settings: The Cultural Lens Model,” in Kaplan, M. (Editor), *Cultural Ergonomics*, Elsevier, San Diego, 249-280.
- Kluckhohn C. (1951). “*The Study of Culture*.” Lerner D., Lasswell H.D., Editor. The Policy Sciences. Stanford, CA: Stanford University Press, 86-101.
- Li, W-C. & Harris, D. (2006). Pilot Error and Its Relationship with Higher Organizational Levels: HFACS analysis of 523 accidents. *Aviation, Space and Environmental Medicine*, 77(10), 1056-1061.
- Li, W-C., Harris, D. & Chen, A. (2007). Eastern Minds in Western Cockpits: Meta-analysis of Human Factors in Mishaps from Three Nations. *Aviation Space and Environmental Medicine*, 78 (4), 420-425.
- Li, W-C., Harris, D. & Yu, C-S. (2008). Routes to Failure: Analysis of 41 Civil Aviation Accidents from the Republic of China using the Human Factors Analysis and Classification System. *Accident Analysis and Prevention*, 40(2) 426-434.
- Li, W-C., Young, H-T, Wang, T. & Harris, D. (2007). International Cooperation and Challenges: Understanding Cross-cultural Issues in the Processes of Accident Investigation. *ISASI Forum*, 40(4), 16-21.
- Merritt, A. & Maurino, D. (2004). Cross-Cultural Factors in Aviation Safety. In, M. Kaplan (Ed) *Advances in Human Performance and Cognitive Engineering Research*. San Diego, CA; Elsevier Science, 147-181.
- Nakamura, H. (2003). *Ways of Thinking of Eastern Peoples: India, China, Tibet, Japan*. London: Trubner & Corporation.
- Nisbett R.E. (2003). *The Geography of Thought: How Asians and Westerners Think Differently and Why*. New York: The Free Press.
- Nisbett R.E., Peng, K., Choi, I. & Norenzayan, A. (2001). *Culture and Systems of Thought: Holistic vs Analytic Cognition*. *Psychological Review*, 108, 291-310.
- Rau, P-LP, Choong, Y-Y & Salvendy G. (2004). A Cross-cultural Study on Knowledge Representation and Structure in Human Computer Interfaces. *International Journal of Industrial Ergonomics*, 34, 117-129.
- Wiegmann, D.A. & Shappell, S.A. (2003). *A Human Error Approach to Aviation Accident Analysis: The Human Factors Analysis and Classification System*, Ashgate, Aldershot, England.

# International Support for Aircraft Accident Investigation and Proposal to Enhance Aviation Safety in States Where It Is in the Developing Stage

By Syed Naseem Ahmed, Technical Investigator, Safety and Investigation Board, Civil Aviation Authority, Pakistan



*Syed Naseem Ahmed was commissioned in the Pakistan Air Force in 1976 as a maintenance engineer (aerospace). From then until 1982, he served at the 1st and 2nd overhaul maintenance levels and was an instructor at the Institute of Air Safety from 1982 to 1988. He was a member of the Aircraft Accident Investigation Board from 1988-1990 and graduated from the Air War College in 1992. He has investigated more than 20 major aircraft accidents. In 2000, he joined the Pakistan CAA as a senior airworthiness surveyor and since 2004 has worked at the Safety and Investigation Board as a technical investigator. Recently, Syed Naseem Ahmed has been instrumental in bringing a number of ISASI Reachout workshops to Pakistan.*

ISASI president and ladies and gentlemen—good morning and asslam-u-alekum. It is indeed a pleasure for me to speak before this gathering of highly educated and experienced people from the aviation world. I am grateful to ISASI for that. I have been associated with safety education and aircraft accident investigation since 1978. My first investigation assignment was in 1978 to investigate an inflight wing separation of a sabre fighter of PAF. At that time, I did not have the slightest idea of investigations. It appeared to me a complicated process based on scientific principles. I could not think of applying any ideas or personnel skills while conducting investigations. But today, after conducting more than 30 major aircraft accidents and around 200 incidents investigations, I have begun to see the art of applying this science—maybe to exploit science for one's interests in the investigation. Whether it is an art, science, or a combination, I really admire the intellectuals who selected the theme for this year ISASI seminar as "Investigation: The Art and the Science."

I will take you through some investigation experiences that contributed to understanding the process; and based on that, I will share a few lessons learned to ensure optimum international support in investigations.

Let me refer to the investigations of two fatal accidents in Pakistan—first the investigation into a Cessna 402B, which crashed in the Arabian Sea, in 2003 and second, the investigation into the Fokker F-27, which crashed just after takeoff near Multan airfield, killing all 45 persons that were on board, including the crew. These two accounts are useful for those states where accident investigation is still in the developing stage. In the end, based on my evaluation of the status of aviation safety through

investigations, I will make some suggestions to the stakeholders for enhancing the aviation safety in south Asia.

The first investigation is that of a Cessna 402B, which took off from Karachi at 0811 hrs on November 2003 and was missing from radar after 8 minutes of flying. The wreckage was located by Pakistan Navy search and rescue team, within 2 hrs. All bodies on board, except one of a Chinese minister, were recovered. The aircraft wreckage was recovered after 17 days of underwater search. It was reconstructed in a hangar. The only conclusion from the wreckage analysis was that the tail section had separated in the air, a case of inflight structural failure. The manufacturer, after receiving the notification, had sent a carton full of operational and maintenance manuals. I did not get any other help from the manufacturer. The investigation continued for 6 months, and due to pressure from the government we were going to finalize the report as cause undetermined—with an observation that the manufacturer did not provide any help, other than a carton of literature. However, I was still in search of some answers and therefore started reading the operational and technical manuals provided by the manufacturer. And then to my luck, I found a clue. I learned that the Cessna Corporation had conducted research in 1988 on the structural integrity of one of its most stressed aircraft. The research found that certain structural components in tail section were subject to high fatigue and had lost material strength. Cessna, through special inspection documents (SIDs), had asked the operators to conduct special inspections to detect cracks. However, these SIDs were not received by the operator. The operator was still using manuals issued in 1982. Hence, the SIDs were not complied with and the tail section continued to deteriorate and ultimately failed during the eventful flight.

The second accident took place on July 10, 2006, when a PIA F-27 Fokker, registration No. AP-BAL, was on flight from Multan to Lahore. The aircraft had 45 souls on board, including 4 crewmembers. The aircraft took off for Lahore at 1205 hrs Pakistan Standard Time (PST) from Multan Runway 36. Soon after takeoff, the aircraft was observed by ATC and other eyewitnesses to be maintaining very low altitude and drifting right in a bank. The control tower tried to establish contact with the aircraft, but no contact was established. Subsequently, a call from a local resident was received stating that an aircraft had crashed at about 2 km northeast of the runway. All souls on board the aircraft had fatal injuries, and the aircraft was completely burned.

The crash shocked the whole nation. The tragic death of all

passengers and crew at the crash site by ground fire not only ignited the passions of public against the operator and regulator but also strengthened their ill-conceived ideas and perceptions regarding the deteriorated condition of the aging Fokker fleet. This aircraft was manufactured in 1964 and had completed 84,000 hrs. Hence the news media, general public, and even the few aviation experts, including pilots, hurriedly concluded that the crash was due to the old age of the aircraft. The heated debates at various levels and news media reporting influenced the cabinet to ground the Fokker fleet in the public interest. The grounding, in fact, caused more inconvenience to the general public as there was no alternate aircraft to connect remote locations served by Fokker. This was the unfortunate and non-ceremonial exit for an aircraft such as the Fokker, which had served the nation for decades with ease of operation and economy.

The investigators were faced with a challenging task to investigate the causes and convince the affected parties accordingly. While the investigation was at the initial stage, a number of lawyers associations issued legal notices to the regulator and the operator. The director general of the CAA, realizing the importance of this particular investigation and expected critical scrutiny of the investigation report at the national as well as international levels, made arrangements to ensure participation from international investigation organizations. PCAA notified the UK AAIB, the FAA, and the BEA France, in addition to the manufacturer of the aircraft and engine, i.e., Rolls-Royce and Fokker Services. This resulted in the available services of the Accident Investigation Branch (AAIB) UK, the BEA of France, the DSB of the Netherlands, the FAA, Stork Fokker Services B.V. Netherlands, and the FBA of Germany. The UK AAIB also coordinated with Dowty Propellers and Goodrich Engine Control Systems for investigation support to PCAA.

### Report writing

Under normal circumstances in such cases where the aircraft appeared to have stalled after initial climb, failed to recover, and caught fire after impact, the investigations would have been easily written only in technical language. However, under these difficult conditions, where aviators as well as non-aviators from the general public, the news media, public representatives, honorable lawyers, and judges were involved in the proceedings of

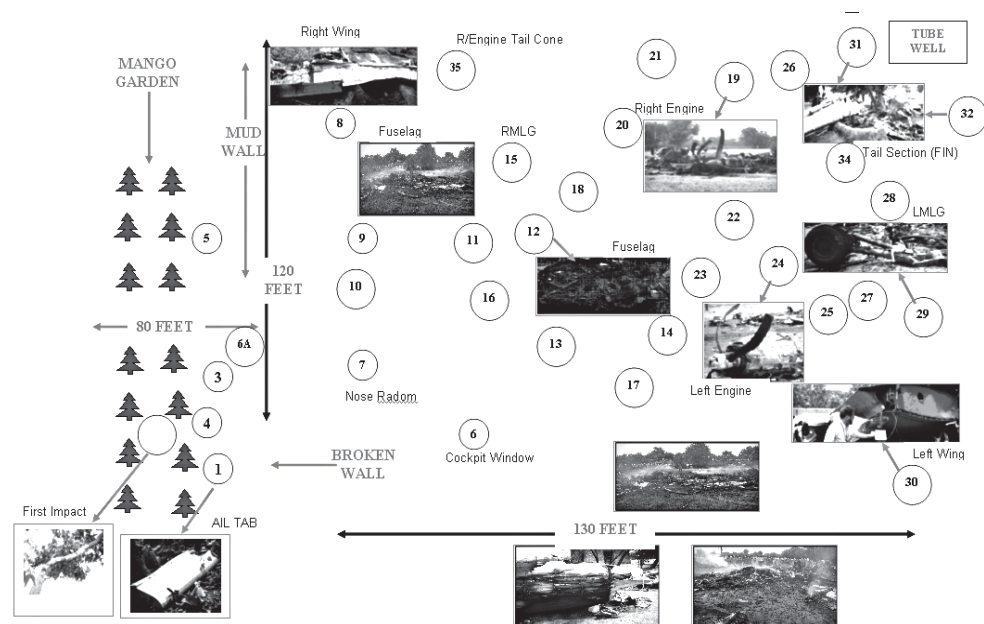

INDEX OF AIRCRAFT PARTS AS SHOWN IN WRECKAGE DIAGRAM

- |   |   |
|---|---|
| <ol style="list-style-type: none"> <li>1. Outer most portion of right-hand wing and aileron</li> <li>2. Right-hand wing outer portion</li> <li>3. Right-hand aileron (along with tab)</li> <li>4. Inner portion of outer right-hand flap</li> <li>5. Outer portion of outer right-hand flap oxygen bottle</li> <li>6. Cockpit window</li> <li>6A. Upper portion right-hand landing gear along with ram (extended)</li> <li>7. Portion of nose radom</li> <li>8. Right wing outer portion (upside down)</li> <li>9. Right wing lower portion (along with flaps)</li> <li>10. Emergency fire extinguisher bottle (plug and pin intact)</li> <li>11. Oxygen bottle</li> <li>12. Fuselage (front portion)</li> <li>13. Cockpit</li> <li>14. Nose landing gear (ram extended)</li> <li>15. Right-hand landing gear (ram extended)</li> <li>16. Inverter</li> <li>17. Left-hand engine exhaust pipe</li> <li>18. Accessories gear box (right-hand)</li> </ol> | <ol style="list-style-type: none"> <li>19. Right-hand engine (S. No. 8273, feathered)</li> <li>20. Right-hand engine upper cowlings (all three sides intact)</li> <li>21. Right-hand engine fire extinguisher bottle</li> <li>22. Center wing upper portion</li> <li>23. Center wing along with right-hand inner flap</li> <li>24. Left-hand engine (unfeathered along with cowls [S. No. 13009])</li> <li>25. Aft cargo section (portion of fuselage)</li> <li>26. Center wing and right-hand wing inboard of engine</li> <li>27. Exhaust pipe right-hand engine</li> <li>28. Left-hand wing along with nacelle (with flap)</li> <li>29. Left-hand landing gear</li> <li>30. Left-hand wing outer portion upside down along with aileron</li> <li>31. Rudder + vertical fin</li> <li>32. Horizontal stabilizer (left-hand side along with elevator)</li> <li>33. Fuselage rear portion</li> <li>34. Horizontal stabilizer (right-hand)</li> <li>35. Right-hand engine tail cone</li> </ol> |
|---|---|

investigations, the obligation to explain all technical aspects in such a manner that these interested parties would face minimum difficulties in understanding the report was realized. I consulted the famous book on aircraft investigation by Barnes W. McCormick and M.P. Papadak, which proved extremely useful for report writing.

### Objectives

The technical investigation was focused to determine the following three primary questions:

1. Were the engines capable of producing required power and producing it at the time of impact?
2. Was the aircraft intact and its control surfaces operable without any difficulty till it departed from its intended flight path?
3. Was there any other cause of the accident, such as sabotage, fire, bird hit, or multiple system failures?

### Initial appraisal at the scene of accident

It is our common experience that the wreckage is extensively dis-



turbed and taken away by people in our region, thus making investigation a difficult task due the loss of vital evidence. The Fokker crash site and its wreckage were relatively easy to reach and to investigate with speed and certainty. The wreckage was not taken away by people and was confined to a mango farm on soft ground. A few small aircraft parts were found within the mango farm, and few trees were broken and affected by the heat. Some quantity of fuel had spilled/pooled in the farm. The aircraft entered the soft ground area from the mango farm through the mud wall, which was swept away by the aircraft body during final impact with the ground. The right wing was the first major part on the left side on the ground. The main fuselage was on the right, and the right engine was on the left. The next major part was the left engine, but it was on the right side followed by the main fuselage and tail section. The left wing was on the extreme right side of fuselage (see wreckage diagram above). The significant findings from the wreckage were

- The aircraft crashed as one piece. Only a few pieces of metallic debris from the engine fell on the runway.
- The flaps were found in zero position.
- The nose and main landing gears were found in extended position.
- There was no evidence of sabotage or inflight fire.
- There was no inflight structural failure.
- The right engine appeared to be at low RPMs.
- The left engine appeared to be rotating at high speed.

#### **Strip-up examination of engines at PIA Engineering in Karachi**

The strip examination revealed abnormal damage to the right engine turbine. Hence, it was considered crucial for the engine parts, rear bearing housing, plain bearing, main bearing, and turbines to be returned for laboratory analysis to determine the nature of fractures observed on the bearing.

#### **Investigation of engine fuel pumps and combined control units of both engines**

The high-pressure fuel pumps and pitch control units of both engines were sent to Goodrich Engine Control Systems Birmingham, UK. These were X-rayed, then given a test run in the presence of Anne Evans, the senior inspector from the UK AAIB; Mike Webber, a Rolls-Royce investigator; and Norman Widdop from Goodrich (X-ray picture). They concluded that these units were functioning properly at the time of the crash and would not have contributed to any restriction in engine performance.

#### **Propeller investigation by Dowty Propellers**

The propellers, pitch control units, and feathering pumps were returned to Dowty Propellers UK, which arranged the for the strip examination and test facilities of the feathering pumps and control units at Turner Aviation, Glasgow, with AAIB and Rolls-Royce representatives in attendance. They concluded that prior to the event, the propeller equipment was operating normally. At the point of impact, the left-hand propeller equipment was operating at takeoff power as designed and the right-hand propeller had feathered as intended in the event of low torque pressure. There were no untoward features found in the propeller equipment that would have contributed to the accident.

#### **CVR analysis by BEA France**

The CVR was found burned extensively; however with the help of Christophe Menez, the analysis was carried out in the presence of Michiel Schuurman, DSB; Wim Furster, DSB; Arther Reekers, Fokker Services; and Holger Litzenberg, Rolls-Royce Germany. Their conclusion was that after 29 mins 16 seconds of recording, an engine spool down, i.e., winding of revolutions, can be heard.

A spectrum analysis shows changes in the frequencies produced by the engine or its propeller. About 1 second after the beginning of the engine spool down, an electric interference was recorded on channel 3 of the CVR (dedicated to VHF communications and flight crew headsets). This electrical interference is visible for about 12.7 seconds, and its maximum frequency is around 945 Hz. After 29 mins 18.8 seconds of recording, i.e., about 2.8 seconds after the engine spool down, an alarm similar to the fire alarm was recorded on the CAM channel. It is visible on the spectrum analysis, and its fundamental frequency appears to be approximately 1500 Hz.

#### **FDR readout at BEA**

The FDR was badly burnt in the crash fire. Only the protected module was taken to BEA, where the original connector was cut and a dedicated connector was used to plug the card into an FDR chassis. The Honeywell ATU software was used to download the raw file from the memory. Nevertheless the software did not recognize the configuration of the memory card and could not retrieve any file but one containing only bits equal to zeros. The problem was reported to Honeywell, which advised us to use the CTS software developed in France for BEA. However, the results were the same. We decided to take the FDR memory card to the manufacturer in the U.S. BEA engineers took the card to the U.S. and were successful in downloading the data for PCAA.

#### **CVR analysis at UK Aircraft Accident Investigation Branch**

After successful downloading and limited analysis of the CVR data, the CVR was taken to the UK AAIB for detailed frequency analysis. The purpose was to independently determine again the engine and propeller RPMs with the help of recorded frequencies and to find out what the problem was with right engine and whether the left engine was producing the required power.

We tried to determine the RPMs of as many engine components as possible. For instance, if we could determine that the left engine was running at 15,000 RPMs at the time of impact, then we could say that the left engine was working as designed. Similarly, if we could determine that the propeller was rotating at 1,200 RPMs, we could say it was in accordance with requirements. Working on the same principle, if the RPMs of the feathering pump or fuel pump is known, then with the help of frequencies recorded during CVR operation, we could determine their operational status 30 minutes before the crash. The spectrum analyzer plots sound frequency vs. time with color as energy. Every time a blade rotates, it generates a pressure wave. If rotating at a constant speed, this will lead to the generation of pressure waves at a constant frequency. If we know the number of blades, we can analyze these frequencies to determine the RPMs of the spindle. With engine takeoff RPMs of 15,000 and feathering pump RPMs of 10,000, the pump frequencies are expected at around 166 Hz. However, the frequencies of Engine 1 throughout the accident

flight are not as clear as Engine 2, except after Engine 2's failure. We could see from Engine 1 is that the frequency increases at the same rate as Engine 2 but does not appear to exhibit the overshoot and hunting for maximum RPMs that Engine 2 does. Engine 2 has clear harmonics and it is 7th harmonic, which tells us that there was a drop in RPMs after takeoff power was selected.

### Behavior of feathering pumps

The first feathering pump frequency was recorded at 00:29:17, coinciding with the decay in Engine 2 propeller frequency. There are several discontinuities in the recording of the feathering pump frequencies, so it is not clear the duration that the pump is running. However, there are two distinct frequencies indicating when it was autofeathered and when it was operated by the aircrew.

### Fire bell

The BEA report identified the presence of a bell, which was heard by the investigating team, too. It sounded like a fire bell. Analysis of the cockpit area mike frequencies revealed a frequency around 1,500 Hz coinciding with the point of RPM decay of Engine 2 and runs continuously until the end of the recording. The design and operations principles of the fire bell were examined with the help of Fokker Services. We learned that the bell would ring only if there was any fire around the engine, enough to activate the circuit. However, there was no fire around the engine. The damage to the turbine blades was contained within the engine. Hence, the reason for the bell to "ring" could not be established.

### Analysis by Stork A.B. Services, the Netherlands

Fokker Services provided an analysis based on CVR and FDR data in the light of aircraft expected performance. The analysis confirmed the conclusions by the BEA and the UK AAIB regarding engine performance. It also analyzed the performance of the aircraft and aircrew actions with the help of airspeed, altitude, and heading data retrieved from the FDR. According to Fokker Services, the aircraft should reach screen height (35 feet) within 38 seconds. The take off roll until screen height took 45 seconds. The difference may be explained due to engine failure. The aircraft should obtain a climb gradient of 3.3% when an engine failure occurs at  $V_1$  under the prevailing conditions provided landing gears are retracted. With the landing gears out, the gradient angle is reduced to 1.7%. In this case, after lift off the crew did not sufficiently correct the heading and roll deviations. Some parts in the recording show that the crew was able to recover the heading and roll deviations momentarily. Therefore, we concluded that the aircraft was controllable at that moment.

### Engine investigation by Rolls-Royce, Bristol, UK

Rolls-Royce analysis conclude that the plain location bearing was under some distressed condition at the time of last assembly as a sequence of events leading up to the final rundown had originated in the area of the rear turbine location bearing. The sequence led to final failure is as follows:

- (a) Laboratory examination revealed that two of the bolts retaining the rear turbine location bearing had fractured as a result of reverse bending fatigue development.
- (b) A third bolt had cracked also as a result of the same mechanism. It was determined that distress to the inner track of the location bearing resulted in a cyclic load acting on the bearing

outer track retaining assembly, resulting in the cyclic loading and fatigue fracture of these bolts.

(c) Examination of the rear location bearing revealed that it had sustained inner track distress and the clamping load on the bearing assembly had been lost.

(d) Due to the extensive damage to the inner track, it was not possible to conclusively identify the primary cause of the bearing distress; however it had initiated some time before the subject flight.

(e) Loss of clamping load and subsequent axial displacement of the bearing assembly led to axial movement of the turbine rotor assembly. This axial displacement resulted in rubbing contact between the rear of the HPT blade/disc roots with the front inner platforms of the IPT NGVs leading to localized overheating of the blade root neck sections, the loss of mechanical properties, and the subsequent blade release. A similar rub occurred between the IPT rotor and the LPT NGVs with one IPT blade fracturing in fatigue as a result of excitation due to the axial rub.

(e) The reason for the final rundown of the engine is considered to be the result of the release of the HPT and IPT rotor blades, leading to a significant loss of engine performance, combined with loss of axial and radial location of the rotor causing considerable mechanical distress and resistance to rotation.

### Lessons learned

Let me summarize the lessons learned. The first lesson is to issue a prompt notification as per Annex 13 and send it to as many organizations as you may think. It will bring a lot of information and organizational support to your doorsteps. As you proceed, analyze critically the requirements and pay special attention to your expectations from international organizations, which means prepare well and plan well. In the process, keep examining your needs—keeping in view the obligations in Annex 13. It will help you maintain good relations with international investigation organizations. Most importantly, do not hesitate to explain your position and difficulties, such as administrative, financial, and traveling—including visa difficulties. Keep all the stake holders in the loop while communicating with one agency. Wherever required, delegate investigation activities to other experts as we did with the FDR and engines. BEA took the FDR to the U.S. and was successful in downloading it, whereas it was difficult for us due to financial constraints. Learn to write the report in non-technical as well as technical terms as it will be read by many non-aviation experts. Finally, share the final draft with all those who have helped you in the investigation before submitting the final report in your state, as some times it is difficult to release the final report depending on state rules.

### Investigation: art and science

The total lesson learned was that in the states where the aircraft accident investigation maturity level is 4, i.e., highly developed as per the maturity matrix given in the Global Aviation Safety Roadmap, aircraft accident investigation is carried out in a scientific manner. In states where national legislation is not in accordance with the ICAO SARPS, investigation procedures are not in place, the government and industry do not share incident data, the investigation bodies are not independent, acute shortage of technical personnel exist, and inconsistent implementation of international standards is at large, the investigation is an art. If the major stakeholders of aviation safety want to improve avia-

tion safety, they need to look for new approaches other than the traditional ones, which are normally through ICAO and states.

#### **Proposal to international aviation stakeholders**

I would take this opportunity to convey the experience I had while working in Pakistan for implementation of the Global Aviation Safety Roadmap, which is a strategic action plan for future aviation safety developed jointly by ACI, Airbus, Boeing, CANSO, the FSF, the IATA, and IFALPA for ICAO, states, and industry. It is sad that there has been no progress on this roadmap.

It is discouraging for those organizations that have worked for this Roadmap with a desire to improve aviation safety and have invested large sums as donors. Similarly, if we see the effectiveness of similar plans in the field of education, poverty reduction, drug addiction, health, infrastructure development, and judicial systems, it is evident that efforts of donor agencies have not been fruitful through state organs. The funds have either been misused or wasted due to inefficiencies. However, on the other hand,

significant progress is visible in the fields of education, health, infrastructure, etc. through non-governmental organizations.

Aviation safety is no exception to this reality; therefore, I propose to the global aviation stakeholders to consider the mobilization of human resource in this field through NGOs. Countries in south Asia have a large number of aviation experts who have spent their lives for the cause of aviation safety. There are pilots, engineers, and air traffic controllers who have vast experience in civil aviation but could not contribute much while serving under oppressive and authoritative cultures of government organizations. They are still trying to improve aviation safety through individual efforts. Their efforts need to be organized and that is possible through NGOs supported by international donors. At least these groups can take the lead in promoting awareness, education and motivation for safety in the industry as well as in government organizations. They can be an independent source of information for international bodies as well.

NGOs can be the best tool for improving global aviation safety. ♦



# What Can We Learn?

By Graham Braithwaite (MO3644), Cranfield Safety and Accident Investigation Centre,  
Cranfield University, Beds, MK43 0AL, UK



**Graham Braithwaite** is head of the Department of Air Transport at Cranfield University, UK. He was appointed as director of the Safety and Accident Investigation Centre in 2003 and awarded a chair in Safety and Accident Investigation in 2006. Prior to this, he worked as a lecturer at the University of New South Wales, Sydney. Graham holds a Ph.D. in aviation safety management from Loughborough University and his research has focused on issues of safety, culture, and investigator training.

*“For the things we have to learn before we can do them, we learn by doing them.”—Aristotle*

## Abstract

Each year, dozens of new investigators begin their training in aircraft accident investigation. Before them lay numerous traps and pitfalls to frustrate their transition from their first specialism as a pilot, engineer, air traffic controller, human factors specialist, etc., to that of “specialist generalist” investigator. The temptation to “revert to type,” especially when facing an unfamiliar situation and with the heavy weight of expectations, is a real challenge. Yet as major accidents become thankfully less frequent, the firsthand experience of long-serving investigators is becoming limited and as such, some of the same traps lie in wait, only arguably with more significant consequences. This paper highlights the role of higher fidelity simulation and continued self-assessment as two ways to assist even experienced aircraft accident investigators to continue to take a scientific approach to their art.

## Introduction

The experience of an accident investigator is hard earned, yet many new investigators find themselves placed on duty immediately after their basic training, sometimes only to receive their first call-out within days. For a majority of those, their prior experience as a pilot, engineer, air traffic controller, or other specialist will provide the reason for them to be appointed as investigator. However, the transition from operator to investigator is not always an easy one. This paper reflects on some of the challenges facing new investigators to ask the question, what can we learn from their experience?

## Old habits die hard

Each year, dozens of new investigators are recruited by government agencies, regulators, operators, insurers, and manufacturers. Whilst they are recruited primarily for their experience, there are also certain personality traits that allow them to adopt a fair investigative approach. One of the key challenges is making the transition from their original specialism to that of an investigator. However, there is some debate as to whether an investigator must remain a specialist or will in fact become a generalist (former AAIB Chief Ken Smart argues the correct description is a “specialist generalist”). What seems clear is that many of the habits or

biases of the original specialism can pervade the new role. A few examples include the following:

### Let me through, I’m an accident investigator!

Former AAIB Principal Inspector Eddie Trimble always reminded new investigators that the first thing to do at an accident site was place their hands firmly in their pockets and think before doing anything else. The temptation to avoid such sage advice is considerable, even for experienced safety professionals. This is partly understandable as emergency services are likely to be actively involved before investigators turn up on site. Influenced by the heavy weight of expectations, the perceived pressure for the investigator to be seen doing something straight away is significant. Numerous simulations have demonstrated this behavior, with examples including investigators walking on the wreckage trail, matching up fracture surfaces, and ignoring basic personal protective equipment needs. Experience is a partial fix for this, but the investigation community should be aware that the natural temptation for anyone on-site is to “get on with it,” which may have an effect on the preservation of evidence or the safety of the individual.

Even when it is appropriate to get on with the site phase, there remains the temptation to focus on certain aspects and miss perishable, or more important, evidence. Faced with a scene of chaos, it is a normal reaction to start to tunnel or focus in on a small number of cues as a coping mechanism. Believing that the investigation authority has unlimited powers to keep the site unaltered for as long as it wishes forgets the need for cooperation that lies at the heart of successful investigation. Generally, the art is of diplomacy regardless of what the documented procedures say *should* happen.

### The temptation to still be a regulator

It is easy to pick on the regulator when discussing no-blame investigation, but such criticism is sometimes warranted. However, many will have at least heard of the stereotypical regulator who cites regulations and tends to assume those who have failed to follow them are violators who should be punished. The temptation for investigators to become the identifiers of failure, the spotters of error, is great, especially when nervous and inexperienced. While identifying what went wrong is an important step, it can be all too tempting to stop at the first “eureka moment.” Indeed in one example (during simulation), it was a non-contributory paperwork error that became the focus of a regulator/investigator. Having found a problem, the individual then proceeded to aggressively interview an engineer who had actually acted appropriately. The discussion became increasingly heated and the engineer became uncooperative, leading the investigator to conclude he had definitely found the problem. Upon debrief, it was established that the error was minor—the sort of inconsequential error that any system is designed to tolerate—and in no way connected to the accident. The engineer explained that he had taken great exception to the accusatory style and had responded accordingly.

As Dekker (2002) reminds us, “The point of an investigation is not to find out where people went wrong, it is to understand why their assessments and actions made sense at the time.” Further, armed with an understanding of why systems fail, the role of the investigator is to comprehend how failures occur, taking into consideration the redundancies, margins, processes, and procedures that are designed to allow a system to function.

### The temptation to still be a pilot

For pilots in particular, the world is often ordered in terms of standard operating procedures and checklists. An early frustration for some investigators is to be told that accident investigation is not generally checklist based. Processes need to be adaptable to the specifics of a particular accident and, more importantly, the investigator needs to be able to think creatively. While *aide memoires* can be helpful, a checklist-based approach to the investigation task is rarely able to cope with the complexities of a particular accident. In such circumstances, the new investigator can quickly revert to type. Similar challenges present themselves for air traffic controllers, engineers, and so on—often because it has become part of their culture, and as such is carried over to the new environment while remaining invisible to those immersed in it.

Hindsight bias is often cited as a threat to impartial investigation, but it remains a particular challenge for new investigators. Comparing what was done with what the investigator believes they would have done in a similar situation is a trap. Investigators rarely face the same set of cues/inputs at the same time or while feeling the same way that those involved in accidents did. Simply put, if it seems that someone has done something stupid, the challenge is to question whether the interpretation is correct—sometimes it will be, but far less often than some may think. Where a pilot makes an error that the investigator does not believe they personally would make, this does not necessarily equate with bad airmanship. The investigator must establish the context of any human act before being tempted to pass judgment.

### Nobody told me it would be like this....

The experience of being on site for the first time is a vivid memory for most investigators, and some are better prepared for it than others. Faith (1996) observes “No rehearsal, no amount of experience or careful preparation...can ever prepare an investigator for what he finds on site.” Faith goes on to cite former NTSB investigator Greg Feith who describes his experience: “The actual arrival at an accident site is probably the most traumatic thing anyone could ever experience.” How do we best prepare new investigators for this experience, and what can we learn from their reactions? For example, simulations at Cranfield have more recently used theatrical blood as a prop during simulation, with strong effect. Several investigators were noticeably shocked even though they were fully aware they were involved in a simulation. Similarly the use of emotional witnesses or those with challenging attitudes and experience has highlighted the difficulty in moving from classroom theory to application.

When an investigator is deployed into their new role, they do not always experience what they were expecting when they signed up. For example, one (marine) investigator had not expected to deal directly with dead bodies, assuming that as crashworthiness was not a major issue in his industry, the deceased would have been removed prior to his arrival on scene. His first investigation

proved this not to be the case. As the accident vessel was winched onto the dock, all other services looked to him to be first on board, something he found very traumatic.

Other challenges have come about because society’s expectations of what the investigation should deliver have grown. For example, liaising with those affected by an accident such as survivors, friends, and relatives has added an increased load to the already multitasking investigator. Not everyone expects to play this role, and some new investigators have found this to be an unexpected problem. For example, a rail accident investigator found the concept of not using names in an accident report to be a logical approach during training. However, on participating in an investigation where two young girls had been hit by a train while rushing across a crossing, the investigator felt it was going to be very difficult to explain to the parents that their daughters would not be named in the final report.

This event also highlights the fact that the type of experience gained in the field is primarily dictated by accidents that occur. Although common skills pervade many different types of accident, the general improvement in aviation safety provides a particular challenge. Simply put, many investigators have minimal opportunity to practice their skills before needing to tackle a major investigation. In China, for example, where the aviation industry is growing rapidly, there is minimal general aviation, so investigators find they are more likely to be involved with events involving high-capacity regular public transport aircraft than, say, their British equivalents.

The improvement in safety is, of course, a good thing, but perhaps it is time that we considered more carefully the use of simulation in *ab initio* and recurrent training to help investigators to build their experience. Even relatively small-scale simulations can illustrate the sorts of things that will happen on-site, such as the challenge of everything happening at once. However, simulations are presently limited by the size of event that can be staged and the duration for which it can run. How substantial a simulation would it take to be able to deliver the sort of experience that the AAIB, the NTSB, Boeing, and Rolls-Royce investigators are currently undergoing following the B-777 accident at Heathrow?

Avoiding these traps and pitfalls is a worthwhile goal, but what else stands in the way of the new investigator? It is experience, not in their original specialism, but in their new one, the much-harder-to-define role of accident investigator. This experience is hard won and, it is argued, becoming harder for some to gain.

### The trusted investigator

Accident investigation, as defined by ICAO Annex 13, is dependent on trust. Such trust takes many forms: whether it be trust that evidence collected by the investigation will not be used to allocate blame; trust that confidentiality or dignity will be respected; or more fundamentally, that the investigation will be accurate and correct. In terms of the expectation of the industry and society at large, Bibel (2008) remarks, “We trust that an investigation will pinpoint the cause(s) of the accident and deliver lessons that will protect us in the future.” Indeed, part of society’s valuation of safety, according to Cobb and Primo (2003) is the “absence of unsolved crashes.” In other words, it is the trust that the air transport industry is able to understand and learn from its failures.

Where does the trust in accident investigation actually come from? While within the industry, it is partly based on the way in which investigations are conducted, for the general population it seems

more to do with the way in which investigators are apparently able to make sense from chaos. Weir (1999) describes investigators as follows; “Of all the insiders in the aviation business, the air-crash investigators are the airline passenger’s best allies. Their job is to attempt to prevent the things we fear the most.” Reason observes, “Like the rest of the modern world, I owe an enormous debt to the skills of professional accident investigators. As a traveler and a consumer, I am extremely grateful for what they have done to make complex technologies significantly safer.” (Strauch, 2002)

During training, it is the building of trust and credibility that many new investigators identify as their priority. So how is this best achieved? This is one aspect where the science is arguably rather easier than the art. Understanding the legislation, the theory of interviewing, different modes of failure, and so on seems more achievable than understanding how to combine these multiple inputs and deliver an answer that is accurate and will actually help to make the industry safer. The art lies in exhibiting the difficult to quantify concept that is “investigative judgment.”

### Scientist or artist?

A scientist may be described as “a person who is studying or has expert knowledge of one or more of the natural or physical sciences.” (*Concise Oxford English Dictionary*, 2006) Scientists maintain their skill levels through practice and through maintaining their knowledge of the research literature. By doing the job, the scientist can maintain their currency, but such a vast topic cannot be covered by one scientist and is therefore dependent on being able to cite and link to the work of others.

An artist may be described as “a person skilled at a particular task or occupation, for example, a surgeon who is an artist with the scalpel.” More commonly, the term artist is used to describe “a performer, such as a singer, actor, or dancer.” (Apple, 2008) It is arguable that for many artists, their talent lies way beyond their training. This notwithstanding, even great artists need practice to become, and remain, successful. Expectations of their ability can place considerable pressure upon them and few artists remain at the top of their game throughout their career.

So which best describes the accident investigator?

Investigation, like scientific research, requires disinterest, impartiality, and a desire to reach the truth, whether it fits your previous model, first guess, last 6 months work, or not. However, like art, accident investigation also requires creativity, understanding, passion, commitment, and emotion. New recruits cite traits from both categories (see Braithwaite, 2004) as being important qualities of an investigator, yet it is rare for all of the best traits to exist in just one category. It is clear that neither the pure scientist nor the pure artist will succeed and for many, this means the need to blend together two quite different approaches.

### Scientist and artist?

Perhaps, just as the “specialist generalist” describes the investigator, so does the description of “artistic scientist” (or “scientific artist” for that matter)? The investigation of events within a complex socio-technical system such as aviation depends on a mixture of deductive and inductive logic. The former, where particular instances are explained in terms of a general law, depends upon absolute confidence in the data. Is it more likely then that an investigator would be dependent on inductive logic, where a particular instance is used to infer the presence of a general law.

In other words, inductive logic depends on the investigator making inductive “leaps” on the basis of the weight of available evidence. Such evidence may be of variable form and quality e.g. physical evidence, witness statements, digital data, and so on. As the Australian Transport Safety Bureau (ATSB) analysis review reported “safety investigations require analysis of complex sets of data and situations where the available data can be vague, incomplete, and misleading.” (Bills and Walker, 2008)

Similar to the work of social scientists, the investigator is looking for convergence of evidence while also maintaining vigilance for their own biases. This is often a difficult transition for investigators to make, especially if they are used to precision and order in their prior aviation career. Witness evidence is a particular case in point where “expert” witnesses may seem more compelling than those who perhaps look or sound less credible. Similarly, it is known that unlikely explanations are much harder to accept than likely ones even when the strength of evidence may actually be the same. Learning this skill is perhaps the hardest of all, especially when even experienced investigators struggle to articulate their own approach.

For example, myriad analysis tools abound, but the majority are suitable only for certain elements of the overall analysis. For example, fault trees may be a logical way of dealing with component or physical system failures, but will struggle to handle less tangible factors such as the influence of, say, culture or training. Even where investigation approaches have been defined, such as the Integrated Investigation Process or indeed some of the applications of Reason’s organizational accident model, they tend to provide a framework, rather than the rigid methodology that some expect. There is certainly scope for improvement, even among the leaders in this area. The Queensland state coroner complimented the ATSB’s work to refine the way in which it approaches accident investigation. “The Bureau is to be commended for attempting to adopt a scientific approach to what has been, in many instances treated as an art form.” (Bills and Walker, 2008) However, this did not stop the coroner from then voicing concerns over the standard of proof that was considered to be acceptable. Mike Walker will speak of this important work during this conference and it is to be applauded as a major step forward. Putting it into practice, however, shows some of the depth of the challenge, especially when many new investigators start with great optimism about the clarity of evidence that will be presented to them.

### Maintaining competency

While gaining enough experience to start investigating is one task, how to nurture and preserve some of the skills is another problem. In other words, how do investigators maintain their competency in what they do? There is a distinction between being competent (being able to demonstrate abilities upon recruitment) and maintaining competency throughout an investigator’s career (maintaining currency in their skills). As mentioned above, the nature of investigation is such that it is often the accidents themselves or the position of the investigator on the call-out list that will determine what skills are exercised at any one time.

Writing more than 20 years ago about the impossibility of guaranteeing personal experience of a particular aircraft type for each investigator, former UK AIB Chief Bill Tench (1985) observed, “What you can and must do, however, is ensure that all the investigators are expert in every sense in the techniques of investiga-



tion and *au fait* with all aspects of operating modern aircraft..., but they must also have access to reliable and impartial specialists in the type of aircraft concerned.” Unfortunately, some of the specialists are heading toward retirement, or have recently retired. For example, those investigators who were involved in the two major aircraft accidents at Lockerbie (1988) and Kegworth (1989) are dwindling in number within the AAIB.

### What can experienced investigators learn?

Firstly, we should acknowledge that with the reduction in large-scale aircraft accidents, so a greater number of inexperienced investigators will find themselves having to deal with large accidents. This is against the backdrop of society’s expectations that they will find the answer, the news media’s expectation that it will be found now, and the legal industry’s expectation that whatever it comes up with can still be challenged! Many of the traps remain a hazard for even the experienced investigator, except that their consequences may be greater. Even if the lead investigation agency is able to send suitably experienced staff, many of those other agencies that may also have an interest will be starting with minimal experience. For example, how many modern airlines have staff with direct experience of dealing with an aircraft accident?

Even for the experienced air safety investigators, how often do they challenge themselves as to whether they are doing the right thing? Although the very nature of accident investigation requires constant challenge of the meaning of evidence, perhaps the overall approach taken to evidence collection, analysis, or recommendation-making is something that needs periodic review? There are a plethora of analysis methods, with their relative strengths and weaknesses, that are applied to varying standards by different investigators.

The new investigator also has a contribution to make to this process as often the inexperienced ask some of the most searching questions, in part because they haven’t yet learned not to. At times, underlying a question of “why is it done that way?” might be the question “because wouldn’t this way be better?” These questions can be an opportunity to constantly reassess and revalidate existing techniques that are always open to improvement.

While recognizing that there are some exceptions, such as the Transportation Safety Board of Canada (TSB) and the ATSB, even they would admit that we still have a long way to go in terms of developing reliable analysis processes. Whilst theories such as Reason’s organizational accident model are generally widely accepted and even cited by ICAO (1993), really good investigations into these areas are still comparatively rare. Similarly, recommendations remain an area where experienced investigators can do well to listen to the perspectives of new investigators, fresh in from the industry. As Wood and Sweginnis noted (1995), good investigators “listen to other investigators. They don’t necessarily believe them, but they do listen to them.”

### How can we better educate investigators?

While a lack of experience with large accidents will lead to new challenges being faced by all involved when such an event happens, many of these challenges can be anticipated. However, how many of us have detailed, tested plans in place to respond to, say, an A380 or B-787 catastrophe?

There is an argument to be made that the “void” created by the lack of large accidents (be it real or virtual) should not be entirely filled by smaller investigations. Time and space in an

investigator’s workload should also be made for training, simulation, skill review, etc. This could range from full-blown response, investigation, and analysis simulations to much shorter “what if?” tabletop sessions.

In addition, since the majority of training for most investigators will be “on the job,” it befalls the more experienced investigator to take some responsibility for educating others. It is here that continual monitoring of one’s own practices can lead to gains for both parties. Reassessing procedures (what and why?) not only leads to improvement of those procedures but also helps to remind the more experienced of when they were new. The worst teachers are those who cannot remember what it is like not to know or understand, and often those same people are the worst at learning new things or updating existing thinking.

There is also a large role to be played by training organizations, whether it be in *ab initio* training or in more advanced continuing development. Carefully developed simulations can provide a high level of fidelity, thereby allowing investigators a “safe” environment in which to practice and develop skills that they may otherwise not have had a chance to acquire. Increasingly, these simulations incorporate not only the technical aspects of the field investigations (the science), but also the less tangible aspects such as analysis, critical thinking, group dynamics, etc., (the art). The parallel with flightdeck simulation is clear with original simulations focusing on technical skills, and later refinements adding non-technical skills such as crew resource management (CRM) and threat and error management (TEM).

The difficulty, and also part of the attraction, of investigation is the variety of disciplines, approaches, knowledge, and personalities required to carry out a successful investigation. Myriad qualities are required with those of both artist and scientist featuring strongly and hence the types of people involved are also myriad. However, regardless of background and experience it is important to remember that investigation, is as much a way of thinking, an approach, as it is specific knowledge or experience and for that reason all involved can contribute to the process and its outcomes; or as Ron Schleede put it, “It takes all kinds of people to make it click.” (cited in Faith, 1996) ♦

### References

- Bills K.M. and Walker, M.B. (2007) Analysis, Causality, and Proof in Safety Investigations Report No. AR-2007-053. Australian Transport Safety Bureau, Canberra.
- Bibel, G. (2008) Beyond the Black Box: The Forensics of Airplane Crashes. The John Hopkins University Press, Baltimore.
- Braithwaite, G.R. (2004) Re-Inventing (With Wheels, Wings, and Sails)—A New Look at Transport Accident Investigator Training. Paper Presented at ISASI 2004, International Society of Air Safety Investigators Annual Conference, 2004. Gold Coast, Australia.
- Dekker, S.W.A. (2002) The Field Guide to Human Error Investigations. Ashgate, Aldershot.
- Faith, N. (1996) Black Box: Why Air Safety is No Accident. Boxtree, London.
- ICAO (1993) Human Factors Digest No. 10: Human Factors, Management, and Organization. Circular 247. International Civil Aviation Organization, Montreal.
- Strauch, B. (2002) Investigating Human Error: Incidents, Accidents, and Complex Systems. Ashgate, Aldershot.
- Tench, W.H. (1985) Safety is No Accident. Collins Professional and Technical Books, London.
- The Concise Oxford English Dictionary (2006) Eleventh edition revised. Ed. Catherine Soanes and Angus Stevenson. Oxford University Press, 2006.
- Weir, A. (1999) The Tombstone Imperative: The Truth About Air Safety. Simon and Schuster, London.
- Wood, R.H. and Sweginnis, R.W. (1995) Aircraft Accident Investigation. Endeavor Books, Casper.

# Accident Investigation— A Complete Service?

By Phil Taylor, Senior Inspector of Air Accidents (Operations), UK AAIB



**Phil Taylor** trained as an aeronautical engineer and helicopter pilot with the Royal Navy. He served on frontline squadrons and as a helicopter maintenance test pilot and also achieved chartered engineer status. After 17 years' service, he retired from the Royal Navy and joined a regional airline, where he flew turbo-prop and regional jet aircraft and became the company's chief pilot. Phil joined the AAIB as an operations investigator in 2002 and has investigated accidents and incidents to most classes of aircraft, both fixed and rotary wing, in the UK and overseas. He holds ATLP licenses for aeroplanes and helicopters and maintains his fixed-wing currency by flying online operations with a commercial operator. He has recently converted to the Boeing 757 and Boeing 767 and continues to fly helicopters.

One of my brothers who is a dental surgeon once told me that one of the things that attracted him to the profession was the fact that when a patient comes to him with a dental problem, he can follow their treatment all the way through to the end (Figure 1). Does this also apply to air accident investigation? Who are our patients or, more appropriately, stakeholders? At face value, it might seem obvious; they are the operators, the manufacturers, and regulators, the bodies to whom we make our recommendations. However, those affected by our work also include passengers, bereaved relatives and friends, and, in some instances, the public at large. Do we provide all of them with a complete service?

In searching for a suitable definition of complete service, I came across many companies that claim to provide what they term a complete service.

## Introduction

While attending ISASI 2007 in Singapore last year I scribbled a note to myself. It simply said "Air Accident Investigation—A Complete Service." What prompted me to write it, I am not sure. However, when the title of this year's ISASI international seminar was announced, it triggered the same thought but with a question mark at the end.

I would like to consider what the expression "complete service" might mean. Then, taking the theme "Accident Investigation—The Art and the Science," the paper will briefly review the ingredients involved in the process, from notification to safety recommendation action, and consider those who benefit, in whatever sphere of interest, from the final report.

Examples from investigations will be used to illustrate the content of the paper, and some that confirm or challenge the notion of completeness will be referred to. The paper will discuss improvements that could be made to enhance the process, including advances in technology.

Finally, the paper will consider an aspect of accident investigation that seems fundamental to its success and the integrity of the process. It will sum up by proposing that the completeness of investigations could be improved with the introduction of light-weight flight data and voice recorders on smaller aircraft.

## A complete service

Figure 1

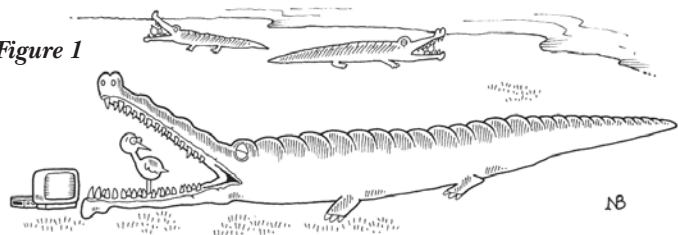

"Just pick my teeth - skip the video on oral hygiene."

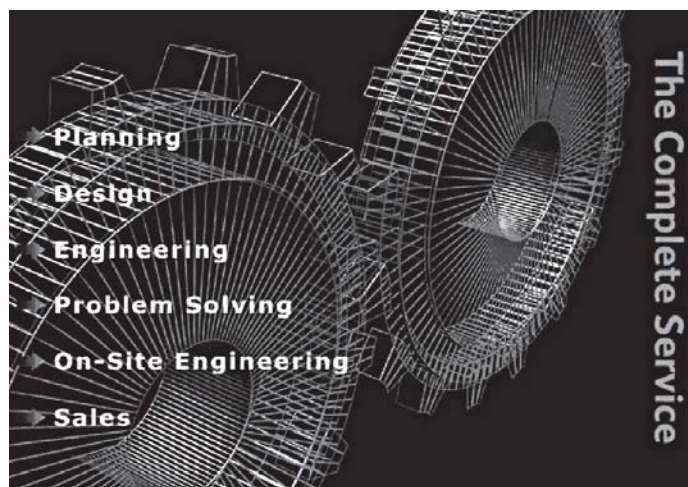

Figure 2: A more complete service.







Figure 3



Figure 4



Figure 5

One dictionary definition of “complete” is “perfect in quality or kind.” For “service” it gives “performance or work for another.” Combined this gives “work, perfect in quality, for another.”

There were other definitions for “complete,” including “finished,” and for “service,” “a periodic overhaul made on an automobile or machine”—making a “complete service” a “finished periodic overhaul on an automobile or machine.” But that doesn’t apply here!

Insofar as the sole objective of accident investigation is the prevention of accidents and incidents, our work is clearly not finished, but is it perfect in quality. One Irish poet once wrote, “Finality is death, perfection is finality; nothing is perfect, there are lumps in it.” However, an English cleric said, more optimistically, “Perfection is the child of time.”

The procedure for the notification of accidents and serious incidents is clearly laid out in the appropriate manuals and, with rapid means of communication, the transmission and receipt of this notification is often very speedy. This enables investigation teams to be formed quickly and, with modern-day transport, reach very remote accident sites, assisted in the location process by Emergency locator transmitters. Thereafter, the analysis of evidence, witness statements and data often produces reports that are able to provide comprehensive findings and causes from which



Figure 6

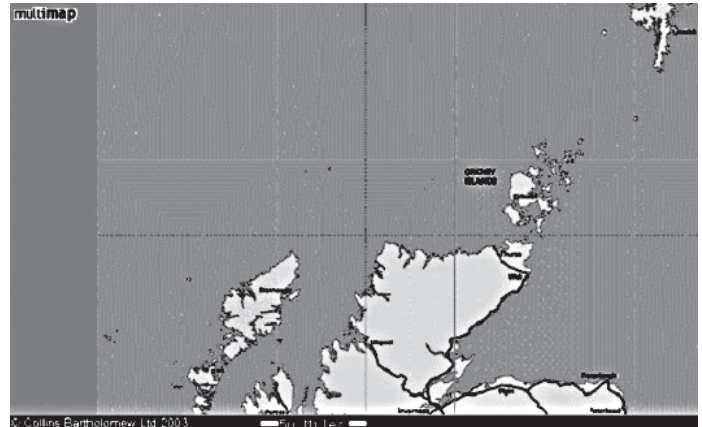

Figure 7

appropriate safety recommendations can be made.

In August 1985, a Boeing 737, registration G-BGJL, suffered an uncontained failure of the left engine during its takeoff from Runway 24 at Manchester in the UK (Figure 3). A wing fuel tank access panel was punctured and leaking fuel ignited as the take-off was rejected.

Tragically, during the subsequent fire and evacuation 55 of the 137 passengers and crew on board lost their lives, and the aircraft was destroyed (Figures 4 and 5).

The investigation team had access to the damaged aircraft, recorded data, medical and pathological information, and witness statements. The investigation included much testing and research and the comprehensive final report on the accident made 31 recommendations to the regulator, operators, and manufacturers.

In that investigation, as in many others, a lot of data and witness evidence were available to the investigation team. However, that is not always the case—particularly where there is no requirement for the aircraft to be equipped with an FDR or CVR and there are few witnesses.

In October 2004, a Reims Cessna F406, G-TWIG, took off from Stornoway, in the Outer Hebrides, to the west of Scotland, to return to Inverness on the mainland (Figure 6).

The aircraft had earlier delivered newspapers and magazines to the Orkneys and Shetland Islands and was returning empty with only the pilot on board.

The aircraft climbed to its cruise level of Flight Level 95 where it flew in or between cloud layers in much the same conditions as it had encountered flying in the opposite direction earlier that morning (Figure 7). The pilot of another aircraft that followed





Figure 8



Figure 9

the same route about 20 minutes later stated that there was no icing or turbulence at his level, FL75. Shortly after G-TWIG began its descent for the approach to Inverness Airport, it disappeared from radar at FL78 and contact with the pilot was lost.

A day later, the remains of the aircraft and the pilot were found in a remote location on the Scottish highlands within a few hundred meters of the position of the final radar return (Figure 8).

The aircraft was very badly fragmented, so much so that from the air it was difficult to distinguish from the surrounding rocks and vegetation and was ultimately discovered by a mountain rescue team that had joined the search (Figure 9).

It was established that the aircraft was structurally intact when it struck the ground in an estimated 70° nose-down attitude with its longitudinal axis at an angle of 68° to the ground at impact, i.e., left wing low (Figures 10 and 11). The extreme fragmentation of the wreckage suggested a high impact speed, probably in the region of 350 kts. Evidence suggested that the engines were producing a significant amount of power and that the elevator trim actuators were near to their full nose-down position.

What caused the aircraft to carry out an apparently dramatic maneuver could not be established, and there was nothing to indicate that the pilot contributed to the aircraft's departure from its flight path.

This was an unusual accident. Those with a close interest in the final report were the airline, other F406 operators, the manufacturer and, also the pilot's family, friends, and his fiancée. Ultimately we were unable to determine what had happened or why. We considered it possible that the pilot may have become incapacitated. Internationally agreed standards did not require G-TWIG to carry either a flight data recorder or a cockpit voice



Figure 10 (above) and Figure 11 (left)

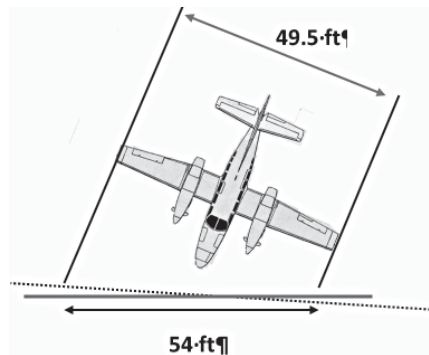

recorder. Had it been, we would have stood a better chance of determining what had occurred, although the why may still have eluded us.

In July 2002, a Robinson R22 helicopter, registration G-VFSI, took off from an airfield in the middle of England for a sightseeing flight around the town of Warwick. On board were the pilot and his girlfriend's father. The pilot had already completed three flights earlier that day with a friend and, separately, his girlfriend's mother. The weather was good and the aircraft followed the same route as it had on the previous flight. We established this from data that were later retrieved from GPS equipment recovered from the wrecked aircraft.

Abeam the western edge of Warwick, with the aircraft flying level at a height of about 1,500 feet and cruising at about 70 kts, it was seen to break up in flight and descend into a field. Evidence also included various eyewitness accounts and photographs that had been taken by a camera that was recovered from the helicopter (Figure 12). The data from the GPS equipment and the photographs gave us information on the aircraft's altitude and ground-speed shortly before the accident and an indication of what the



Figure 12



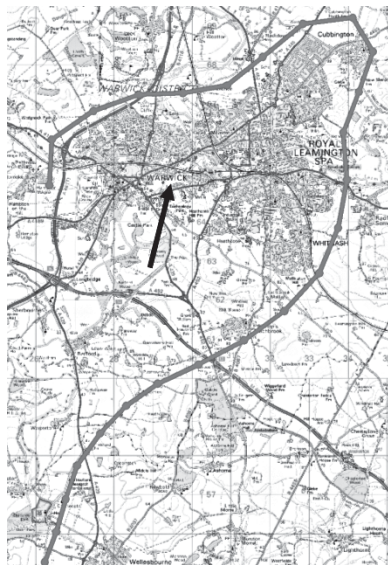

Figure 13

in this case it was considered possible that this occurred as the result of an unintentional input on either the cyclic control or yaw pedals, or both.

Again, we were unable to establish with certainty what had caused the accident and answer the questions that were of particular interest to owners and operators of R22 helicopters, the manufacturer, and the two families and friends of the deceased pilot and his passenger. Notably, this was one of a number of investigations in which we have been able to use GPS data to establish some elements of the history of the flight.

In July 2003, a Hughes 500C helicopter, registration G-CSPJ, took off from Biggin Hill airfield, an aerodrome near London for a flight in the local area. The weather was good and the pilot was accompanied by his wife, who was 3 months' pregnant, and their 4-year-old son. Within 2 minutes of its departure, the aircraft had descended from a height of about 400 ft, turned left through approximately 130°, and crashed into a field in an estimated 30° nose-down attitude and at a forward speed of approximately 80 kts (Figures 14 and 15).

Witness statements were compared with radar data that recorded some of the flight. Also, radio calls between the pilot and ATC were analyzed. Shortly before the accident the pilot was instructed to change radio frequency, an instruction that had to be repeated by ATC. The pilot acknowledged the second call by ATC and gave no indication what had distracted him from hearing the first call or that there was any problem. A brief transmission on the new frequency, which was timed just before the moment the aircraft crashed, was considered to have been made by the pilot. It was a brief distressed utterance rather than recognized RTF. This established that the pilot had successfully changed frequency on the combined communications and navigation equipment, on which it was possible to toggle between communications and navigation frequencies while making such a change. While it was possible that the time it took the pilot to change frequency may have been an ingredient, it was unclear why the aircraft, piloted by someone who was, by all accounts, very safety conscious, should crash in this fashion in such benign conditions.

The investigation revealed no evidence of any pre-impact faults in the aircraft. A number of possible explanations were explored

passenger had been doing seconds before the aircraft broke up. We also recovered radar data that corroborated the aircraft's track and showed the flight paths of other aircraft in the area, which was of assistance in determining whether wake turbulence had been a factor. It was considered not to have been (Figure 13).

Evidence suggested that, as a result of mast bumping, the tail cone of the aircraft was struck by the main rotor blades. This can be caused by abrupt control inputs and,



Figures 14 (above) and 15 (left)

but each was flawed. As a result of insufficient information, the cause or causes of this accident,

which happened in good weather and shortly after departure from Biggin Hill Airport, remain unresolved. This was unsatisfactory from two perspectives. It was not possible to state what measure or measures would prevent such an unusual accident from happening again and, secondly, those with a personal interest may never know why the accident occurred. This might not have been the case if the aircraft had been fitted with a flight data recorder or cockpit voice recorder or both. No such equipment was required or fitted on this aircraft.

Once more, as well as other operators and the manufacturer, two families and the friends of the deceased were particularly interested in the outcome of the investigation. Also, the local population in the area, where there have been other accidents, had a vested interest in the findings.

Two recommendations were made urging the promotion of the safety benefits of fitting, as a minimum, cockpit voice recording equipment to all aircraft operating with a certificate of airworthiness in the commercial air transport category, regardless of weight or age and, secondly, urging the promotion of research into the design and development of inexpensive, lightweight, airborne flight data and voice recording equipment. These and another similar recommendation relating to appropriate recording equipment that can be practically implemented on small aircraft were reiterated in the report on the accident involving the F406, G-TWIG.

The helicopter accidents I have referred to will be amongst the accidents that attract the attention of the International Helicopter Safety Team and its European partner, the European Helicopter Safety Team, as they endeavor to reduce helicopter accidents by 80% in the 10-year period up to 2016. In these and many other accidents involving light aircraft, data from suitable lightweight recorders for flight data and voice would greatly assist investigation teams. GPS equipment and cameras, which sur-

Figure 16



affairs and the independence of an accident investigation authority is important in being able to provide a complete service in which all stakeholders can have confidence.

I would briefly like to mention a third aspect of our global efforts to improve aviation safety, and it is a subject that could be a point of discussion on its own. It is the matter of mutual assistance. States have different strengths, and sharing them seems the best way to tackle aviation safety on a global scale. As technology and skills develop, strengths vary and fluctuate. That seems logical. There is the provision for assistance between states, and outreach programs provide helpful training. However, when assistance is requested, perhaps there is more that could be done. The speed with which a suitable response can be delivered raises the question as to whether more cannot be done before the perceived need is challenged.

vive an accident sufficiently to provide an incomplete record of the flight, give a glimpse of how useful such recorders could be. This would not only assist the investigation teams but would also provide greater closure for those with a personal interest in an accident and present independent evidence for a concerned general public, whose fears can be fuelled if there is an absence of proven facts.

In March 2006, a Hawker Siddeley HS748, G-BVOV, overran the runway at Guernsey Airport, in the Channel Islands, while landing in poor weather (Figure 16).

The aircraft suffered damage to two tires but was otherwise unscathed. The operator had been involved in previous serious incidents that had been investigated by the AAIB and had a history of non-conformities being raised during audits by the regulator and had been closely monitored for at least 2 years. Concerns included the operator's management structure and competencies, and its ability to maintain standards of safety. Shortly after this incident, the operator's AOC was suspended by the regulator and the company subsequently ceased trading.

The investigation revealed a trend of shortcomings that were not addressed by the operator despite assurances to the regulator. The regulator had expended much effort in encouraging the operator to meet the required standard but this had not been achieved. In the final report, it was considered that a contributory factor to the incident was that close monitoring by the regulator had not revealed the depth of the lack of knowledge of standard operating procedures within the operator's Flight Operations Department until after the overrun incident. As a result, a recommendation was made to the regulator regarding its oversight of AOC holders in order to ensure that AOC holders meet and maintain the required standard. This recommendation was made only after very constructive and positive discussions between the AAIB and the regulator. While underlining the importance of good working relations between all those involved in ensuring aviation safety, it also exemplified the value of an independent investigation.

Examination of the recommendations that are made in accident and incident reports reveals that many are made to regulators. I would suggest that this is a thoroughly healthy state of

So, who benefits from our work? Operators, manufacturers, regulators, passengers, families and friends of the deceased and injured, and the public at large. Do we provide a complete service? There are many examples of excellent investigations that have brought about significant improvements in aviation safety. Instances in recent years where aircraft have crashed and caught fire or crashed and not caught fire and all the passengers and crew have successfully evacuated are indications of an improvement in survivability, although the avoidance of the accident in the first place is clearly the objective. However, the introduction of lightweight recorders would be of great assistance in those investigations involving aircraft that are not currently required to carry them so that the cause, or causes, can be established and suitable recommendations for prevention can be made. If we want to reduce the rate of accidents among helicopters, I would suggest that this could be significant step in that endeavor. I would also suggest that our global effort can be enhanced by increasing the speed of response to requests for assistance so that we are better prepared globally.

The independence of an investigation authority seems fundamental to the completeness of the service we provide, while also acknowledging that working closely with our various stakeholders, be they operators, manufacturers, regulators or members of the public, all of whom can provide us with information that enable us to carry out our investigations, is also important. The fact that we do not apportion blame or liability can only assist us in that aspect. The independence of an investigation surely enhances the integrity of the process and provides the beneficiaries of the results with confidence in the outcome.

In conclusion, do we perform "work, perfect in quality, for another"? It would be arrogant to suggest that we do, and I have indicated where there are some "lumps" in our endeavors to supply a complete service, although there are also many investigations that I suspect come very close to that ideal. Many investigations could be enhanced with the introduction of lightweight flight data and voice recorders on aircraft which are currently not required to be fitted with them. Also greater mutual assistance and support between states could help to achieve a more complete service globally. Not the least, maintaining the independence of the investigating authority is surely the basis of ensuring that the perception and reality of a complete investigation is realized. ♦



# Managing the Complexities of a Major Aviation Accident Investigation

By Joseph M. Kolly, Bruce G. Coury, Vernon S. Ellingstad, and Aaron S. Dietz  
National Transportation Safety Board, Washington, D.C., USA



**Joseph M. Kolly** is deputy director of the NTSB's Office of Research and Engineering where he is responsible for oversight of the Board's three laboratory divisions—the Materials Laboratory, the Vehicle Recorders Laboratory, and the Vehicle Performance Laboratory. He received his doctoral degree in mechanical engineering from the University of

Buffalo, New York, USA, in 1996, and was a senior research scientist at Calspan/University at Buffalo Research Center (CUBRC) before joining the Board in 1998.



**Bruce G. Coury** is a transportation research analyst in the NTSB's Office of Research and Engineering, Safety Studies and Statistical Analysis Division. His work at the Board has focused on transportation safety policy and practice. He earned his doctorate in industrial engineering and operations research at the University of Buffalo, New York, USA, and was a senior scientist at Johns Hopkins University Applied Physics Laboratory and associate professor in the Department of Industrial Engineering at the University of Massachusetts at Amherst before joining the NTSB in 2002.



**Vernon S. Ellingstad** is director of the NTSB's Office of Research and Engineering where he supervises all of the Board's laboratories that provide scientific and engineering support for investigations in all modes. He is also responsible for primary scientific and technical review of the Board's accident reports, studies, and other major products, and represents the Board's

positions on technical issues to government and industry. Prior to joining the NTSB in 1990, he was chairman of the Psychology Department, and director of the Human Factors Laboratory at the University of South Dakota, where he received his doctorate in 1969.



**Aaron S. Dietz** is an program analyst in the NTSB's Office of Research and Engineering, Safety Studies and Statistical Analysis Division. He has been working on the development of representation of critical accident events to support accident investigations. He earned his bachelor's degree in psychology and in economics from the University of Washington, Seattle, before joining the Board in 2007.

## Introduction

The United States National Transportation Safety Board (NTSB) is engaged in a strategic project to examine its accident investigation process. As a leader in transportation safety investigation, the NTSB is using its broad range of experience and technical

expertise to analyze and thereby improve its own investigative processes. The project is motivated both by lessons learned from current and past investigations, and by an expectation that future investigations will face increasing technical complexity and political and social pressures.

The project is taking a comprehensive look at all transportation modes under the Safety Board's purview—aviation, rail, marine, highway, and pipeline. The initial examination has revealed commonalities related to two very distinct phases of the investigation—on scene and post-on scene—that are guiding development of investigative methods and approaches. The on-scene phase—which includes both the initial launch and on-scene activities—is regarded as a highly successful phase of the investigation. This phase is characterized by the urgency, intensity, and reactivity of the work. Investigators rely on their wealth of experience and expertise in relatively focused operational and technical areas to quickly analyze the situation and collect perishable information. Two of the major advantages of the on-scene phase are direct communication among all participants and information sharing in daily progress meetings. Most participants are quickly and equally informed and able to easily contribute information to all other investigative efforts. Issues of importance are quickly identified, and the actions required to resolve them are rapidly formulated.

Once the on-scene phase is completed and the investigators have returned to headquarters, the investigation takes on a different character. The frequent interaction and information exchange while on scene gives way to individual investigators focusing on their own areas of concern in a specific area. The beneficial characteristics of on-scene communication and interaction diminish.

Our understanding of this change in character from on scene to post-on scene is helping us restructure how issues and information are managed in the investigation. The goal of the project is to develop and implement in post-on scene investigative activities the kinds of investigator interaction, communication, and treatment of issues and information found in the on-scene phase. Accordingly, the emphasis is on identifying, refining, and resolving issues, not the pursuit of investigative procedures and practices related to specific operational or technical areas. To this end, the project has established the following objectives:

- Increase efficiency in investigations by focusing on principal issues,
- Enhance communications and information access,
- Increase participation by entire core investigative team, and
- Provide a blueprint for report development.

In this paper, we describe the initial stages of the project where the accident investigation process was modeled and a method-

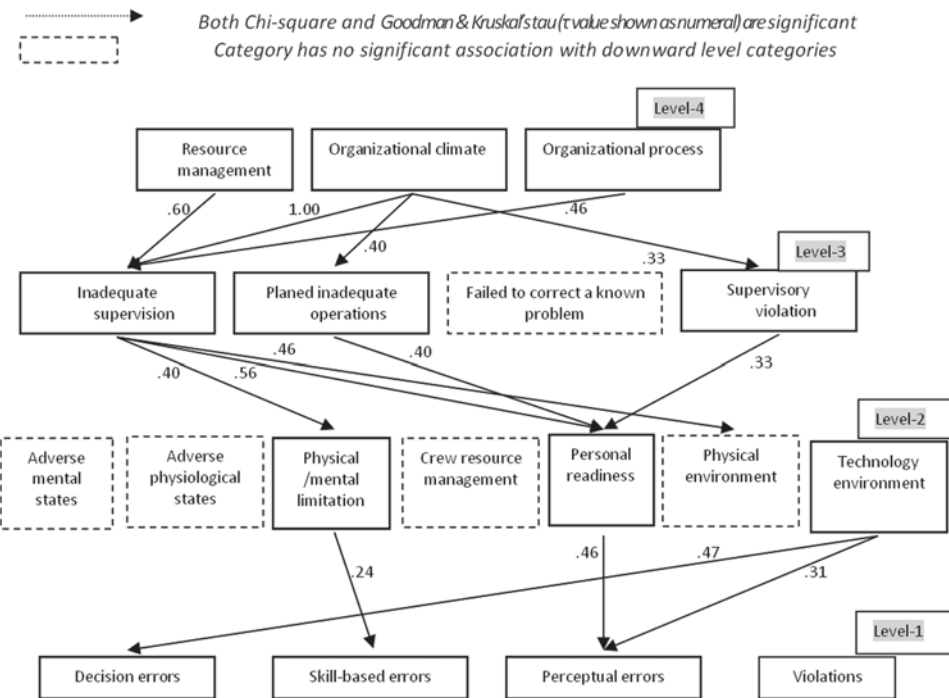

Figure 1. Major aviation accident investigation management structure.

HFACS Category		United Kingdom N=16		Taiwan N=16		Chi Square df = 1	
		Frequenc y	Percenta ge	Frequen cy	Percenta ge	Value	p
Level-4 Organizational Influences	Organizational process	15	93.8	11	68.8	3.29	<0.10
	Organizational climate	12	75.0	8	50.0	2.13	N/S
	Resource management	13	81.3	10	62.5	1.39	N/S
Level-3 Unsafe Supervision	Supervisory violation	12	75.0	12	75.0	0.00	N/S
	Failed to correct a known problem	10	62.5	13	81.3	1.39	N/S
	Planned inadequate operations	12	75.0	9	56.3	1.24	N/S
	Inadequate supervision	12	75.0	8	50.0	2.13	N/S
Level-2 Preconditions for Unsafe Acts	Technology environment	11	68.8	14	87.5	1.64	N/S
	Physical environment	5	31.3	5	31.3	0.00	N/S
	Personal readiness	5	31.3	8	50.0	1.16	N/S
	Crew resource management	15	93.8	15	93.8	0.00	N/S
	Physical/mental limitation	10	62.5	9	56.3	0.13	N/S
	Adverse physiological states	2	12.5	1	6.3	0.36	N/S
	Adverse mental states	15	93.8	6	37.5	11.22	<0.001
Level-1 Unsafe Acts of Operators	Violations	13	81.3	11	68.8	0.67	N/S
	Perceptual errors	5	31.3	11	68.8	4.50	<0.05
	Skilled-based errors	14	87.5	11	68.8	1.64	N/S
	Decision errors	15	93.8	15	93.8	0.00	N/S

Table 1. Investigative Elements

ological framework for managing investigations was developed. The paper begins by briefly describing the NTSB accident investigation process then presents the Principal Issue Management Model (PIMM), which has been developed to provide the methodological framework for managing investigations. The project is being applied to investigations in all transportation modes, but for the purposes of this paper we are confining the discussion to aviation.

### Major aviation accident investigations

The NTSB is required by law to investigate all civil aviation acci-

dents in the United States. A major accident investigation that involves a large commercial airliner can be complex, fraught with uncertainties about cause, and can result in outcomes of concern to multiple public and private stakeholders. For example, the investigation of the American Airlines Flight 587 accident, where the vertical stabilizer separated from the airplane's fuselage due to the "pilot's excessive and unnecessary rudder inputs" (NTSB, 2004), required 3 years to complete. It produced more than 8,000 pages of documentation and involved 16 investigative groups and numerous representatives from other federal agencies, the airline, the airplane manufacturer, and the aviation community. The investigation resulted in 15 safety recommendations.

The highly complex and unique nature of a major aviation accident investigation requires multiple sources of expertise. As a result, the NTSB uses a party system where relevant stakeholders are part of the investigative team. These participants are usually drawn from the Federal Aviation Administration (FAA), the airline involved in the accident, the manufacturers of the aircraft and aircraft systems, and organizations representing specific entities such as airline pilots or cabin attendants.

The management structure of a major aviation accident is shown in Figure 1. The investigative team is organized into groups, headed by NTSB group chairs, who examine each of the accident areas. As one might expect, the areas are typically divided into topics related to the aircraft, the people (including crew and, when appropriate, air traffic control and maintenance), and the environment. An investigator-in-charge (IIC) is responsible for managing the investigation, and all investigative groups report to the IIC. Parties to

the investigation provide valuable investigative support and information through the group chairs, but typically reside outside the core investigation team and do not participate in NTSB deliberations about findings, conclusions, causes, contributing factors, and safety recommendations. Division chiefs provide management support in each of the operational and technical areas, and senior office management oversees investigative resource requirements and schedules.

Major aviation investigations may take a year or longer, depending upon their complexity. During this time, investigative groups gather and analyze evidence that is used to develop fac-

Data from Eastern Participants (Taiwan)	Pearson Chi-square test			Goodman & Kruskal Tau		Odds ratio
	Value	df	P	Value	p	
Organizational process * Inadequate Supervision	7.27	1	.002	.46	.009	NS
Organizational climate * Supervisory violation	5.33	1	.021	.33	.025	NS
Organizational climate * Planned inadequate operations	6.35	1	.012	.40	.015	21.00
Organizational climate * Inadequate Supervision	16.00	1	.000	1.00	.000	NS
Resource Management * Inadequate Supervision	9.60	1	.002	.60	.003	NS
Supervisory violation * Personal readiness	5.33	1	.021	.33	.025	NS
Planned inadequate operations * Personal readiness	6.40	1	.012	.40	.015	21.00
Inadequate Supervision * Physical environment	7.27	1	.007	.46	.009	NS
Inadequate Supervision * Personal readiness	9.00	1	.003	.56	.004	49.00
Inadequate Supervision * Physical/mental limitation	6.35	1	.012	.40	.015	21.00
Technology environment * Perceptual errors	5.03	1	.025	.31	.030	NS
Technology environment * Decision errors	7.74	1	.006	.47	.008	NS
Personal readiness * Perceptual errors	7.27	1	.007	.46	.009	NS
Physical/mental limitation * Skill-based errors	3.88	1	.049	.24	.050	10.667

Table 2. Types of Principal Issues

tual reports about their investigative areas of responsibility. Ultimately, the factual information generated by these groups is integrated into a final Safety Board accident report. NTSB investigators analyze the facts and produce findings and safety recommendations. The accident report includes the analysis, a list of findings, the probable cause of the accident, and any safety recommendations intended to address safety concerns identified during the course of the investigation.

We have found that every accident investigation is made up of three important elements (shown in Table 1): principal issues, investigative tasks, and data and information.

*Principal issues* are defined as critical aspects of the accident that can explain the accident in terms of *what* happened and *why* it happened. These issues are critical because they can verify important factual information, help to resolve conflicting theories, establish causal or contributing factors, and lead to safety issues that result in safety recommendations. The four types of principal issues are summarized in Table 2. In addition, a principal issue comprises questions that require answers, and these questions drive investigative tasks and evidence gathering requirements. Most importantly, the resolution of a principal issue results in an analytic conclusion. Accordingly, effective management of principal issues is central to our accident investigation model framework. Details of the model framework will be discussed in subsequent sections.

*Investigative tasks* are defined as the actions taken by an investigator to gather evidence to answer questions raised by a principal issue. The type of issue (as shown in Table 1 previous page) determines the goals for these tasks and the evidence required to bring timely closure to that issue. Unfortunately, closure does not occur in a linear fashion, but only after sufficient understanding of the scope and magnitude of an issue has been obtained through investigation. For some tasks (for example, an engine teardown), specific time and resource constraints can be determined, thereby allowing traditional structured investigative methods to be used. For other more open-ended (and more common) investigative tasks (for example, evaluating the effect of fatigue on the aircrew), such constraints are not easily quantified, and the utility of traditional structured approaches is not obvious.

*Data and information* are defined as the evidence gathered as a result of investigative tasks. Investigative tasks generate enormous amounts of information that must be related to principal issues. Critical to the success of an investigation is the need to ensure that the evidence is strong enough to support and defend NTSB's position on an issue. In addition, the evidence must be readily accessible to all involved in the accident investigation.

### Management of the investigation

The management of principal issues, investigative tasks, and data and information can be a challenge in a major NTSB aviation accident investigation.

These challenges arise, in part, because major accidents are rare events, often

involving unique and unprecedented circumstances. In addition, investigators are frequently faced with multiple, competing explanations, unquantifiable and often contradictory information, fluid and interdependent investigative tasks, and multiple stakeholders.

These factors make investigations resource intensive and time consuming, and create specific difficulties in investigative task and information management. Consequently, there appears to be no single approach that can effectively and efficiently manage all facets of an investigation. Even if such an approach were possible, it would be undesirable for the following reasons. First, accident investigations do not follow the traditional linear "waterfall" process that moves from gathering data to analyzing data to formulating a solution. The process actually follows the sawtoothed cyclic pattern described by Conklin (2006) that involves the iterative gathering of evidence to answer specific questions.

Second, the overall goal of the investigation is to understand why the accident happened, determine the probable cause, and identify actions to prevent its reoccurrence. This goal requires a management approach focused on principal issues, separate from the local management of investigative tasks and activities.

Third, limited staffing and resources, coupled with the public's need for a quick, accurate, and defensible resolution, demand efficiency in all aspects of the investigation. The NTSB cannot afford the time and resources of an inflexible, "brute force" approach that exhaustively explores all conceivable avenues of inquiry.

Furthermore, several important characteristics of accident investigations make them especially difficult and complex to manage. The important ones are summarized in Table 3 and are briefly discussed below.

#### 1. Every major aviation accident is essentially unique and novel.

No two aviation accidents are exactly alike, even when accidents appear, on the surface, to be similar. The unique characteristics of each accident may be accompanied by multiple, competing explanations that can involve unquantifiable, and contradictory information. For that reason, principal issues must be extensively investigated in every major accident.

#### 2. Important issues in an accident may not become evident until investigators find answers to why the accident occurred and what action can be



Data from Western Participants (United Kingdom)	Pearson Chi-square test			Goodman&Kruskal Tau		Odds ratio
	Value	df	P	Value	p	Value
Planned inappropriate operations *Technology environment	4.75	1	.029	.30	.025	15.00
Personal readiness * Skill-based errors	5.03	1	.025	.31	.030	NC
Adverse physiological states * Perceptual errors	5.03	1	.025	.31	.030	NC
Adverse mental states * Decision errors	16.00	1	.000	1.00	.000	NC
Adverse mental states * Violations	4.62	1	.032	.29	.037	NC

**Table 3. Characteristics of a Major Accident Investigation Related to Wicked Problems**

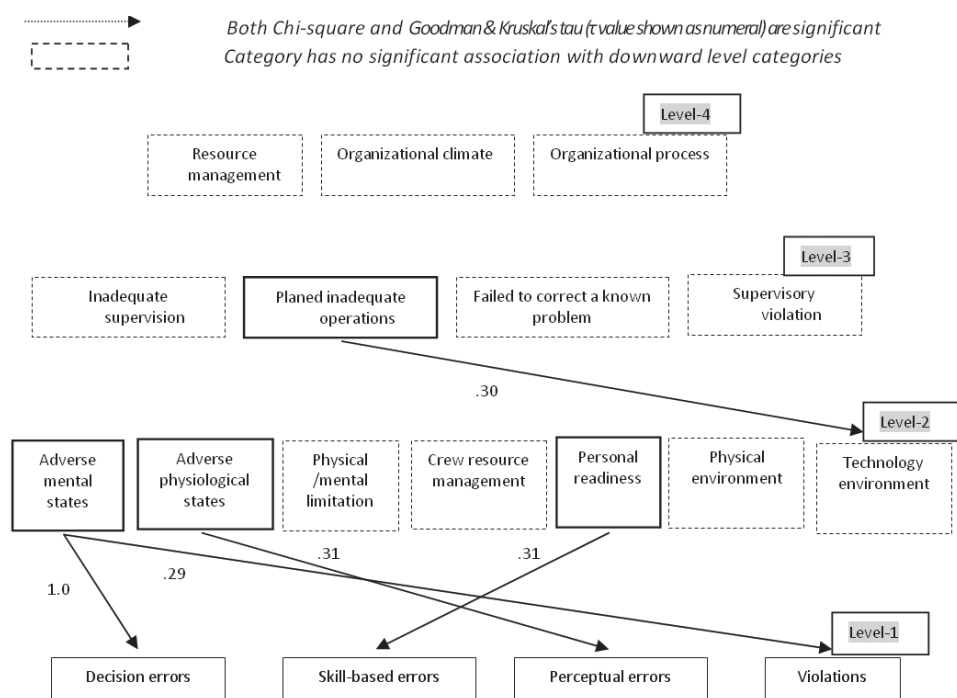

**Figure 2: Principal Issue Management Model (PIMM).**

taken to prevent such accidents. During the process of determining how to take action to resolve a principal issue uncovered in an accident, new aspects of the problem, and the potential unexpected effects of a solution, become evident. In the early stages of a major aviation accident investigation, the scope and magnitude of a principal issue may not be entirely clear. Significant investigative effort may occur before the entire extent of the issue, and the resolution of it, becomes clear. In fact, investigation of one issue may lead to new issues that had not previously been considered in the investigation.

*3. There are no a priori criteria or "stopping rules" for determining when sufficient evidence has been accumulated.*

The unpredictability of what is required to define an issue and generate solutions precludes the use of standard criteria or procedures that set limits to the amount of evidence needed to resolve an issue. This characteristic relates to the previous characteristic, and together highlight why the extent of investigative tasks and evidence-gathering activities, and the resources required to support them, cannot be accurately predicted beforehand.

*4. Conclusions about causes, contributing factors, and safety issues are the best that can be supported by the evidence.*

The quality of the arguments leading to conclusions and recom-

mendations can only be characterized in terms of the strength of the facts and data gathered in the investigation. Conclusions about causes, contributing factors, and safety issues are the best that can be supported by the evidence. Statements unsupported by facts are merely opinion.

*5. Recommendations for actions on safety issues are based on investigators' judgment, expertise, and effective use of evidence.*

Recommendations for action emerging from an investigation are based on investigators' judgment, expertise, and effective use of evidence to support conclusions about principal issues. No *a priori* set of recommendations exists that can be associated with a particular type of accident.

*6. Recommendations may remove a specific hazard, but the overall effect on aviation safety policy will only become clear over time.*

Recommendations to solve a specific problem uncovered in an accident investigation may provide immediate relief from a specific hazard. However, the overall effect of a recommendation, especially one related to systemic problems, may become clear only after sufficient time has passed to evaluate its effects. Given the ever-changing aviation environment, a recommendation may need to be updated

for future applicability.

Note how these characteristics of a major accident investigation focus on in-depth investigation and the role of analysis and consideration of potential solutions in determining the scope and magnitude of an issue. These characteristics imply that solving problems and making decisions are important elements in the investigation, and that analysis begins very early and is crucial to effective progress. In fact, accident investigations have many of the characteristics of a wicked problem (Rittel & Webber, 1973; Conklin, 2006; Ritchey, 2006). In contrast to structured problems, wicked problems are characterized by their complexity, rarity, and uncertain solutions.

The characteristics of a wicked problem are shown in the second column of Table 3. Wicked problems were originally conceived in the context of systems analysis, social policy, and the realization that large-scale problems are not always amenable to classic operations research techniques (Rittel & Webber, 1973). What makes these kinds of problems especially wicked is their resistance to linear, structured solution methods. As Conklin (2006) points out, by "failing to recognize the 'wicked dynamics' in problems, we persist in applying inappropriate methods and tools to them."

As a result, our approach recognizes that management of principal issues, which is at the core of accident investigation, is best

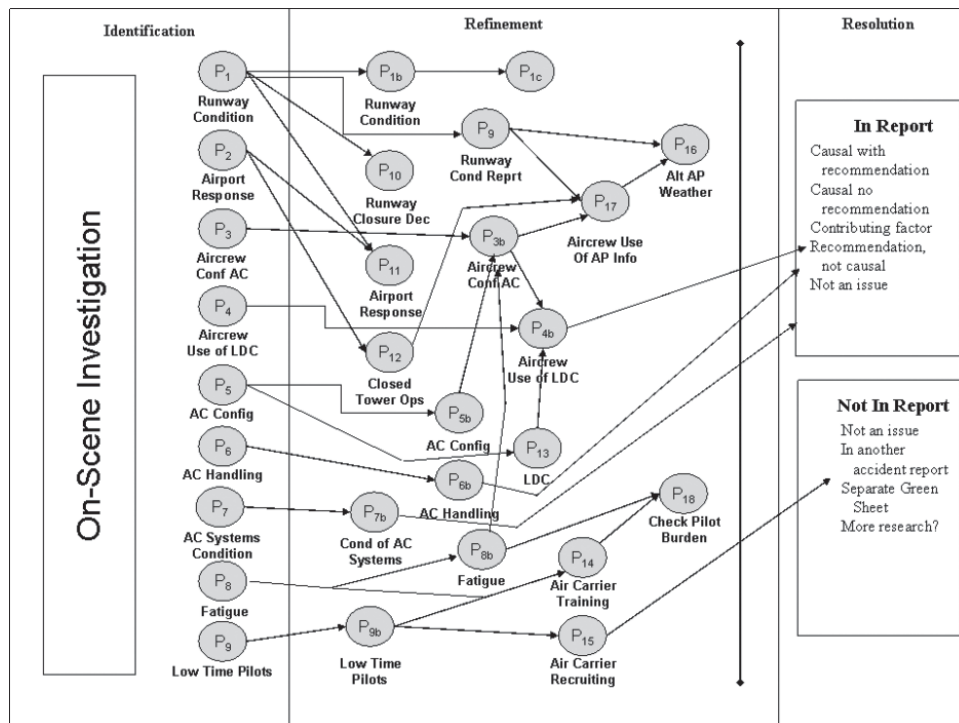

Figure 3: The iterative process of principal issue identification, refinement, and resolution through the course of the investigation.

served by an approach that focuses on the identification, refinement, and resolution of these issues. Accordingly, managing principal issues, rather than managing individual investigative tasks, becomes the foundation for PIMM.

### The Principal Issues Management Model (PIMM)

PIMM is a construct designed to provide the structured management approach shown in Figure 2 (previous page). *Principal issues management* encompasses all the investigative activities concerned with identifying issues, resolving issues, and determining how best to treat the issues in the final analysis and report. If principal issues are defined correctly, then the evidence required to achieve resolution should be readily apparent.

*Task management* is concerned with the investigative tasks used to gather evidence. The goal of these tasks is to obtain the evidence necessary to bring timely closure to a principal issue. As previously discussed, closure does not occur in a linear fashion, but only after sufficient understanding of the scope and magnitude of an issue has been obtained. Considerable investigative effort may be needed to gather the evidence needed to completely understand an issue.

*Information access and control* provides the repository and communications mechanism for the enormous amounts of information generated by investigative tasks and related to principal issues. The evidence must be readily accessible and in a form that can support decisions about an issue. Given the iterative nature of principal issue development, rapid access to evidence at any point in the investigative process is critical. We are pursuing a number of potential solutions to this function including, representations of critical events and sequences, graphical presentation of principal issues and their evolution, electronic bulletin boards, and facilitated team and focused meetings.

Note the division between centrally and locally managed elements of the model.

*Centrally managed* refers to the management, by the core investigation team, of principal issues during the course of the investigation. The core investigative team consists of the group chairs, investigators, and the IIC. Under a centrally managed scheme, all participants are expected to contribute, and all are involved in investigation decision-making. The success of a centrally managed scheme is directly related to the quality and quantity of information related to principal issues. Detailed information that must be gathered and documented for investigation completeness, but is not of direct concern to the principal issues, is locally managed (for example, documenting pilot certificates).

*Locally managed* refers to the management of specific investigative tasks and evidence gathering activities by each investigative group. This group consists of the group chair, the members of the

group, and the appropriate division chiefs. The group chair determines the investigative techniques to employ, and provides documentation of results. At this level, the familiar time and resource demands are evident and dealt with by local management (with appropriate senior office management guidance). The details of these efforts may not be relevant to the core investigation team, and so their documentation and analysis, if required, are conducted with little or no collaboration beyond the local level.

Information access and control becomes a very important interface between the two levels of management. The evidence gathered at the local level is made available to the core investigative team through this interface. These information capabilities are expected to offer the investigative team a data and analysis repository where facts, as well as the analyses and rationale for decisions, are mapped directly to principal issues.

### PIMM structure and function

This section describes the structure and function of PIMM in more detail using a sample accident investigation scenario. The example is not representative of any single accident, but is drawn from a number of similar overrun accidents where a commercial airliner ran off the end of a wet or snow-covered runway.

Figure 3 shows the evolution of principal issues in three distinct phases: identification, refinement, and resolution. The process begins with the initial notification of an accident where NTSB management identifies potential principal issues. This initial assessment dictates which investigative groups will be formed and launched to the accident site. Once on scene, the investigation begins to refine a preliminary set of principal issues. The responsibility for each principal issue is assigned to a specific investigative group. Some principal issues may be associated with more than one group, as indicated by the arrows in Figure 3 showing different groups relating to the same issue.

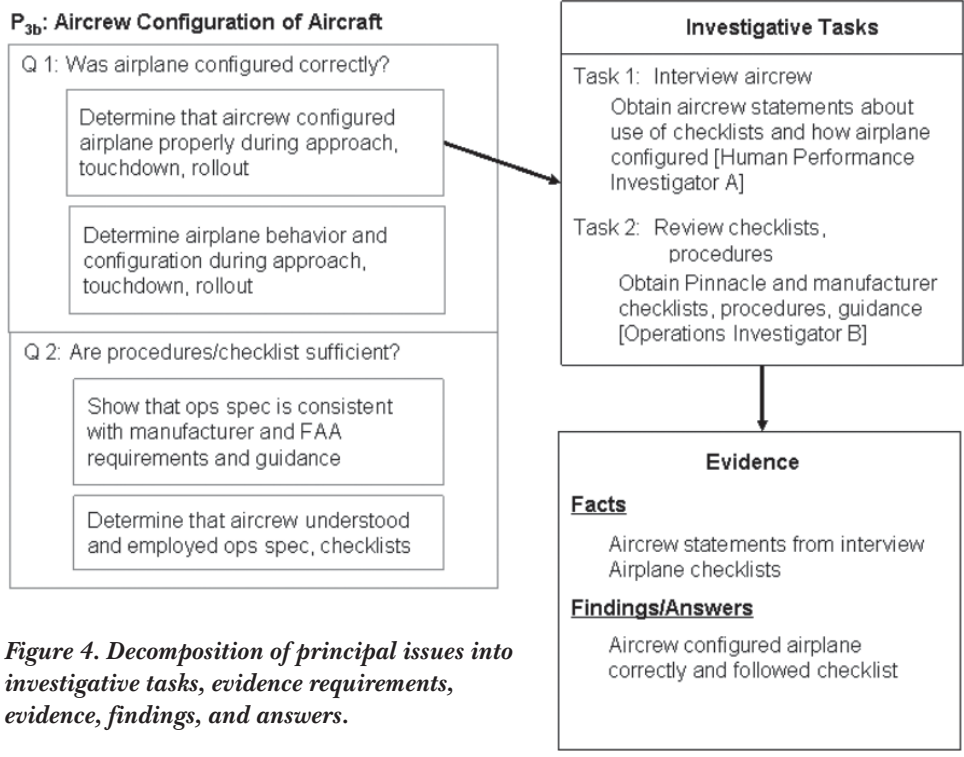

**Figure 4. Decomposition of principal issues into investigative tasks, evidence requirements, evidence, findings, and answers.**

Progression from left-to-right also indicates the relative passage of time during the investigation.

Each principal issue prompts the posing of a few focused questions that define the scope or extent of the issue. Each question has a sufficiency requirement attached to it, which determines what evidence the investigative team believes is required to answer the question. These steps are conducted centrally by the core investigative team for several reasons. First, it is necessary to allow management and investigators to collectively envision and ultimately agree upon the direction of the investigation. Second, developing sufficiency criteria helps ensure that investigative activities are properly balanced with time and effort. As previously discussed, there are no *a priori* stopping rules for determining when sufficient evidence has been accumulated, but criteria must be established to match the level of effort to the burden of proof. Only through deliberation by the core investigative team can sufficiency be determined. Third, the centrally located effort facilitates interaction among the entire investigative team, maximizing input and leveraging collective experience. Finally, priorities can be established and interdependencies among investigative groups can be identified and acknowledged.

Once the principal issues and their associated questions and sufficiency requirements are in place, individual investigators are charged with using their investigative skills and resources to best provide appropriate information, data, or evidence. For example, Figure 4 shows the breakdown of a principal issue—aircrew configuration of the airplane—into its component investigative tasks, evidence, and answers. At this level, the effort is conducted locally by an individual investigator who conducts the tasks and gathers evidence. The emphasis on locally managing these tasks recognizes that investigators are experts in their fields and know best how to gather evidence to resolve an issue. Consequently, the centrally managed goals established for evidence requirements are not proscriptive, but allow individual investigators to determine how best to obtain the necessary

evidence. And it is at this that level traditional project management techniques may be used, if appropriate.

Upon completing a task, the investigator provides principal issue management with a concise analytic discussion of the investigative outcome, along with the necessary factual information, for their consideration. This is a significant departure from current policy and practice, where analysis was assumed to occur only after all the facts had been gathered.

At this point, the core investigative team determines if the principal issue has been resolved. An issue can be resolved in a number of ways, including decomposing a single issue into new, more specific issues, consolidation with other issues, completion and integration into the final report, or determination that the issue is not a concern (and, hence, is not part of the final report). The iterative nature of principal issue refinement and resolution, as shown in Figure 3, is critical to understanding the

accident investigation process. In this process, issues generate specific questions about the accident, and it is these questions that determine the requirements for evidence gathering.

**Additional PIMM benefits**

PIMM can also help organize the final accident report. Report development at NTSB is a major, and very time consuming, part of the investigation. In the past, a dedicated writer was assigned to the investigation near its conclusion. The writer had to gather all of the factual and analytical information from the accident docket and work with the IIC to construct the final report. In some cases, gaps in the investigation came to light as the report was being written. Such situations highlight the need for early identification and documentation of principal issues and the use of a PIMM-like management structure to minimize forgotten issues and incomplete evidence. In PIMM, early involvement of a dedicated writer is important to help ensure that important issues are adequately resolved, and the evidence needed to support conclusions and positions on safety issues is provided. The diagram in Figure 3 shows one of the ways in which the writer and the IIC can monitor progress and see clearly the principal issues under consideration.

PIMM also enables the core investigative team to trace its decision-making process and document the resolution of principal issues. Such documentation is especially important when dealing with sensitive political and public interests that may conflict with the direction and scope of an investigation. Under certain circumstances, especially when an investigation is being challenged, investigators must be able to explain, in detail, the rationale for positions on conclusions and safety issues.

Finally, PIMM is a progress-oriented model intended to minimize investigative backtracking and repetitive decision-making. Too often, issues are repeatedly defined without significant progress. Sufficiency requirements and issue resolution are distinct decision



points where a position on an issue can be established, and progress can be made, especially if further refinement is required.

### Conclusions

Principal issues are central to NTSB accident investigations and drive investigative tasks and evidence gathering activities. Effective management of these issues are critical to verifying important factual evidence, resolving conflicting theories, establishing causal or contributing factors, and identifying safety issues. Effective management can also help overcome many of the problems created by unquantifiable and often contradictory information, multiple and competing explanations, fluid and interdependent tasks, and multiple stakeholders. Such a focus on principal issues acknowledges that solutions to issues uncovered during the accident investigation may be slow to emerge, and require considerable iterative investigation and expert technical input to resolve.

A focus on principal issues, and the analytic thought required to resolve them, is central to other approaches to accident investigation. The Australian Transport Safety Bureau (ATSB) places analysis at the center of its approach (ATSB, 2008; Walker, 2007). Two of the types of principal issues shown in Table 2—safety issues and causal/contributing factors—are similar to the issues discussed by ATSB. In its approach, emphasis is placed on resolving an issue by developing a solution to the safety problem. In contrast, our emphasis is on the upfront problem definition and formulation for all types of issues and setting goals and evidence requirements for investigative tasks. In our approach, investigators focus on understanding principal issues in order to effectively use investigative resources to gather the evidence necessary for successful resolution. Effective solutions to a safety problem come after the scope and magnitude of an issue is understood. As a result, managing principal issues places substantial emphasis on a flexible, nonlinear problem-solving approach.

Such an approach also emphasizes an investigator's problem-

solving skills rather than on the use of a single accident model or method. Although such accident models can be useful in the analysis of a specific principal issue, or perhaps a specific type of accident, the utility of a singular model or method does not become evident until after considerable investigative effort has been expended to understand the issue. In addition, the multidisciplinary nature of a modern major accident investigation precludes the use of a single accident model because it may not be applicable across all technical areas.

In conclusion, we believe that PIMM provides a model framework that enhances investigator problem solving and decision-making by focusing on identifying, refining, and resolving principal issues. By doing so, PIMM provides the basis for analytic thought early in the investigation, for clearly communicating the direction of the investigation, for making visible investigative responsibilities and dependencies, and for establishing sufficiency in tasking and evidence requirements. Such an approach is amenable to a flat management structure that is conducive to participatory decision-making at all levels, and to the rapid exchange of information, while preserving investigators' freedom to explore. ♦

### References

- Conklin, J. (2006). Wicked problems and social complexity. In *Dialogue Mapping: Building Shared Understanding of Wicked Problems* (New York: John Wiley & Sons).
- National Transportation Safety Board (2004). Aircraft Accident Report NTSB/AAR-04/04. *In-flight Separation of Vertical Stabilizer, American Airlines Flight 587, Airbus Industrie A300-605R, N14053, Belle Harbor, New York, Nov. 12, 2001* (Washington, DC: NTSB, 2004).
- Ritchey, T. (2006). Problem structuring using computer-aided morphological analysis. *Journal of the Operational Society*, 57, 792-801.
- Rittel, H. & Webber, M. (1973). Dilemmas in a general theory of planning. *Policy Science*, 4, 155-169.
- Walker, M.B. (2007). Improving the quality of investigation analysis. *ISASI Forum*, January-March 2007, 10-13 & 29.
- Australian Transport Safety Bureau, ATSB Transport Safety Report, Aviation Research Discussion Paper AR-2007-053 *Analysis, Causality and Proof in Safety Investigations* (Canberra city, Australia: NTSB, 2008).

# Weather Risk Management Through a Systematic Approach to the Investigation of Weather Events

By John W. Dutcher, Dutcher Safety & Meteorology Services Halifax, Nova Scotia, Canada, and G. Mike Doiron, Cirrus Aviation Safety Services, Halifax, Nova Scotia, Canada (M04646)



**John Dutcher** heads Dutcher Safety & Meteorology Services based in Halifax, Canada. He has a BSc (aviation) from the University of Newcastle (Australia). John has a Canadian flight dispatcher license, glider, and private pilot licenses. In Australia he has a commercial pilot license (frozen), and has completed Australian ATPL studies. John has taught and guest lectured in meteorology, human factors, risk management, and accident investigation for airlines, insurance companies, maintenance organizations, and governments around the world. In addition to consulting, John teaches a course in applied aviation meteorology in the Master of Aviation Management Program at the University of Newcastle. He also worked as a researcher in the Department of Psychology at Saint Mary's University in Halifax for a number of years on projects in OH&S, safety culture, health care, and decision-making of expert weather forecasters.



**Mike Doiron** heads Cirrus Aviation Safety Services based in Halifax, Canada. Mike graduated from the Transport Canada Air Services Training Centre in Ottawa in 1972. For more than 30 years, he worked for Transport Canada in various roles including the manager of the Halifax Flight Information Centre. In 1996 Mike accepted a position with System Safety, Transport Canada. During this time Mike served as the minister's observer on a number of high profile aircraft accidents, most notable being the Swissair 111 in 1998 and the MK B-747 cargo accident in 2004. Mike also completed a 14-month assignment as an accident investigator with the Transportation Safety Board of Canada. Mike has taught human factors, risk management, and Safety Management Systems around the world including regular commitments for the Southern California Safety Institute (SCSI) and ISASI.

Pilots face many weather-related dangers, enroute and in the airport environment, such as low level wind shear (LLWS), icing, and turbulence. Despite technological advances in weather forecasting, dissemination and presentation of weather-related data, weather continues to be identified, at all levels of the industry, as a contributing factor in aviation occurrences worldwide. Though accidents in the commercial aviation industry (i.e., transport and commuter categories) are rare, an April 2007 report by the International Air Transport Association indicated that 43% of accidents in 2006 occurred during operations in adverse weather (Malaysian National News Agency, 2007). In addition to accidents, weather has a massive impact on the air traffic system, an operator's bottom line, and is responsible for

numerous injuries to flight crews and passengers every year. Just as humans will always make mistakes, weather will always be a contributing factor to aviation occurrences. The question is—to what extent? Can we minimize the number of weather-related occurrences? Can we manage the risk and impact of weather on safety and operations? This paper will advocate the concept of a “weather management system” (WMS) to manage the impact of weather in the operational environment. WMSs represent a more “holistic” approach and are comprised of a series of “weather risk control systems” (Wx-RCSs) designed to manage the impact of weather hazards (e.g., thunderstorms, turbulence, reduced visibility, LLWS) on safety and operations. Wx-RCSs are essentially “mini” Safety Management Systems (SMSs) with all the same components designed to manage weather risks, and enable the broader WMS to be integrated into an operator's overall safety management program (i.e., SMS) as well as influence fuel management policies. A keystone to supporting WMS, and safety improvement in general, is a systematic approach to weather investigations, which produces knowledge derived from information and data gathered during the investigation. By using this knowledge and insight into meteorological conditions, human factors and organizational influences, and technical issues related to weather, investigators will be able to identify risks and vulnerabilities of systems that might cause future occurrences or contribute to their severity. By producing findings of risks and using an WMS framework, weather risks can be analyzed and managed by using various Wx-RCSs in the form of equipment, decision aids, briefing strategies, training, awareness campaigns and materials, proactive forecasting systems, recovery procedures, and clear policies and operational procedures relating to weather and information exchange. Active management involvement, informed working groups, and effective monitoring of outcomes combined with multifaceted approaches that incorporate recent scientific findings and developments in technology can assist the aviation industry reduce weather-related occurrences, improve safety and productivity in flight operations and air traffic management, and reduce its environmental impact through improved fuel management.

## Introduction

Weather has a major impact on the safety, efficiency, and capacity of aviation operations. A 1995 study by the U.S. National Research Council showed 40-65% of delays experienced by U.S. domestic airlines were attributable to adverse weather, at an annual cost estimated at \$4-5 billion per year (NRC, 1995). A more

recent study showed weather accounted for 76% of all U.S. air traffic delays in 2004 (University Corporation for Atmospheric Research, 2005). Weather affects all phases of flight. On the ground, aircraft may have to be deiced before departure, and runways have to be plowed. Lightning in the terminal area prevents ground handlers and fuelers from carrying out their work. Strong surface winds and wind gusts can cause ramp damage by blowing ground servicing equipment into aircraft. During periods of low ceilings and reduced visibilities departing and arriving aircraft are slowed by air traffic control (ATC) thus having a profound impact on runway acceptance rates, often lowered to 75-50% of normal (Qualley, 1997). These delays may necessitate the carriage of extra fuel—which in turn results in higher fuel burns due to increased weight. In regards to the enroute phase of flight, upper level winds (e.g., those associated with the jetstream) and temperatures have a significant impact on fuel burn and on-time performance. Turbulence is also a major concern to passenger carrying flights and military operations (i.e., refueling), with icing, thunderstorms, and volcanic ash also impacting operations with closed air routes forcing costly reroutes (Qualley, 1997) and placing increased workload on controllers to manage the safety of aircraft and traffic flow through the airspace system.

Given recent technological advances in the cockpit, the ATC tower, and developments in weather forecasting, questions arise as to whether weather is “just the cost of doing business” (Dutcher, 2005; Regnier, 2008). Can the aviation community, along with others (e.g., power utilities, marine operations, vineyards, disaster and emergency management organizations), take advantage of these advancements to minimize the negative impact of weather on their operations and enhance their performance even further? These improvements have created the potential for the risk management and human factors communities to have a tremendous impact in distilling weather information into valuable tools to support and enhance decision-making, leading to improvements in safety and operations. By combining meteorology with these seemingly vastly different sciences the greatest potential for impact in the future is in integrating weather forecasts into decision-making, and coordinating activities through strategically directing resources using a risk based, systematic approach aimed at minimizing the impact of weather on operations and safety. As a mechanism to support continuous improvements, a systematic approach to weather mishap investigation is needed. Such a comprehensive approach should be positioned not only to understand the meteorological phenomenon present at the time of the mishap, but also the decisions made in light of the surrounding situation. Armed with this improved understanding, findings of risk and practical recommendations can be made to correct safety deficiencies and further improve performance and support the development of tools and processes. Through integrating these systems into overall safety management program and governing company management systems, improvements can become part of everyday company operating philosophies and practices.

## Background

### *Weather hazards*

Pilots face many weather-related dangers, such as low level wind shear (LLWS), icing, thunderstorms, and turbulence in the enroute and airport environment. Despite technological advances in weather forecasting, dissemination and presentation of weather-

related data, weather continues to be identified as a contributing factor in aviation occurrences worldwide; at all levels of the industry. In the U.S., historically, about two-thirds of all general aviation (GA) accidents that occur in instrument meteorological conditions (IMC) are fatal. Moreover, though weather-related accidents are not frequent, they account for a large number of aviation fatalities—only 6% of GA accidents are weather-related but they account for more than one in four fatalities that occur in GA annually (National Transportation Safety Board [NTSB], 2005). In the commercial airline industry, a 2007 study by the International Air Travel Association (IATA) showed that the 2006 global average hull-loss rate was 0.48 accidents per million flights, or one accident for every two million flights for IATA's member airlines. Though accidents in the commercial aviation industry (i.e., transport and commuter categories) are rare, IATA indicated that 43% of accidents in 2006 occurred during operations in adverse weather (Malaysian National News Agency, 2007).

In addition to accidents, there are numerous injuries to flight crews and passengers due to weather-related mishaps each year. For instance, of all weather-related commercial aircraft incidents in the U.S., 65% can be attributed to turbulence encounters (Sharman, Tebaldi, Wiener, & Wolff, 2006). Further, research at NASA estimates that airlines encounter severe turbulence nine times a month, resulting in an average of 24 injuries per month (Adams, 2001), with major U.S.-based carriers estimating they receive hundreds of injury claims and pay out “tens of millions” per year (Sharman et al., 2006). Encounters with turbulence can also be costly in operational and financial terms. An encounter with severe turbulence may result in significant damage to the aircraft requiring expensive inspections and repairs. Flight deviations, meals and hotels, and passenger inconvenience, not to mention bad publicity, are all rub-off factors to be factored into the real cost of an encounter. Considering these factors, along with litigation, NASA's Aviation Safety program estimates the cost to the airlines from encounters with turbulence runs more than US\$100 million a year (Adams, 2001), with one airline estimating that each encounter of severe turbulence costs an average of US\$750,000 (Collaborative Decision-Making, n.d.).

Besides turbulence, weather events such as the London Heathrow fog event, and the crippling winter storms in Canada and the U.S. in December 2006, to name a few events, have vividly exposed the enormous impact of weather on operations. These types of events can have a swift and grave impact on both an air operator's and an airport's bottom line.

### *Technological improvements*

Given accidents and disruptions in air traffic caused by hazardous weather are magnified by the lack of understanding of weather information (to be discussed later) and an intrinsic uncertainty of weather forecasts a great deal of research and development work, worldwide, has been directed at increasing the accuracy, precision, and reliability of aviation weather forecasts in efforts to improve safety and air traffic management. Many of the improvements in aviation weather forecasting have come from the introduction of complex and advanced technologies (including increased levels of automation) into the weather office. These improvements have been relatively rapid in the weather forecasting domain, particularly over the last 20 years. These changes have come in the form of such technologies as high resolution



satellite imagery, doppler radar, Automated Weather Observing Systems (AWOS), and improved atmospheric computer modeling (i.e., numerical weather prediction [NWP] models).

In addition to the improvements in technology in the weather office, improvements in the observation, analysis, and dissemination of weather-related information has allowed for improvements in aviation safety and performance. Improvements in aircraft radar, the development of the Low Level Wind Shear Alert System (LLWAS), and other technology for the observation of weather can be used to support decision-making and evade hazardous weather. Technologies in the U.S. like the Integrated Terminal Weather System (ITWS) to observe and forecast local thunderstorms using Doppler radar data out to one hour in advance, and the Collaborative Convective Forecast Product (CCFP) to forecast thunderstorms 2/4/6 hours in advance, have been used to improve safety and air traffic flow management. Similarly, improvements in the dissemination and display of weather information will also continue to improve safety. Many national weather services provide a great deal of aviation weather data for pilots and other users via the Internet with more and more pilots using it as their primary, however some their only, source of weather data for flight planning. Aircraft weather radar, the Aircraft Communications Addressing and Reporting System (ACARS) provides crews with weather data on the flight deck. With technologies such as electronic flight bag (EFB), and NASA's Aviation Weather Information (AWIN) Graphical Weather Information System (GWIS) transmitting graphical weather products to the cockpit will further improve safety and efficacy of operations.

#### *Pilot weather training*

The most common factor contributing to weather-related accidents is pilot error, which can be directly coupled to the lack of pilot understanding of the details of their flying environment (Sand & Biter, 1997). A 2002 NASA study (Burian, 2002) involving over a thousand pilots, from students to airline pilots to instructors, revealed a number of alarming findings in relation to pilot's comprehension of weather. The participants, who had an average of 2,140 total flight hours logged (median = 650 hours), were asked to complete a short weather knowledge test. Analysis of results showed participants, in general, performed quite poorly on the weather test. Many pilots apparently lacked operationally relevant weather knowledge and/or had difficulty recalling what was once learned. The study also found that many pilots did not have an accurate perception of their level of weather knowledge, with many rating their mastery of weather better than their actual performance. Pilots at all levels of formal training, but particularly those who were certificated to fly only in visual meteorological conditions (VMC), also generally had difficulty in integrating weather knowledge from across different weather categories (e.g., weather hazards, weather services, weather interpretation, and weather-related decision-making). All participants, visual flight rules (VFR) only pilots in particular, also had difficulty in demonstrating an understanding of the implications weather information has for real flight operations. In addition, pilots at all levels of formal training also had difficulty on items that required them to "decode" information in various weather products (i.e., forecasts and observations) or to read various weather charts. The study also found that all pilots, including many instructors, were unable to select correct answers for VFR

weather regulations questions. Only 44.7% of all pilots were able to correctly identify marginal VFR visibility and ceiling levels, and 45.9% of all pilots actually incorrectly identified IFR visibility and ceiling levels as those that constitute marginal VFR.

This lack of pilot understanding is not surprising when considering the state of weather training. Most civilian primary ground schools in America include a mere 9 hours of weather instruction. U.S. Air Force pilot training consists of 15 hours of formal weather instruction, as compared to 50 or 60 hours in the past, while U.S. Army aviator weather training consists of about 30 hours. (Lankford, 2000). Student aviators and Naval flight officers in the U.S. Navy receive a little more than 2 weeks of meteorology training in their first year of flying, followed by about half an hour of training each year during instrument refresher (Cantu, 2001). Lankford (2000) argues regulations perpetuate this trend. In most countries, regulations only required pilots, from student to commercial pilots, to obtain and use weather reports and forecasts, recognize critical weather situations, and estimate ground and flight visibility. For the most part, only the airline transport pilot certificate requires the applicant to have any serious meteorological knowledge (Lankford, 2000).

In addition to deficiencies in basic meteorology training, despite the many advances in the use of NWP, doppler radar, and satellite imagery over the last 15 years, training in these areas, even at the highest levels and in the most progressive company, is largely absent—though practical and operations-orientated training with these tools would greatly improve safety and efficacy with improved flight planning and decision-making. Similarly, a recent study by Honeywell (Goold, 2008) uncovered deficiencies in weather radar training and understanding, and revealed almost 70% of pilots were dissatisfied with weather radar training. Pointing out that current radars are concerned primarily with weather analysis and avoidance, the study highlighted that proper interpretation depends on a pilot's adequate understanding of weather radar and meteorology. That said, the researchers concluded most operators do not provide initial or recurrent weather-radar training. It was found that most available training takes place on the job with many pilots describing a "trial-and-error experience" and learning from information obtained from other pilots. Such practices may lead to improper radar operating procedures and techniques and further perpetuate a poor understanding of fundamental weather radar concepts, including its limitations. Once again, regulations seem to perpetuate this trend, with the study also revealing there is little incentive for operators to provide such training since regulators do not require it. This is also true of the advances in NWP and other technologies available.

#### *Weather-related pilot decision-making*

Decision-making is a complex process of gathering and processing information in working memory and formulating and implementing a plan of action. Decision-making is fundamental to all aspects of flying operations, including weather. Most research examining weather-related decision-making has focused particularly on understanding why VFR pilots risk flying into deteriorating weather.

One key reason why pilots may decide to continue a VFR flight into adverse weather is that they make errors when assessing the situation. That is, pilots are seen to engage in VFR

flight into IMC because they do not accurately assess the hazard (i.e., the deteriorating weather conditions). A study by Goh and Wiegmann (2001) indicated that pilots with more experience were generally more confident of their ability to recognize problems and to generate and implement solutions. However, contrary to previous research on expertise, results suggested that pilots with more experience did not necessarily feel more confident in their ability to diagnose flight-related problems. The researchers argued that this may be the result of pilots not being trained as thoroughly in diagnostic decision-making processes as are experts in other domains. Yes, pilots are generally trained to detect problems, such as engine failures, but to then rely on checklists and documented emergency procedures to diagnose and resolve the problems. In addition, some checklist procedures even bypass the diagnostic stage altogether and simply require an emergency landing. Goh and Wiegmann (2001) point out that though the necessity to perform diagnostic procedures may be reduced or even eliminated for some inflight problems, other problems such as changes in weather are still important. Therefore, recognizing that the weather has changed does not imply a pilot will generate the most optimal plan to deal with it. Being able to diagnose how serious this weather change is and the options available given the constraints of the situation (e.g., the weather change precludes the option of returning to the origin), are highly important. Consequently, in the event that a pilot encounters situations that are not easily defined in emergency procedures (e.g., inadvertently encountering adverse weather), the pilot will need to rely on his or her own abilities to diagnose the problem quickly and accurately. Results of the research indicated that even experienced pilots did not have an overwhelming confidence in their abilities to accomplish this task as it related to weather (Goh and Wiegmann, 2001). A 2002 study by NASA lends support to this showing that pilots at all levels of formal training, but particularly those who were certificated to fly only in VMC, generally had difficulty in integrating weather knowledge from across different weather categories (e.g., weather hazards, weather services, weather interpretation, and weather-related decision-making) (Burian, 2002). Given the discussion of pilot's training in meteorology, this is not surprising—especially in light that though diagnostic skills are essential they are largely not taught besides the mechanical reading (decoding) of forecasts and observations.

With respects to technology, Wiggins (2005) argues that despite the significant advances in the technology related to the prediction and reporting of weather conditions, the safety and efficiency of a flight remains dependent upon the pilot making an accurate and expeditious decision concerning the impact of the conditions reported. Moreover, in addition to weather reports and forecasts, the pilots of advanced-technology aircraft now have available weather radar systems that display a vast array of weather-related information in real time. It is assumed that the provision of this information has the potential to improve weather-related decision-making by enabling pilots to recognize changes in the weather conditions at a relatively early stage of the flight and thereby take appropriate action. However, as discussed, pilots may lack the confidence and skills to accurately diagnose and assess weather features and make sound and timely decisions. Couple this with the often lack of adequate training in

many of these new technologies and the true value of all the money and effort spent on developing these technologies aimed at supporting decision-making becomes clearer.

### Can we manage the weather?

It can be seen that various initiatives exist to improve aviation safety and air traffic management through the development of technology for the display and dissemination of weather-related information, improvements in observations, and the accuracy of weather forecasts and such projects as the CCFP and ITWS in America. Besides advancements in technology, there is a growing amount of research looking at pilot weather-related decision-making and ways to improve it—though studying VFR flight into IMC appears to dominate these research activities. Also relevant to the “weather problem” is the number of developments in other areas like cognitive engineering, expertise, instructional techniques, and safety management.

However, despite these improvements are we actually doing anything? The answer is yes, but a more pertinent question might be “are we doing enough?” Sure these advances have made significant improvements to aviation, but are we getting the most from them? Are we just “spinning our wheels” if we are designing technology to improve efficiency and safety, but not training people adequately, in some cases at all, on how to use it? We are still landing and taking off aircraft when the terminal area is blanketed with thunderstorms. There are still numerous injuries due to turbulence every month. There are major weaknesses in pilots' understanding of key concepts in meteorology. There are major weaknesses, at all levels, in pilot weather analysis and diagnostic skills, as well as in assessing the impact of weather on the flight. It seems we have reduced the weather problem down to a number of components or silos, but in some respects it appears this reductionism has made us half-blind. It is time to step back from the puzzle and see the whole picture—from 35,000 feet. The systems' view. By looking at the bigger picture we can see potential for overlap. Through identifying the strengths and weaknesses of work in each silo and the potential interplay between them, we can develop a common thread. This common thread will allow for a unified, concerted effort instead of having silos working in isolation. The status quo will have only limited results. The greatest potential for improvement in safety, air traffic management, aircraft operations, and fuel management is in a more unified effort for managing weather.

Another advantage of a systems view is the ability to see how different systems interact. Like human behavior, we cannot control Mother Nature. But through studying human behavior and the relationships between humans, tasks, environment, technology, tools, etc we have been able to realize significant reductions in accident rates. Borrowing from Reason (2000), we cannot change weather; however we can change how we interact with it and making our organizations and operations more “weather tolerant.” By looking at the relationships among weather, technology, human factors, and operations, we can design our interaction for better results. Different system outcomes can be had by building different relationships, sometimes using the very same or similar parts, because small changes to the parts can make a tremendous difference (Vincente, 2003). By applying this same philosophy to weather, we can design relationships with technology, operations, human factors, etc., that will lead to harmony, not tension—good fits, not bad.

## Weather management system

The systems' view is useful for identifying components of a large system of activity and for seeing the interplay between them. Though this will allow for improvements in products, procedures, and technology while having affinity with humans and operations, a mechanism to direct these activities is needed. Staying within the realm of systems-thinking, we must develop a mechanism to strategically direct management strategies to manage weather. From a different view we can further break the weather problem down into system components and examine the interplay between them. Using a risk-based approach we can identify deficiencies and areas of risk and then direct activities to manage these risks by prescribing help from the various products and programs developed as a result of a greater cooperation between silos (e.g., weather displays that are built upon governing principles of human-computer interaction [HCI]). By using a risk-based approach, these systems can be integrated into other management activities (e.g., company management, safety management, air traffic management, fuel management) as well as allow for everyday use and industry implementation using a common framework. Borrowing from occupational health and safety management systems (OHSMS) theory (International Labour Office [ILO], 2001) and recognizing that like fatigue, ramp damage, maintenance error, etc., weather is a source of risk that also needs to be managed using a "weather management system" (WMS), which focuses activities to maximize results. In essence, coordinating and focusing activities using a WMS is working at the intersection of meteorology and the science of risk management to improve relationships and consequently safety and performance.

A WMS, like an OHSMS and Safety Management System, is a systematic approach to managing weather. It applies techniques used to manage other aspects of business performance such as quality and safety. This approach is based in General Systems Theory (input, process, output, and feedback). Unlike a prescriptive program (e.g., federal regulations on pilot training, VFR and

IFR flight minimums), a WMS does not focus solely on compliance with regulations; it takes a broader perspective and aims for continuous improvement. A WMS is a risk-based approach aimed at managing risks effectively through systematically identifying hazards (e.g., winter weather, LLWS, thunderstorms, fog), assessing and controlling risks (i.e., disruption to operations, fuel wastage, death, injuries), and evaluating and reviewing risk control measures to ensure that they are effectively implemented and maintained. A WMS strives for continuous improvement, which can be achieved by monitoring system effectiveness and taking action to improve the system where required. This active monitoring means that organizations can address weather issues and system failures even before an accident occurs.

Borrowing again from guidance on OHSMS by the ILO (2001), a WMS has five main elements (see Figure 1) that follow Deming's (1986) internationally accepted Plan-Do-Check-Act (PDCA) cycle. These five elements are policy, organizing, planning and implementation, evaluation, and action for improvement. "Policy" contains the elements of "weather policy" and employee participation. It is the basis of the WMS as it sets the direction for the organization to follow. "Organizing" contains the elements of responsibility and accountability, competence and training, documentation and communication. It makes sure that the management structure is in place, as well as the necessary responsibilities allocated for delivering the weather policy. "Planning and implementation" contains the elements of initial review, system planning, development and implementation, weather-related objectives and hazard prevention. Through the initial review, it shows where the organization stands concerning weather, and uses this as the baseline to implement the weather policy. "Evaluation" contains the elements of performance monitoring and measurement, investigation of injuries, damage to aircraft, and disruption of services as a result of weather, audit, and management review. A WMS shows how the larger management system functions and identifies any weaknesses that need improvement. It includes the very important element of auditing, which should be undertaken for each stage. "Action for improvement" includes the elements of preventive and corrective action and continual improvement. It implements the necessary preventive and corrective actions identified by the evaluation and audits carried out. It also emphasizes the need for continual improvement, of weather-related performance through the constant development of policies, systems and techniques to prevent and control weather-related occurrences, injuries, and negative impact on the efficacy of operations.

### Weather risk control systems

The broader WMS contains a number of smaller "weather risk control systems" (Wx-RCSs) designed to manage the impact of a weather hazard (e.g., thunderstorms, turbulence, reduced visibility, LLWS) on safety and operations (Dutcher, 2005). A Wx-RCS is essentially a "mini" SMS with all the same components designed to manage weather risks, and enable the broader WMS to be integrated into an operator's overall safety management program (i.e., SMS) as well as influence other areas connected to weather, like fuel management policies and air traffic management.

Part of the output of a Wx-RCS is risk controls or types of defenses that prevents a hazard from creating harm (i.e., preven-

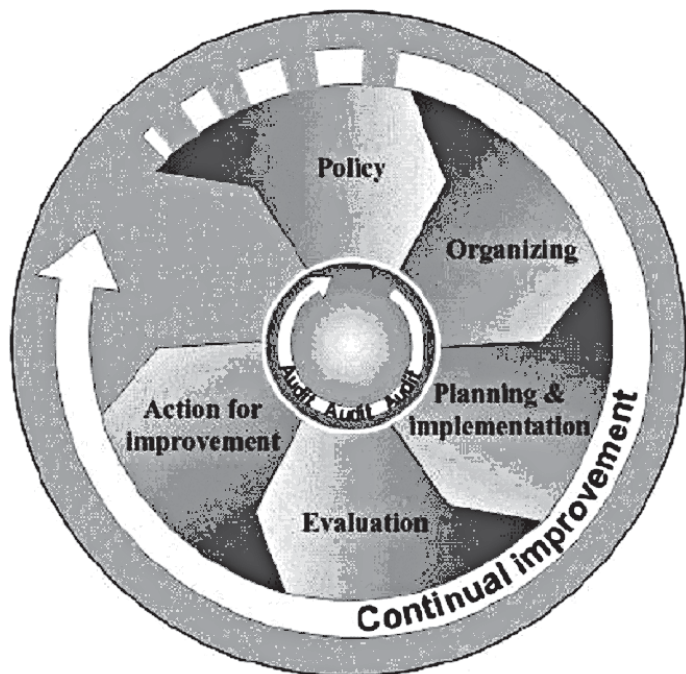

Figure 1. Main elements of a weather management system.



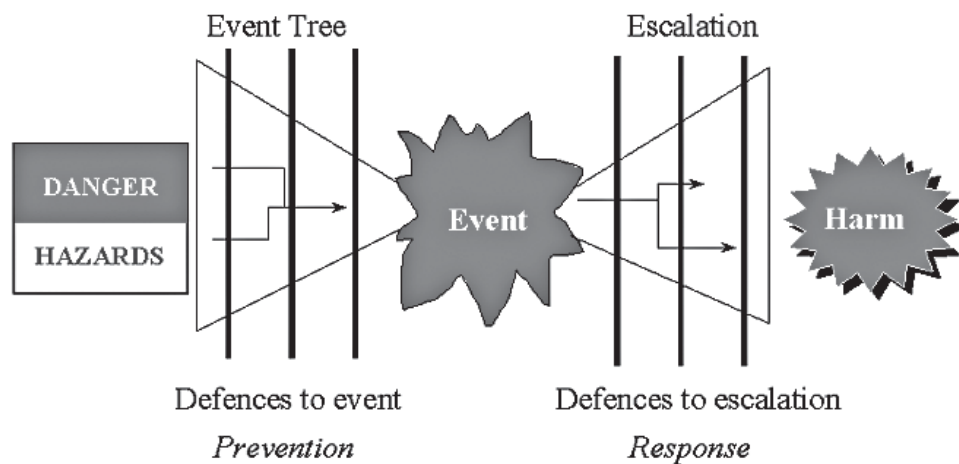

Figure 2. Bow-tie Model

tive controls) or mitigates the harm once an event has occurred (i.e., recovery controls). Defenses can be categorized into three different types—

- *Engineering defenses.* Physically prevent a hazard from causing harm such as deicing fluid or other “engineering fixes” like outfitting aircraft with weather radar.
- *System defenses.* Control hazards by specifying procedures to be followed, such as a company policy regarding operations near thunderstorms, LLWS recovery procedures.
- *Human defenses.* Actions, competence, and expertise that are required by individuals to prevent hazards from being realized in the first place. For example, a pilot’s ability to recognize and diagnosis echoes on weather radar is a human defense that prevents planes from flying into thunderstorms.

As part of prescribing risk controls, it is important to identify risk controls that can be put in place to prevent or reduce the likelihood of an undesirable event occurring (that is, preventive controls), and risk controls that can be put in place to minimize the consequences of the undesirable event (that is, recovery controls) (Australian Transport Safety Bureau [ATSB], 2008). Given both types of controls are important for maximizing safety a useful tool for this type of analysis is the ‘Bow-tie model’ (see Figure 2) (Reason, 1997).

#### *“Defenses-in-depth”*

The terms “defenses-in-depth” or “lines of defense” are used to refer to the notion that there are generally a number of risk controls providing layers of protection in a transport operation. Each layer of risk controls provides assurance against the possible breakdown in the preceding layer. Reason (1997) noted that deficiencies in defenses or risk controls can occur due to individual actions or to systemic problems (for example, being poorly designed in the first place). At any particular time in any safety system, there will be weaknesses in some risk controls, and these weaknesses will change over time. These holes or weaknesses can occasionally align, leading to serious consequences (ATSB, 2008, page 41). Like humans, defenses are not perfect, thereby necessitating several layers of defenses. If one defense fails the hazard still may not cause harm because other defenses are in place. The number of defenses in place will depend on the level of risk posed by a specific hazard. High hazard activities (e.g., landing in bad weather) require multiple redundant systems, for example

weather radar, instrument landing system (ILS), and ILS procedures, to reduce the risk of an accident.

#### **Investigation of weather-related occurrences**

To allow for lessons learned, occurrences must be comprehensively investigated to determine if weather was a contributing factor to the occurrence. Investigations must include gathering and plotting atmospheric data to establish the state of the atmosphere at the time of the occurrence, as well as identify weather hazards (e.g., icing, LLWS,

lightning, turbulence) that may have played a role in the occurrence. Though it is important to understand what meteorological conditions and phenomena influenced the aircraft, it is also important to understand decisions made by pilots, controllers, dispatchers in relation to the weather. Such an analysis may highlight issues with pilot or dispatcher incorrect and/or incomplete knowledge due to training deficiencies, and/or poor dissemination of weather data, or incomplete weather data due to reporting limitations.

That said, to simply say a pilot flew into bad weather does little to explain why. A key question is “Why did it make sense at the time?” Through “reverse engineering” investigators can gain an understanding of the systemic connections between human behavior and features of the tasks and tools that the people worked with, and of the operational and organizational environment in which they carried out their work. By gaining a comprehensive understanding of the evolving situation in which people’s behavior took place, investigators will be better suited to understand the behavior (Dekker, 2002). To facilitate this, a systematic approach to weather investigations must look at the mishap from, obviously, a meteorological perspective identifying the weather conditions and phenomena that may have played a contributing role in the mishap but also from a technical and human factors and organizational perspective. Understanding the context in which humans err is fundamental to understanding the unsafe conditions that may have affected their behavior and decision-making. These unsafe conditions may be indicative of systemic risks posing significant accident potential.

#### *Meteorological perspective*

To allow for a comprehensive examination of weather data, the investigator must utilize a methodological approach, allowing examination of data in the vertical (i.e., surface, 850/700/500/250 millibar levels) and the horizontal (discussion to follow).

#### *Analysis funnel*

The “analysis funnel” is built upon Orlandi’s (1975) notion of scaling, which is essential to establishing the importance of various processes in the atmosphere. Primarily, for the purpose of weather investigation, there are three size scales (largest to smallest): planetary (or hemispheric), synoptic, and mesoscale (see Figure 3). Given most energy transfer in the atmosphere is downscale from the planetary scale, analysis should begin there, gradually working downscale and inward toward the smallest scale.

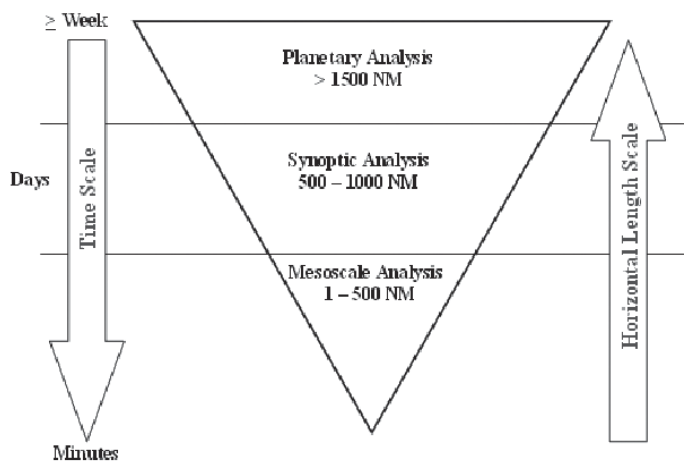

Figure 3. Analysis funnel (above).

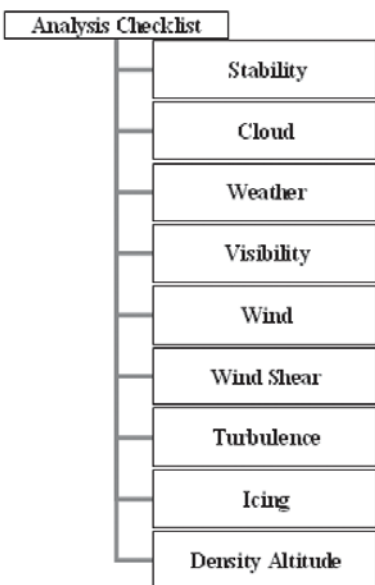

Figure 4. Weather analysis checklist, (left).

This framework essentially forms an analysis funnel providing an investigator with a comprehensive understanding of the state of the atmosphere and interrelation of scales (Dutcher, 2004). In other words, this will provide an understanding of why the weather did what it did at the local level as a result of the interplay between local factors (i.e., topogra-

phy, bodies of water, local stability, water, and air temperatures) and the larger scale dynamics (i.e., highs, lows, frontal systems, jetstreams, upper level troughs, ridges, and vorticity, thermal advection). Essentially, this provides the “why” of the weather.

*Weather analysis checklist*

From analysis of research and various aircraft accidents and events Dutcher (2003, 2004) developed the “weather analysis checklist” (WAC) to provide a sound analytical framework to assist in identifying flight conditions and possible weather hazards present (see Figure 4). The WAC is structured to allow a logical flow for analysis, moving downward from stability—since stability determines virtually every subsequent factor. Moreover, many of the items in the checklist are influenced by the preceding item. For instance, an unstable atmosphere will allow for the formation of towering cumulus and cumulonimbus clouds resulting in thunderstorms and rain and consequently reduced visibility. Additionally, the unstable conditions can cause surface winds to become variable and gusty. With thunderstorms comes the presents of windshear associated with downbursts (e.g., microburst) as well as turbulence. The strong vertical currents inside the towering cumulus and cumulonimbus clouds combined allow for the rapid growth of large water droplets representing a significant icing threat above the freezing level. Warm temperatures can create high-density altitude conditions that can have a major impact on

aircraft performance. In addition, thunderstorms can also cause erroneous altimeter readings.

In addition to a structured framework for analysis, the WAC is also useful as a tool to provide for a clear summary of conditions at each scale, allowing others to follow the logic of the investigator. Following the comprehensive analysis of all scales (as per the analysis funnel) with regard to the weather analysis checklist, the four-dimensional understanding of the atmosphere must be related to each phase of flight to determine if, and what, weather hazards were present during (a) taxi, takeoff, to top of climb; (b) enroute; and (c) top of descent, approach, landing, and taxi.

By combining the analysis funnel with the WAC, an investigator can systematically identify weather hazards at every phase of flight and be able to explain “meteorologically” why the weather behaved in such a manner. In other words, this identifies the “what,” “where,” “when,” “how,” and “why” of the weather.

*Technical factors*

In addition to examining the weather-related occurrence from a meteorological perspective, investigators must also consider technical factors that may have restricted the accuracy and comprehensiveness of meteorological data provided to aircrews, ATC, and operators. In some cases investigators may breakdown and test meteorological instrumentation if the accuracy of weather data is suspect. In cold climates, during winter, ice can form on meteorological instrumentation and is thus a possible consideration during an investigation. For instance, during periods of freezing precipitation, ice accretion may reduce the efficiency or cause complete failure of anemometers, restricting the validity of wind data. These same considerations may be applied to aircraft instrumentation as well as the affect of temperature and density changes on altimeters.

Technology for gathering and displaying weather information must also be examined to understand the capabilities and limitations of such tools (i.e., radar technology, high-resolution zoom satellite imagery). Consideration must also be given to possible limitations of technology as a result of atmospheric phenomena—for instance, aircrews flying into thunderstorms and areas of hail as a result of false radar returns caused by radar attenuation due to absorption.

*Human factors and organizational issues*

Comparison of forecast conditions, aircrew actions, and the investigator’s identification of possible hazards may suggest possible issues with aircrew judgment. However, simply stating that the pilots flew into adverse weather conditions does little to explain why. Investigators must endeavor to identify why the aircrew’s decisions made sense to them at the time. Were there human-factors-related barriers to effective aircrew weather decision-making—for instance, lack of knowledge due to inadequate training or poor provision of weather data, and operating norms?

The overall process of occurrence investigation within the human factors field is similar across many methodologies. However, differences arise in their particular emphasis of the techniques. While some focus on management and organizational oversights and omissions, others consider human performance/error problems (on the frontline) in more depth (Livingston, Jackson, & Priestley, 2001). With that said, both levels must be examined to gain a comprehensive understanding of how such things

as organizational norms and policies impacted decisions and behaviors, and how organizational structures influenced the communication of weather information and consequently decisions.

### **Adequacy of service**

Emphasis should be placed upon determining whether the crew was adequately informed regarding hazardous weather conditions. The observing, forecasting, and briefing facilities involved and the services provided should be examined with a view to determining whether such things as whether pertinent regulations and procedures were satisfactory, available, and adhered to; that forecasts and briefings were accurate and made effective use of all known and relevant information; and communication of information to the relevant aeronautical personnel was accomplished without delay and in accordance with prescribed procedures.

### **Adequacy of flight documentation and messages**

In some countries, frequently observed local weather effects at an aerodrome may be listed in flight supplements data as a warning to aircraft. These flight supplements are often used for flight in VMC. However, these same warnings may be silent in documents relating to flight in IMC for the same aerodrome. Therefore, comparison of such documents should be made so as to highlight possible disparities. As an example, a flight supplement for an aerodrome surrounded by rough terrain with frequently strong winds may warn of possible mechanical turbulence given certain conditions (i.e., wind direction and speed). However, this warning may be silent in approach plates used in IMC. In addition, investigators must also consider the possibility that frequent use of these particular aerodromes may breed complacency and thus non-use of such documents even in VMC.

Aside from flight documentation, consideration to messages in flight must also be given, for instance significant meteorological information (SIGMET) messages. Such data should be examined for clarity and brevity and whether they facilitated understanding and use of messages given conditions of flight. This may also include the "cognitive ergonomics" of weather displays and messages (e.g., HCI considerations). In addition, the possible limitations of reports such as with pilot reports (PIREPs) must also be considered. These limitations are particularly relevant to reports of icing and turbulence given their interpretation is subjective (e.g., Bass, Kvam, & Campbell, 2002).

### **Operating norms and policies**

Norms, whether organizational, group, or individual, may significantly influence behavior and operations. In relation to weather, an investigator must analyze the various organizations, groups, and norms of the aircrew (if possible). Particular attention should be paid to norms and policies relating to the dissemination of information and analysis of data. For instance, a possible norm of pilots failing to read dispatch reports in their entirety due to their considerable length. This norm of seeking only certain data may have restricted the comprehensiveness of weather briefings provided. In addition, federal regulations and operator's operational policies regarding flight in hazardous weather conditions and the operational reality should be analyzed for disparity. Such analysis may also be applied to industry norms, e.g., penetration of thunderstorms in terminal areas (Rhoda & Pawlak, 1999).

### **Individual proficiency**

Investigators must also give consideration to the proficiency of individuals (i.e., pilots, dispatchers, controllers). Borrowing from Rasmussen (1982), there may be issues with academic and operational knowledge of meteorology and perhaps the limitations of the aircraft and technology. In addition, there may be deficiencies in skill of personnel in interpretation of products and application of data. In addition to identifying deficiencies, it is equally important to uncover why they exist. In other words, are these deficiencies the result of inadequate training and dated knowledge? Furthermore, an investigator should also consider the possible influences of workload and pressure (either real or perceived) on errors and decision-making of individuals and crews.

### **The role of systems theory in accident interpretation**

The most important question in an investigation is "why?" Occurrences are seldom the result of a single cause. Although individual factors when viewed in isolation may seem insignificant, in combination they can result in a sequence of events and conditions that result in an accident. Systems theory is the study of the interaction of people, their tools, equipment, materials, facilities, procedures, software, and work environment and how they work to accomplish a common goal. Using a systematic approach to investigating a weather occurrence from a meteorological, technical, and human factors perspective allows an investigator to identify various conditions and factors that played a role in the event. However, it offers little about the dynamic interplay between the various factors and the conditions that allowed events to transpire. In order to gain this understanding, we must again step back to see the bigger picture and make sense of it using various models of systems thinking like Reason's "Swiss cheese" model (1990) and the SHELL model (Edwards, 1972; Hawkins, 1987). Having assessed the interplay between factors, an investigator can identify deficiencies and systems failures and produce findings of risk and make recommendations as to how to manage these risks (i.e., risk controls). Therefore, the results of a weather investigation can be used as input into a WMS to allow for continuous improvement.

### **Conclusion**

Weather has a significant impact on safety, air traffic management, fuel burn, and on-time performance. In response to calls for improvement, several initiatives now exist to improve aviation safety and air traffic management through the development of technology for the display and dissemination of weather-related information, improvements in observations and the accuracy of weather forecasts and specialized forecast products. Besides technological advancements, research continues to grow into pilot weather-related decision-making, cognitive engineering, expertise, instructional techniques, and safety management. However, despite these improvements, weather continues to be a contributing factor in many accidents. In some instances we are designing technology to improve efficiency and safety, but not training people adequately, in some cases at all, on how to use it. We are still landing and taking off aircraft when the terminal area is blanketed with thunderstorms. There are still numerous injuries due to turbulence every month. And there are major weaknesses in pilots' understanding of meteorology and training. It appears a unified, concerted effort to focusing efforts is



needed as the status quo will have only limited results. The greatest potential for improvement in safety, air traffic management, aircraft operations, and fuel management is in a more unified effort for managing weather using a systems view. By using a WMS, we can strategically direct management strategies to manage the risk and impact of weather hazards (e.g., thunderstorms, turbulence, reduced visibility, LLWS) on safety and operations.

It can be seen that though we cannot control or change weather, we can actually do something about it. Weather is *not* “just the cost of doing business.” By studying the relationships among weather, technology, human factors, and operations we can change how we interact with weather thus improving safety and performance and making our organizations and operations more weather tolerant. ♦

## References

- Australian Transport Safety Bureau. (2008). *Analysis, causality and proof in safety investigations*. (Aviation Research and Analysis Report AR-2007-053). Canberra, ACT: Author.
- Adams, C. (2001, August). Tackling Turbulence. Defense Daily Network. Retrieved March 24, 2005, from [http://www.defensedaily.com/cgi/av/show\\_mag.cgi?pub=av&mon=0801&file=0801cat.htm](http://www.defensedaily.com/cgi/av/show_mag.cgi?pub=av&mon=0801&file=0801cat.htm).
- Bass, E.J., Kvam, P., & Campbell, R.H. (2002). Measuring the Seat of the Pants: Commercial Airline Pilot Turbulence Assessments in a Full-Motion Simulator. *International Journal of Aviation Psychology*, 12, 123-136.
- Burian, B.K. (2002). *General Aviation Pilot Weather Knowledge*. (FAA Grant #00-G-020). Moffett Field, California: NASA Ames Research Center.
- Cantu, R.A. (2001). The Role of Weather in Class A Naval Aviation Mishaps, FY90-98. Unpublished Master of Science in Meteorology and Physical Oceanography thesis. Monterey, CA: Naval Postgraduate School.
- Collaborative Decision-Making (CDM). (n.d). Severe Turbulence and Severe Icing. NAS Status Information Subgroup Memo. Unknown, United States of America: CDM. Retrieved March 24, 2005, from <http://cdm.metronaviation.com/de/nasdocs/nasdata/Turbulen.rtf>.
- Dekker, S. (2002). *The Field Guide to Human Error Investigations*. Cranfield, UK: Cranfield University Press, Ashgate.
- Deming, W.E. (1986). *Out of the Crisis*. Cambridge, MA: MIT Press.
- Dutcher, J.W. (2005, November-December). Heavy Weather. *Civil Aviation Safety Authority, Australia, Flight Safety Australia*, 9 (6), 40-41.
- Dutcher, J.W. (2004). Weather Investigation. In *Aircraft Accident Investigation Manual-Part 3*, Chapter 5—Aircraft Operating Environment Investigation. Montreal, Canada: International Civil Aviation Organization. (pp. III-5-1 – III-5-11) (in press).
- Dutcher, J.W. (2003). *Weather Analysis Checklist for Aircraft Accident Investigation*. Retrieved June 15, 2008, from <http://www.johndutcher.com/wxinvestigation.html>.
- Edwards, E. (1972). Man and Machine: Systems for Safety. In Proceedings of the BALPA Technical Symposium, London.
- Goh, J., & Wiegmann, D.A. (2001). Visual Flight Rules Flight into Instrument Meteorological Conditions: An Empirical Investigation of the Possible Causes. *International Journal of Aviation Psychology*, 11, 359-379.
- Goold, I. (May 1, 2008). Honeywell: Better wx training needed. Retrieved June 10, 2008, from <http://www.ainonline.com/news/single-news-page/article/honeywell-better-wx-training-needed/>.
- Hawkins, F.H. (1987). *Human Factors in Flight*. Aldershot, UK: Gower Technical Press.
- International Civil Aviation Organization (2006). *Safety Management Manual (SMM)*. Montreal, Canada: ICAO.
- International Labor Office (2001). *Guidelines on Occupational Health and Safety and Health Management Systems*. Geneva, Switzerland: ILO.
- Lankford, T.T. (2001). *Aviation Weather Handbook*. New York, USA: McGraw-Hill.
- Livingston, A.D., Jackson, G., and Priestley, K. (2001). *Root Causes Analysis: Literature Review*. Suffolk, UK: HSE Books.
- Malaysian National News Agency (2007, April 17). IATA Calls for Further Improvement in Air Travel Safety Record. Retrieved April 17, 2007, from <http://www.bernama.com.my/bernama/v3/news.php?id=257166>.
- National Research Council. (1995). *Aviation Weather Services: A Call for Federal leadership and Action*. Washington, DC: National Academy Press.
- National Transportation Safety Board. (2005). *Risk Factors Associated with Weather-Related General Aviation Accidents*. (Safety Study: NTSB/SS-05/01). Washington, DC: NTSB.
- Orlanski, I. (1975). A Rational Subdivision of Scales for Atmospheric Processes. *Bull. Amer. Meteor. Soc.*, 56, 527-530.
- Qualley, W.L. (1997). Impact of Weather on and Use of Weather Information by Commercial Airline Operations. Paper presented at the *Workshop on the Social and Economic Impacts of Weather*. Boulder, Colo. April 2-4. Retrieved June 12, 2008, from <http://sciencepolicy.colorado.edu/socasp/weather1/qualley.html>.
- Rasmussen, J. (1982). Human Errors: A Taxonomy for Describing Human Malfunction in Industrial Installations. *Journal of Occupational Accidents*, 4, 311-333.
- Reason, J. (2000). Human Error: Models and Management. *British Medical Journal*, 320, 768-770.
- Reason, J. (1997). *Managing the Risks of Organizational Accidents*. Aldershot: Ashgate.
- Reason, J. (1990). *Human Error*. Cambridge Univ. Press: Cambridge, UK.
- Regnier, E. (2008). Doing Something about the Weather. *International Journal of Management Science*, 36, 22-32.
- Rhoda, D. A., & Pawlak, M.L. (1999). An Assessment of Thunderstorm Penetrations and Deviations by Commercial Aircraft in the Terminal Area. (Project Report NASA/A-2). Springfield, VA: NTIS.
- Sand, W. R., & C. J. Biter. (1997). Pilot Response to Icing: It Depends! Paper Presented at the *7th Conference on Aviation, Range, and Aerospace Meteorology*. Long Beach, CA. Feb 2-7. American Meteorological Society, Boston, MA.
- Sharman, R., Tebaldi, C., Wiener, G., & Wolff, J. (2006). An Integrated Approach to Mid- and Upper-Level Turbulence Forecasting. *Weather and Forecasting*, 21, 268-287.
- University Corporation for Atmospheric Research (2005). Impact of Weather on Air Traffic Management-Section 3: How Weather Impacts the NAS. Retrieved January 24, 2006, from <http://meted.ucar.edu/nas/print3.htm>.
- Vincente, K. (2003). *The Human Factor: Revolutionizing the Way We Live with Technology*. Toronto, Canada: Random House of Canada.
- Wiggins, M. (2005). *The Interpretation and Use of Weather Radar Displays in Aviation*. (Aviation Research Investigation Report). Canberra, ACT: Australian Transport Safety Bureau.

# An Attempt at Applying HFACS to Major Aircraft and Railway Accidents During the Period from 2001 to 2006 In Japan and Some Problems Analyzing Results

By Yukiko Kakimoto, Ph.D., NPO Aviation and Railways Safety Promotion, Tokyo, Japan



*Yukiko Kakimoto worked as a research psychologist at the Aeromedical Laboratory, JASDF, Defense Agency. She then became a professor at Kagoshima Prefectural College (1997-2000) and Jissen Women's University (2000-2007). A member of the Aircraft and Railways Accident Investigation Commission (2001-2007), Dr. Kakimoto is now working at NPO Aviation and Railways Safety Promotion, Tokyo, Japan. Dr. Kakimoto has been a Fellow member of the Aerospace Medical Association in the U.S. since 1987.*

## Introduction

Two major accidents in which more than 100 persons were injured or killed occurred during the period from 2001 to 2006 where the author worked as one of members of the Aircraft and Railways Accident Investigation Commission in Japan. One was a near midair collision (B-747 vs. MD-10, on Jan. 31, 2001) and the other was the railway's derailed and crash accident (JR West, Fukuchiyama Line, on April 25, 2005). In the near midair collision, nine persons were seriously injured, and 91 persons were slightly injured. In the railways derailment and crash, 107 persons were killed, and 562 persons were seriously injured.

In Japan, commercial airlines have maintained the zero record of fatal accidents since 1985. In near midair collision, this was not a fatal accident, but it has been 16 years since there has been more than 100 persons injured. It had been 43 years since a railway accident has had more than 100 passengers killed and nearly 600 passengers injured.

Why did these accidents occur? A trial was done using HFACS (Human Factors Analysis and Classification System) and SHEL models based on released accident investigation reports.

## Background of aircraft accidents

Aircraft accidents statistic were reviewed for background information. During the period from 1974 to 2007, a total of 1,215 aircraft accidents occurred. The distribution ratio of aircraft accidents was commercial airliners 11.3%, general aviation 27.70%, ultralight planes 12.1%, helicopters 32.8%, gyroplanes 1.9%, gliders 14.2%, and airships 0.2%. Among these, general aviation and helicopters had high incidents of accidents (Table 1). The distribution rate of aircraft accidents during 2001-2006 had a similar

trend, except for gliders (Table 2). Commercial airliners 11.36%, general aviation 28.9%, ultralight planes 11.3%, helicopters 27.5%, gyroplanes 1.4%, and gliders 19.7% were shown. Causes of aircraft accidents during the periods from 1974 to 2006 were attributed to pilot errors 69.3%, inadequate maintenance 2.4%, materials 9.7%, weather 0.8%, others 17.3%, and unknown 0.4% (Table 3). Among "others," communication errors by air traffic controllers were included. Distribution of pilot errors were quite different by type of aircraft as follows—in commercial airliners 25.0%, general aviation 75.0%, ultralight planes 76.9%, helicopters 69.8%, gyroplanes 82.6%, and gliders 83.3%. The distribution of pilot errors as accidents causes (2001-2006) were as follows—airliners 18.8%, general aviation 80.5%, ultralight planes 81.3%, helicopters 53.8%, gyroplanes 100%, and gliders 78.6%. Commercial airliners had a low occurring rate of accidents and a lower contribution by pilot errors.

## Models for human factors approaches

When our Commission met about near midair collisions—the railways derailment and crash and many other accidents, special human factors models were not used, but we always discussed why the accident occurred. From the early 70s era, the word of human factors has existed. Since that, many approaches have been discussed—4M4E, 5P, or 6P approaches; FTA, 3W approaches by the U.S. Army; SHEL, mSHEL, FTA, VTA, HFACS (revised Reason's Swiss cheese model (Shappell, S.A., and Wiegmann, D.A., 2001), and FRAM (Hollnagel, E., 2006).

The HFACS model has been used frequently since 2001 in presentation papers in safety session at the annual scientific meeting of the Aerospace Medical Association. Dr. Wen-Chin Li and Don Harris (2006) revealed the relationship between pilot errors and the organizational factors using 523 Republic China Air Force pilots. In this study, an attempt was carried out to apply HFACS to major accidents (including one railways accident) and applying HFACS to general aviation and helicopter accidents to compare with major accidents.

## Methods

Based on released accident reports between the period 2001 and 2006, HFACS was used for two previously described major acci-

dents and HFACS was applied to general aviation and helicopter accidents, picking up some accidents caused by human errors. The distribution ratio of accident occurrence was nearly 30% in both general aviation and helicopter accidents. These are high ratios compared with other types of accidents.

Simultaneously, the SHEL model was used to consider preventive actions. Concerning the SHEL model, a management factor was added to the main four factors and became mSHEL.

The reason the mSHEL model was used was because it was difficult to develop preventive measures from the results of the error classification.

## Results

### 1. Near midair collision

#### Outline of the accident

On Wednesday, Jan. 31, 2001, a Japan Airlines (JAL) B-747-400 departed Tokyo International Airport as scheduled passenger Flight 907 to Naha Airport. The aircraft was climbing through an altitude of approximately 37,000 ft per climb instructions from the Tokyo Area Control Center (ACC) when it began descending to an altitude of 35,000 ft in response to an instruction from Tokyo ACC. On the same day, a JAL Douglas DC-10 departed Pusan International Airport in South Korea as scheduled passenger Flight 958 to New Tokyo International Airport. In accordance with its flight plan, the aircraft was cruising at an altitude of 37,000 ft over the Shima peninsula, Aichi prefecture, heading toward the Oshima VORTAC navigational fix having cross the Kowa VORTAC navigational fix.

Around 15:55, the two aircraft experienced a near midair collision and took evasive actions at an altitude between approximately 35,500 ft and 35,700 ft over the sea about 7 nautical miles (about 13 km) south of Yaizu NDB, Shizuoka prefecture. Passengers and flight attendants on board Flight 907 sustained injuries as the result of the evasive maneuvers.

Of the 427 persons aboard Flight 907—41 passengers, the captain, and 15 other crew members—7 passengers and 2 cabin attendants were seriously injured, and 81 passengers and 10 cabin attendants sustained minor injuries. The interior of the passenger cabin of Flight 907 was slightly damaged due to the upset, but no fire occurred.

There were 250 persons on board Flight 958—237 passengers, the captain, and 12 other crew members—but there were no injuries. There was no damage to Flight 958.

This accident was triggered because a trainee air traffic controller instructed Aircraft A to descend to 35,000 ft. The trainee intended to instruct Aircraft B to descend to 35,000 ft but made a mistake in B's call sign and instructed Aircraft A.

#### HFACS analysis

- Unsafe act (Level 1): An ATC trainee (ATCt) instructed aircraft A to descend to 35,000 ft. Instead of aircraft B's call sign, he communicated aircraft A's call sign. Skill-based error.
- From aircraft A, the readback came immediately; however, the ATCt and his supervisor (ATCs) did not notice ATCt's mistake of the call sign.
- ATCs instructed aircraft A to climb to Flight Level 350, but this instruction was too late because aircraft A had already begun to descend per the ATCt's instruction.
- ATCs intended to instruct aircraft B to descend, but the ATCs

made a mistake regarding B's call sign.

- The supervisor instructed to use a call sign that any aircraft in flight had not used at that time.
- ATC coordinator noticed the ATCt's initial call sign mistake regarding aircraft A, but he didn't advise the ATCt.
- Precondition (Level 2): Until CNF symbol was indicated, the trainee and his supervisor might have momentarily forgotten the presence of aircraft B. They were shock and tried to correct the mistake in a hurry.
- Psychological factor: Just before the CNF was displayed, the ATCs explained the traffic flow to the trainee. Before this explanation, the trainee concentrated on contacting aircraft C because it was cruising at the altitude of 39,000 ft he that he assigned to aircraft A. However, he could not contact aircraft C even though he tried for several times. Psychologically, it is supposed that they were upset because of forgetting momentarily the presence of aircraft B and became panicked.
- Supervisory problems (Level 3): Was it a suitable time during the trainee's on-the-job training to explain the traffic flow? Did the supervisor have enough education as a supervisor? When the CNF was displayed, why did the supervisor change the trainee position?
- Organizational problems (Level 4): There weren't any education programs for ATC supervisors during on-the-job training.
- On the ATC radar scope, it is requested to display the TCAS TA and TCAS RA together with the cockpit display.
- In this accident, the CNF was displayed 56 seconds before the near midair collision occurred because the aircraft was turning. It was requested to display the CNF on the radar although the aircraft was turning or performing attitude changes.
- Kanto South C sector in this accident is the busiest area in Japan. It is requested to reconsider distributing the airspace.

#### Preventive actions using mSHEL model

L: ATC trainee needs to continuously brush up on his skills and to reevaluate the situation.

The trainee and the supervisor needed to understand how TCAS works.

The ATC supervisor needs to master teaching techniques for OJT trainees.

L-H: On the ATC radar scope, it is requested that TCAS information is displayed simultaneously with cockpit. (Under the current system, the radar scope was improved.)

Concerning CNF, it is requested that it be displayed on the radar 3 minutes before the near midair collision even if the aircraft is turning or performing an attitude change.

L-H-L: When there is a contradiction between an air traffic Controller's instruction and TCAS RA instructions, pilots need to follow TCAS RA instruction. (As a recommendation, the Commission of Aircraft and Railways Accident Investigation, Japan proposed this to ICAO in 2002. This recommendation was adopted in 2004).

### 2. Major railways accident—

#### JR West Fukuchiyama Line derailment accident

##### Outline of the accident

On Monday, April 25, 2005, the rapid up train 5418M for Doshisha departed from Itami station at 09:16:10 and passed Tsukaguchi station at 09:22. The train was running on the radius



304 m right turn curve; the first car derailed about 09:18:54, then second, third, fourth, and fifth cars derailed and finally the seventh car stopped at 09:19:04'. The first car rolled to the left and crashed against the wall of the parking lot by the first floor of the apartment building on the corner of the line.

The second and third cars crashed into the posts of the apartment houses. The fourth and fifth cars were derailed. The sixth and seventh were not derailed.

In this accident, 107 persons (including a driver) were killed, and 562 persons received injuries.

The trigger of this accident was speeding and delay in braking by the driver.

#### HFACS analysis

- Unsafe act ( Level 1): The driver did not decrease the train speed until the deceleration point at the beginning of the radius 304 m right curve. Skill-based and decision error.
- Precondition (psychological condition): His attention might have been concentrated on listening to the communication between the conductor and an upper instructor. At the previous Itami station the driver made an over run about 72 m beyond the stop point. The driver asked the conductor to report to the upper instructor that the driver overran less than 50 m. The driver was afraid to be punished by the director for his over run as he received some punishment for his over run near 100 m a few months ago. Usually an over run under 50 m does not necessitate punishment.

The driver tended to concentrate on the communication because he had not yet gotten the conductor's response for his proposal as the conductor was very busy with work. The driver wanted to know how the conductor informed his overrun to the upper instructor.

- Supervisory factors: Under the name of education, drivers are punished. Regarding education, enhancement of performance was not involved, but unrelated punishment.
- Organizational factors (Level 4): In the organization, a safety culture had not grown. Top managers made the first priority the benefit of the company, not on safety. On this Fukuchiyama line, new ATS systems were not completely built.

#### Preventive actions using mSHEL model

L: If the driver was alive, it would be suggested he master the skill of braking.

L-H: As the new ATS was not settled, the over speed was not prevented.

L-S: It is necessary to have preventive procedures for over run.

L-m: Education for the person who made a human error was not enough. Human factors education is recommended to prevent accidents.

Compared with the results of major accidents, HFACS was used for the following general aviation and helicopter accidents using accident data regarding human errors.

#### 1. No gear landing because of forgetfulness

##### Outline of accident

##### (1) Nov. 19, 2002, 10:24, Nagasaki airport, Beechcraft type

During a trainee training, when the instructor pilot wanted to do gear down on the downwind of Runway B, the air traffic controller instructed to the pilot to extend down wind and wait by turn-

ing right at the A hill because a commercial airliner was approaching. The instructor replied they didn't want to turn to the right because of simulated left engine trouble, and the instructor requested to go to Runway A by crossing Runway B with a higher altitude than the commercial airliner. At the gear down point of Runway A, the instructor was very busy advising his trainee, to avoid the mountain and the jet stream of the commercial airliner, etc. The instructor completely forgot to put the gear down.

##### (2) May 26, 2004, 15:08, Ami Airport, Beechcraft type

Returning from Sendai to Ami Airport, Ibaragi prefecture, the captain hurried to land at the airport. He felt tired. On the downwind of Ami Airport, he once tried to gear down, but he changed his action and wanted to gear down on final approach. When he made his final approach, he saw the sinking sunlight in front of the window of the cockpit. Trying to avoid the direct the sunlight, he completely forgot put the gear down.

#### HFACS analysis

- Unsafe acts ( Level 1): Forgetting to put gear down. Skill-based error.
- Psychological Precondition (Level 2): In both cases, attention was placed on other things except the landing gear.
- Supervisory factor (Level 3): Not related.
- Organizational factor ( Level 4): Not related.

Both cases occurred as a result of the human characteristic "inadequate attention."

#### Preventive action

L-S: Use landing checklist and not to depend on memory checklist.

L-H: Develop the system of putting landing gear down automatically.

L-L: Not related.

L-E: Not related.

L-m: Not related.

#### 2. Crash accidents while on photographic missions

##### Outline of the accidents

##### (1) Jan. 22, 2004, 10:29, a Cessna crashed in Kofu city, Yamanashi prefecture

In order to take photographs of children at their preschool as a memory of their anniversary, the captain tried to approach the preschool. On the sixth approach, the Cessna did not recover from low altitude and low speed. The captain, an instructor, and a camera person were killed.

##### (2) Aug. 16, 16, 2001, 09:58, Cessna, Okayama prefecture

To take photographs of a new house of a farmer, the captain and two camera persons tried to take photos from the slope of a mountainous area. The Cessna did not recover from low altitude, a sharp left turn, and low speed and crashed into a rice field.

Three persons were killed.

#### HFACS analysis

The analyses of the two cases were carried out together as they were very similar accident patterns.

These accidents were related to lack of concentration.

Unsafe act (Level 1): Delayed recovery from low altitude and low speed. Delay in decision-making.

Psychological condition (Level 2): Concentrated attention on the target (objects of photos) and high motivation to take photos for their business.

Supervisory factors (Level 3): In case (1), an instructor on board was late in advising the time to recover.

Not related in case (2).

Organizational factors (Level 4): High priority for business, and low priority for safety.

Safety management was not enough in these flight companies.

### Preventive actions

L: Both pilots had 10 years' flight experiences and more than 2,000 flying hours. The pilots needed to focus on safety motivation and no follow the camera person's requests.

L-L: (pilot vs. camera persons): The pilots must reject the camera person's request even if they were business related when safety is at risk.

L-H: Not related.

L-S: Safety management rules are needed for business and timing of recovering.

L-m: The company needs to manage safety and realize that safety is always a high priority.

### 3. Helicopter accidents

During the period 2001 to 2006, helicopter accidents caused by inadequate communication between a pilot and workers on the ground occurred five cases. Among these, one person died and two had serious injuries. The three accidents follow.

#### Outline of the accidents

##### (1) Oct. 22, 2001, 15:20, Fuji Bell, Sapporo city, Hokkaido

While transporting materials needed for building a park in the suburbs of Sapporo city, a helicopter pilot picked up materials (about a 1,000 kg bag of stone, wood, iron, etc.) and then put it down at the work site. During the 59th time of putting down the bag of materials, the pilot picked up the ground worker who was putting out the materials bag. Soon the pilot and a maintenance person noticed they picked up the worker by the hook of the sling, so the pilot tried to put the man down on the ground. However, the worker's body tended to hit the rock wall. The worker kicked the rock wall to protect for himself and he dropped from the height of 5 meters onto the ground. He had serious injuries. The pilot and a maintenance person on board misunderstood his gesture to "pull up the bag, all right." The worker slipped backward at the time and his left hand raised upward without his intention. This meant "climb, all right." In this flight, the pilot and the worker could not communicate directly. Through relay points, they communicated indirectly.

##### (2) Aug. 20, 2005

While transporting materials needed for making a walking road in the mountain, the pilot was approaching the spot to put down a net with materials (about 800 kg).

When the pilot noticed a worker who was standing on the ridge walk fell down on the ground, it was suspected the worker on the ridge walk was hit by the net. The worker died. In this flight, a maintenance person was not on the helicopter and stayed in the spot where materials were packed. In this case, the pilot and the worker on the ridge walk could not communicate

directly. There were three relay points but one-way communication.

##### (3) Oct. 18, 2005, Unaduki, Toyama prefecture

While transporting materials needed to build a bridge in a deep valley, a pilot put down the materials on the bridge and they hit the worker on the bridge.

The worker was injured on his right leg. The accident occurred on the seventh time the materials were put down. When the materials were first put on the bridge, they were not put in the exact position so the worker requested via a maintenance person on board that the pilot move to the left a little. The pilot moved to the left little by little, but the materials hit the worker's right leg. Non-verbal gestures were used in this accident.

### HFACS analysis

The three cases had similar patterns and were analyzed together. Unsafe act (Level 1): Pilots could not see the movement of the workers on the ground and could not hear their voices directly. Perceptual errors.

Precondition (psychophysiological condition) (Level 2): The pilots became exhausted by repeated and frequent tasks of picking up the materials and putting them down in inconvenient and dangerous places.

Supervisory factors (Level 3): Not related.

Organizational factors (Level 4): The safety system between pilots and workers on the ground side was not sufficient. Communication was not sufficient. Helicopter pilots and the workers on the ground could not communicate directly, but they did communicate through two or three relay points.

### Preventive action using mSHEL model

L-H: Improving communication devices was recommended.

L-m: Safety management was suggested to make the environment safer and to maintain adequate communication among different job groups.

### Discussion

To take into account human factors, the HFACS model was used to analyze two major accidents first and then was used to analyze general aviation and helicopter accidents. They were then compared to the two major accidents. HFACS was very useful in developing a human factors approach and easily attained the Level 4 organizational factors in most of cases. While analyzing the results, some questions came up.

1) Concerning unsafe acts, many persons were involved in the accident. For example, in the case of the near midair collision, there were five persons related to the accident—an ATC trainee, an ATC supervisor, an ATC coordinator in the next seat, pilot A, and pilot B. Wanting to figure out the accident visually, the accident related persons were asked on parallel and time sequentially to follow their behaviors. By figuring out the accidents, the resolving points (preventing key points) might be shown clearly. Through analyses of HFACS, it might be difficult to figure out the accidents related persons on parallel and time sequentially.

2) On the other hand, when applying HFACS to general aviations and helicopter accidents, something related to attention, for example, forgetting to use the landing gear, we Level 4 was not attained. These accidents related to human characteristic might finish at Level 2.

However, in the case of crashed because of taking photos, Level 4 organizational factors were adopted smoothly. In helicopter accidents, supervisory level was not related because the pilots had responsibility for themselves and they had no supervisors. Some cases attained Level 4 organizational factors, but some cases could not attain Level 4. It depended on the situations and contents what levels they attained both in general aviation and helicopter accidents.

3) When preventive measures were discussed, the SHELL model (in present paper, management m was adding the four factors) was used because it was difficult to combine countermeasures directly to the results of the classification. Through the cases, the mSHEL model rather clearly identified where unsafe acts or unsafe condition existed and preventive measures needed to be built up.

## Conclusion

Within limited case analyses, I conclude

1. Without regard to major or minor accidents, aircraft or railway accidents, commercial airliners or general or helicopter accidents, the HFACS model is applicable and useful in most cases, but some cases are partially applicable depending on the contents of the accidents.
2. It is difficult to figure out visually how many people are related to the accidents on parallel and time sequentially.
3. It is also suggested to select each model freely depending on the contents of the accidents.
4. To establish preventive measures, the mSHEL model was applied as one trial. However, it is necessary to develop the bridge between preventive measures and the results of analyses. ♦

*Table 1. Aircraft Accident Occurrence Rates (1974–2007)*

	Commercial Airliners	General Aviation	Ultra Light Plane	Helicopter	Gyroplane	Glider	Airship	Total
Number	137	336	147	398	23	173	2	1215
Percent	11.3%	27.7%	12.1%	32.8%	1.9%	14.2%	0.2%	100.0%

*Table 2. Aircraft Accident Occurrence Rates (2001–2006)*

	Commercial Airliners	General Aviation	Ultra Light Plane	Helicopter	Gyroplane	Glider	Airship	Total
2001	2	5	2	8	0	4	0	21
2002	4	4	5	15	0	7	0	35
2003	2	10	3	1	0	2	0	18
2004	4	11	2	6	1	3	0	27
2005	1	8	0	7	0	7	0	23
2006	3	3	4	2	1	5	0	18
Total	16	41	16	39	2	28	0	142
Percent	11.3%	28.9%	11.3%	27.5%	1.4%	19.7%	0.0%	100.0%

*Table 3. Aircraft Accidents Causes Including All Types of Aircraft During the Period 1974-2006*

Causes	Pilot errors	Inadequate maintenance	Materials	Weather	Others	unknown	Total
All type	826	29	116	10	206	5	1192
	69.3	2.4	9.7	0.8	17.3	0.4	100.0%
Airliner	33	3	4	5	87	0	132
	25.0	2.3	3.0	3.8	65.9	0	100.0%
General Aviation	250	9	31	2	38	0	333
	75.0	2.7	9.3	0.6	11.4	0	100.0%
Ultra Light	110	3	20	0	10	0	143
	76.9	2.1	14.0	0	7.0	0	100.0%
Helicopter	273	10	55	1	50	0	391
	69.8	2.6	14.1	0.3	12.8	0	100.0%
Gyroplane	19	1	2	0	1	0	23
	82.6	4.3	8.7	0	4.3	0	100.0%
Glider	140	3	4	2	19	0	168
	83.3	1.8	2.9	1.2	11.3	0	100.0%



# Conversations in the Cockpit: Pilot Error or a Failure to Communicate?

By Noelle Brunelle, H-53/S-61 Product Safety Team Lead,  
Sikorsky Aircraft Corporation, Stratford, Conn., USA



*Noelle Brunelle is the H-53/S-61 Product Safety Team lead at Sikorsky Aircraft Corporation. She has 20 years' experience in aviation, including crew station design and evaluation, airfield management, and air traffic control, and she holds commercial and instrument airplane ratings. She is currently a masters candidate in the human factors and systems program at Embry-Riddle Aeronautical University with a focus on cognitive and social psychology. Noelle is a past recipient of the Rudy Kapustin Memorial Scholarship.*

A crew hears an aural warning but fails to recognize that it signals an oxygen system malfunction. A warning light is perceived as a false alarm when an engine fire actually exists. During a cascading event, dozens of advisories, cautions, and warnings are displayed to the crewmembers, making it difficult for them to correctly diagnose the emergency. What do these three situations have in common? Each involves a breakdown in communication between aircraft and the crew.

The automation installed in today's advanced aircraft has assumed the role of a crewmember. This automated crewmember is responsible for monitoring aircraft status and advising the pilot(s) of the status of the system. This paper will explore the conversations between the automation and the crew: how aircrew mental models are developed, maintained, and used to support situational awareness and decision-making, current display philosophies, and challenges to effective communication between aircrew and the aircraft. The author will also propose a method for evaluating these conversations so investigators may provide feedback to designers to improve these interfaces.

Communication serves many functions—to transfer information, to develop relationships, to predict behavior, to coordinate tasks (see Reference 1). Communication occurs on many levels, ranging from impulses sent between molecules or cells to messages transferred between human actors and objects in their environment. Communication begins when a message is transmitted and continues through receipt, interpretation, and response. Every moment, millions of signals are communicated to us through sight, sound, taste, touch, and smell. Due to the sheer volume of these inputs, we are unable to process every message we encounter. To compensate for the perceptual, cognitive, and memory limitations of the human mind, each of us utilizes a system of goal-driven internal representations to recognize, interpret, and store these messages and use them to navigate the world around

us. These internal representations are known as mental models (see Reference 2).

Mental models (also known as cognitive models or schema) are developed as we explore the world around us. When we first encounter an object, symbol, task, or situation, we focus our attention on the larger elements of its structure. Over time, we discern more details, such as size, use, construction, and context. Tasks become subconscious, and key elements are arranged in patterns for retrieval at a later time. As our knowledge matures, details needed to anticipate future behaviors are added to our overall system models. Well-developed mental models of the flight environment allow expert pilots to detect and place environmental elements and detect both emerging trends and the absence of anticipated signals. When like or similar events are encountered again, these models are activated and guide behaviors and expectations. The robustness of these models is affected by the amount and quality of the information communicated during our experiences, with each repetition reinforcing the links between cues (see References 3, 4).

The development of mental models used by pilots begins long before the current flight. Knowledge and habits are communicated from instructor to student during training. These interactions result in a framework of behavior and expectations that underlie each subsequent flight. This framework influences preparation for a flight including the type of information sought, the methods used to obtain this information, the depth of the information sought and the expectations and goals assigned to a flight. Once a flight has begun, pilots maintain their mental models by performing a methodical scan of the outside environment, the flight instruments, powerplant/drivetrain instruments, and the status of any utility systems. Information displayed by the cockpit indications is cross-checked with cues from the external environment, as well as the sounds, smells, and vibrations generated by aircraft and are integrated into a representation of the current status of the flight. The current status of flight is then cross-referenced with previous indications and compared to predetermined expectations and goals to forecast the future status of the flight. In the early stages of a flight, these mental models can be closely aligned with actual events but the models naturally diverge over time.

In aviation, the use of mental models is commonly referred to as "situational awareness" or "SA."

According to one researcher (Endsley—Reference 4), situational awareness is composed of five elements: geographical, spatial/temporal, system, environmental, and tactical. Geographical SA refers to maintaining awareness of one's aircraft and its relation

to other features such as terrain, airports, waypoints, or other aircraft. Knowledge of a flight's relationship to elements of space such as attitude, altitude, heading, and projected flight path and elements of time, such as velocity and estimated arrival times, are classified as spatial-temporal SA. System SA consists not only of an awareness of the settings, status, and functions of aircraft systems but also the impact of a subsystem degradation or malfunction of the overall system on a flight. Environmental SA is concerned with weather and regulatory environments; tactical SA includes the understanding of aircraft capabilities in reference to a task and mission timing and status. Situational awareness is maintained with communications among a pilot, the aircraft, the environment, and other crewmembers.

Multicrew aircraft (or multi-aircraft flights) requires crewmembers to maintain equivalent mental models. This shared awareness includes representations of the goals and expectations of the flight, the flight environment, aircraft systems and capabilities, other actors (ATC, enemy forces), aircrew responsibilities (both individual and team), and the status of required inflight tasks. Indoctrination training provided by a company or service is used to develop shared mental models of behaviors and expectations. Reinforcement of these models continues through pre-flight actions designed to coordinate goals and individual responsibilities (see Reference 5). During flight, these shared mental models are used to plan and coordinate actions and evaluate the progress of the flight. Crew mental models are maintained by communication. Crew resource management (CRM) was developed to enhance the sharing of information among crewmembers (see References 4, 6).

In traditional cockpits, pilots monitored dials and meters to maintain awareness of system status. Over time, computers have assumed monitoring and control tasks previously performed by pilots. Course guidance, once accomplished by pilots flying a manually selected bearing to a station, is now performed by computers using satellites to triangulate an aircraft's position and execute a pre-programmed routing. Engine and fuel controls previously actuated by the pilot have been replaced with computer-controlled engines programmed to optimize thrust, fuel burn, and speed. Terrain, weather, and traffic information can be integrated into displays, providing increasingly detailed representations of the external environment. Control of today's computer-based and monitored systems is provided by avionics management systems or digital cockpits. As automated cockpit systems assume tasks previously performed by human crewmembers, these digital systems are increasingly being included in the definition of cockpit crew (see Reference 7).

In a digital cockpit, communication between cockpit crew and aircraft systems is accomplished via multifunction displays (MFD) and flight management systems (also known as control display units). Multifunction displays are full-color liquid-crystal displays (LCDs) installed on the instrument panel that use symbols, text, and graphics arranged on formatted pages to communicate the status of selected aircraft and environmental parameters to the crew. Flight management systems consist of an alphanumeric keypad and dedicated keys coupled with a color LCD screen to provide an interface for crews to direct the operation of navigation, communication, and utility systems (see Reference 8). To mitigate the potential for miscommunication, the presentation of information on these displays follows common guidelines.

Dynamic data may be presented in dial or tape or graphic or textual form. Clockwise motion of a dial and upward movement of a tape signify an increase, while graphic information (such as attitude indications) is provided with a recognizable reference to the environment or system they reference. Color is used to supplement, differentiate, or attenuate symbols or cues; green identifies normal operating ranges, amber indicates that a limit is being approached or a system is degraded, and red indicates that a limit has been exceeded or a system is inoperative. The size of numerical and textual symbols is selected to allow them to be read in the normal operating environment; an increase in font size indicates an escalation of events (see References 9, 10). Transient alerts, such as warnings, cautions, and advisories, are normally presented when pilot action is required, when a system is approaching a limit, or when the information is not normal for the current aircraft configuration. Designers may also elect to advise crews of a change in system status and when the automation is performing a corrective action to enable them to predict future system behavior. Alerts may be grouped by function, priority, or sequence of occurrence. These rules are communicated to users by the operating instructions and are reinforced over time as experience with the system increases.

Despite the use of standardized presentations and symbology, challenges to effective communication between aircrew and automation exist. Before a decision can be made, the need for a decision must be recognized, but change is not always easy to detect. When a signal is closely aligned with the observer's field of vision, it is easy to see-presenting a signal as little as 2 degrees from fixation reduces detection to as little as 20 to 40% of the time (see Reference 11). Focusing on a task can affect the detection of unrelated cues. Research exploring the failure to detect a visible cue (inattention blindness) showed that only 54% of participants were able to detect an unexpected event while performing a vigilance task (see Reference 12). We also anticipate trends will continue; research into the phenomena of change blindness (the inability to detect changes to a display while attention is diverted) demonstrated that changes that occurred during eye movements (saccades) were detected correctly on the first try only 71% of the time (see Reference 13). Attenuation, including pairing a visual signal with an audio cue, can increase the probability a signal will be detected.

Once change is detected, mental models are used to guide the response to an event. Research has shown complex problems are solved utilizing the conscious or subconscious matching of patterns (see Reference 3). Thus when encountering an unusual situation, an individual attempts to match the current situation to one experienced before. If this is not possible, previous experiences are evaluated for their relevance to the current situation. If no clear matches can be found, a random search for solutions is used (see References 3, 14). Matching is driven by signals (stop cues) that trigger a known pattern (see References 5, 14). Events indicated by clearly defined alerts or that include cues that have been encountered previously can be quickly matched with existing mental models, increasing the opportunity for crews to utilize established checklists or procedures to resolve the situation. When ambiguous cues are present, pattern matching becomes more difficult. Infrequently displayed cues or those without a clear message can delay comprehension of a message. Unexpected or ill-defined cues generate the search for patterns and can increase

the likelihood that cognitive processes such as satisficing (choosing the first option that meets minimum matching criteria) and confirmation bias (affirming prior interpretations by discounting or dismissing conflicting information) both of which may delay or prevent the correct assessment of a situation (see References 6, 15). Previous “social” interactions may make otherwise clear indications ambiguous; less emphasis is placed on an alert known to have false indications, while a highly reliable alert reduces monitoring of the indicated parameter (Reference 16). Choices made early in an event impact the choices available as the event unfolds, and the longer it takes a crew to recognize that an error has been made, the more difficult it is to recover once the correct course of action is recognized.

Unusual inflight and on-ground events require operators to respond quickly with limited or partial information while in a dynamic environment. The quality of these responses is dependant on the crew’s ability to detect, assess, and appropriately respond to signals present in the environment. The consequences of making incorrect decisions can be dire: miscommunication regarding heading, altitude, or location could result in controlled flight into terrain while misdiagnosis of a system malfunction could result in a delayed or incorrect response, causing damage to the aircraft or injury to personnel. It is important to recognize that selection of an improper course of action may not be the result of poor decision-making by the crew, but rather the result of the displays inaccurately communicating the current situation. Each accident, incident and unusual event provides the opportunity to evaluate the transfer of information between the aircraft and the crew and the strengths and weaknesses of these interactions. My challenge to you, as safety investigators, is to use these opportunities to gather data that can then be used to improve cockpit interfaces.

Appendix 1 presents a series of questions for use when exploring the effectiveness of communication between an aircraft and the crew. These questions are organized into four sections. The first section looks at the cues available to the crew, when they were available, and the quality of the signals presented. The second investigates what cues the crew needed to successfully resolve the event and whether the crew detected, interpreted and responded to these cues. The third is concerned with previous interactions between the crew and this and other display interfaces. The fourth presents concluding questions. This list is not intended to be all inclusive; it is offered as a guide to increase the understanding of communication between display interfaces and the crew. ♦

## References

1. Kanki, B.G. & Palmer, M.T. (1993) Communication and Crew Resource Management, in *Crew Resource Management*, Weiner, E.L., Kanki, B.G. & Helmreich, R.L. Eds, p. 99-136, Academic Press, San Diego, CA.
2. Besnard, D; Greathead, D. & Baxter; G. (2004) When mental models go wrong: Co-occurrences in dynamic, critical systems, *International Journal of Human-Computer Studies*, 60, 117-128.
3. Klein, G. (2003) *The Power of Intuition*, Currency Doubleday, New York, N.Y.
4. Endsley, M. (1999) Situational Awareness in Aviation Systems, in *Handbook of Aviation Human Factors*, Garland D.J., Wise J.A. & Hopkin, V.D. Eds., p. 257-276. Lawrence Erlbaum Associates, Mahwah, N.J.
5. Orasanu, J.M (1993) Decision-making in the cockpit, in *Crew Resource Management*, Weiner, E.L., Kanki, B.G. & Helmreich, R.L. Eds, p. 137-172, Academic Press, San Diego, CA.
6. Hutchins, E. (1995) *Cognition in the Wild*, the MIT Press, Cambridge, MA.
7. Hammer, J.M. (1999) Human Factors of Functionality and Intelligent

- Avionics, in *Handbook of Aviation Human Factors*, Garland D. J., Wise J. A. & Hopkin, V. D. Eds., p. 549-566, Lawrence Erlbaum Associates, Mahwah, N.J.
8. Sikorsky Aircraft (2005) *Rotorcraft Flight Manual, Sikorsky Model S-92A*.
9. Sanders, M.S. & McCormick, E.J. (1993) *Human Factors in Engineering and Design*, McGraw-Hill, New York.
10. Department of Defense (1999) *Military Standard 1472F: Department of Defense Design Criteria Standard: Human Engineering*.
11. Mack, A. & Rock, I. (1998) Inattentional Blindness: Perception without attention, in Wright, Richard D (Ed). *Visual attention*, p. 26-54, Oxford University Press, New York, N.Y, U.S.
12. Simmons, D.J., & Chabris, C.F. (1999) Gorillas in our midst: sustained inattention blindness for dynamic events, *Perception*, 28, 1059-1074.
13. DiVita, J., Obermayer, R., Nugent, W. & Linville, J.M. (2004) Verification of the change blindness phenomenon while managing critical events on a combat information display, *Human Factors*; 46:2, p. 205-218.
14. Rasmussen, J. (1993) Diagnostic Reasoning in Action, *IEEE Transactions on Systems, Man and Cybernetics*, 23(4), p. 981-992.
15. Sternberg, R.J. (1999) *Cognitive Psychology*, Second Edition, Harcourt Brace College Publishers, Orlando, FL.
16. Meyer, J. & Bitan, Y. (2002) Why better operators receive worse warnings, *Human Factors*, 44:3, p. 343-353.

## APPENDIX 1

### Part 1: Available Cues

What cues were available to the crew during the event?

- Describe the pertinent signals. These descriptions should include the icon/text used, whether the cue was visual/aural/other, location of the cue, whether the cue was attenuated, coupled with another cue, constant or intermittent and/or displayed in more than one location.

When did the cues appear (or extinguish) during the time line of events?

- Lay out signals along a chronological scale
- Include: whether the information updated during the course of events (if so how rapidly), whether the changes were attenuated, whether the location of the information was static or dynamic, and (if available) what rules drove the presentation of the data?

Were any distractors present during the event?

- Describe each distractor
- Was the distractor presented in visual, audio, tactile (vibration), scent form?
- Were threats such as smoke, fire, extreme weather conditions present?
- Were any social influences (provided by other crewmembers, agencies, or culture) in play?

Was a checklist available to manage this event?

Did the cues presented by the displays accurately reflect the status of the aircraft?

Did the cues presented by the displays support the correct decision/response path?

Were ambiguous indications displayed during this event?

### Part 2: Crew Response

What cues did the crew need to resolve (detect/diagnose/respond to) this event?

- Can include digital display or other system interfaces, aircraft, and environmental cues

Were these cues available (generated by aircraft or in environment)?

- If not why? (Can include parameter not monitored, system inoperative)

If available, was the cue detected?

- If not, why? (Can include cue was presented outside visual range, on MFD page not selected by crew, crew unaware infor-



mation was available, alert had been inadvertently silenced or extinguished or was otherwise masked)

If detected, was the cue correctly interpreted?

- If not, why? (Can include presentation did not allow for normal reaction times, meaning of icon/phraseology was not easily recognized, icon was infrequently observed, several signals were combined into a single alert)

Did the crew select the appropriate response?

- If not, why?

### **Part 3: Previous Interactions**

What previous experiences had the crew had with the displays?

(Include social interactions such as false alarms)

What experience level/familiarity with the interface did crews have?

Did crew have experience on more than one interface/aircraft?

- How current was crew with this interface?

Did cues used during simulator training match those used on the aircraft?

Did crews trust/distrust or accept/dismiss the information once it was detected?

Was scenario something they had encountered before be it in an aircraft, in a simulator, or anecdotally?

### **Part 4: Concluding Questions**

Were there any other obstacles to effective communication between the crews and the displays?

Did any elements of the display/interface contribute to effective communication?

# Cockpit Information Recorder for Helicopter Safety

By Roy G. Fox (M03514), Chief, Flight Safety, Bell Helicopter Textron Inc., Fort Worth, Tex., USA



*Roy Fox is chief of Flight Safety at Bell Helicopter with 42 years of experience in helicopter safety. He directs system safety engineering and other flight safety functions and directs the worldwide accident investigations of all civil and military Bell helicopters and tiltrotors. Fox is a helicopter accident reconstructionist. He headed up the helicopter industry committees of SAE, AIA, AHS, and HAI and lectures worldwide on accident investigation, crash survival, human performance, and other safety issues. He has provided technical papers in all aspects of aviation safety, including design, accident investigation, data analyses, human error, crash survival, and certification issues. He is a founding member of the International Helicopter Safety Team.*

## Abstract

Helicopter safety has stagnated with roughly the same number of civil accidents worldwide from year to year in spite of the annual introduction of new technology and new production helicopters. Helicopter accident investigations are stymied by infrequent on-site accident investigations and limited information. The few component failure investigations are done well, since there is hard evidence to examine that allows engineers to understand and duplicate/verify those failures. The remaining 80% or more of accident causes are human related or totally unknown. Many helicopter accident causes are based on circumstantial information rather than on documented facts. Accident causes such as “power loss for unknown reason” will repeat themselves year after year. There is little detailed information due to the lack of recorded data. Conventional digital flight data recorders (DFDR) are not required by regulations nor economically feasible for 95% of helicopters. Digital instruments/sensors needed for DFDR inputs do not exist on the vast majority of the civil helicopter fleet. Bell has designed a new low-cost, non-intrusive, generic approach of a cockpit information recorder (CIR) specifically for the existing Bell helicopter fleet. The CIR meets the needs of helicopter investigations and helicopter crash survivability criteria. A CIR consists of a high-resolution digital camera, GPS, self-contained sensor package, and a microphone. Data is stored in an external crash-survivable memory unit. The external memory unit has a field-removable memory card that can be inserted in a laptop PC for on-site accident investigation analysis and flight path recreation. Cockpit images at any point of the accident flight can be reviewed/analyzed to read instruments, pilot actions/inactions, and timing issues, and to document the flight and emergency procedures followed. CIR provides more information needed for helicopter accident investigations than DFDRs. Low cost is ensured by a generic set of components that can be applied to various models with minimal modification.

A prototype CIR was installed on the Polar First 407 that flew

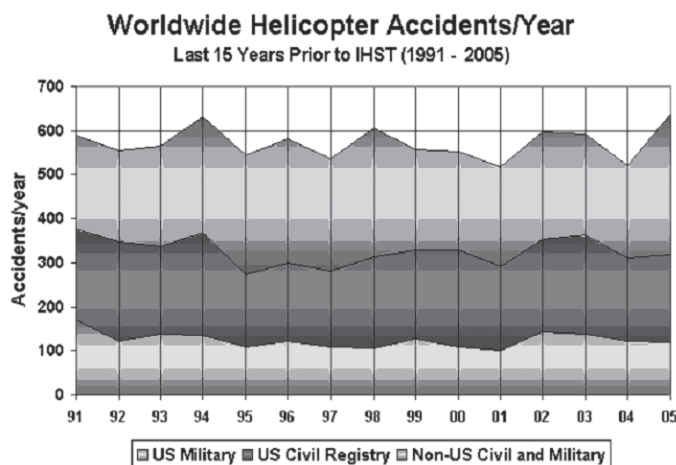

Figure 1. Worldwide helicopter accidents/year.

around the world via the South and North Poles in 2006/2007 (helicopter world record). The CIR flight data monitoring program will allow an operator to proactively use the CIR to identify trends, standardize operations, and assist in pilot training/standardization. This paper describes the development and planned CIR use for the more than 5,000 Bell 206/407 helicopters operating worldwide. The CIR does not replace any FDR/CVR required by regulation, but provides the information needed for accident investigation for the vast majority of helicopters not required to have an FDR. A CIR will reduce the time/cost of accident investigations, identify the actual causes, expedite corrective actions, and reduce subsequent accidents and injuries in helicopters.

## Background

Helicopter safety has improved very little in the last decade or so. This is true in the civil and military fleets of the United States and in other countries. The number of accidents each year for U.S.-registered helicopters, U.S. military services, and their foreign counterparts is shown in Figure 1. Worldwide, the helicopter industry averages about 1.5 accidents per day. Accident counts will increase as new aircraft are added to the fleet, but the number of aircraft also goes down from aircraft that are destroyed in accidents each year. Since the majority of the aircraft are in the fielded fleet, significant improvement in helicopter safety must address the existing aircraft in the fleets. In reality, the aircraft themselves are not responsible for 80% of the accidents. We must try something different and work on all causes. The number of accidents per year is a poor metric, as it does not include the effects of the number of flight hours of exposure. The worldwide military and civil helicopter flight hours are unknown. A program has been initiated to develop and track worldwide civil helicopter flight hours. This “data mining” computer program has

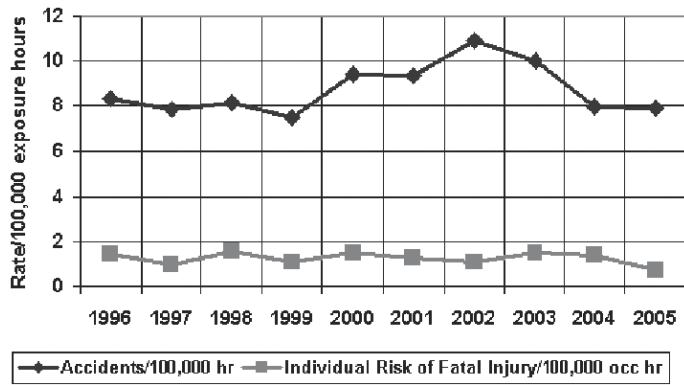

Figure 2. U.S.-registered helicopter accident rates prior to IHST.

been used by Bell to track the flight hours of its turbine fleet for years. As part of Bell's participation in the International Helicopter Safety Team (IHST) effort, all manufacturers' civil registered helicopters, piston and turbine powered, in all countries are being added to the data mining program and are being tracked.

The accidents/100,000 flight hour rate of U.S.-registered civil helicopter is an indicator of public awareness toward helicopter safety. The U.S.-registered civil helicopter accident rate over the 10-year period prior to the initiation of the IHST effort in January 2006 is shown in Figure 2 (Reference 1). The accident rate has not been improving. The individual occupant risk of fatal injury (RFI) is a product of accident rate (accidents/flight hour) times probability of fatal injury (number of fatalities/number of people on board all accidents who were exposed to harm). This RFI shown in Figure 2 indicated that the individual risk of fatal injury is not improving over the 10-year period. Again, some different approaches are needed to make significant improvements. There are some errors within the number of accidents, due to kit helicopter inclusion and some inaccuracies in the FAA survey flight hour estimate (Reference 2). However, this accident data on the HAI website is the primary public source of information, and thus is the public perception of helicopter safety. The achievement of the IHST goal will require accurate measurement of rate of change of different problems and their respective frequency. Thus, recording flight hours using the data mining effort will help to achieve this requirement.

**IHST**

The stagnation of helicopter safety has been limiting the expansion of the helicopter industry and where they are allowed to fly and land. The helicopter industry got together in October 2005 to discuss helicopter safety and what the industry could do. This International Helicopter Safety Symposium in Montreal, Canada included regulators, investigators, military services, original equipment manufacturers (OEM), helicopter industry organization, and operators from various countries (Reference 3). There was an agreement that the worldwide helicopter industry must do something toward significant helicopter safety improvements. This agreement formed the International Helicopter Safety Team (IHST) with the goal of reducing the helicopter accident rate by 80% in 10 years (2016). A previous study had indicated that an 80% helicopter accident rate reduction was possible (Reference 4). The 80% accident

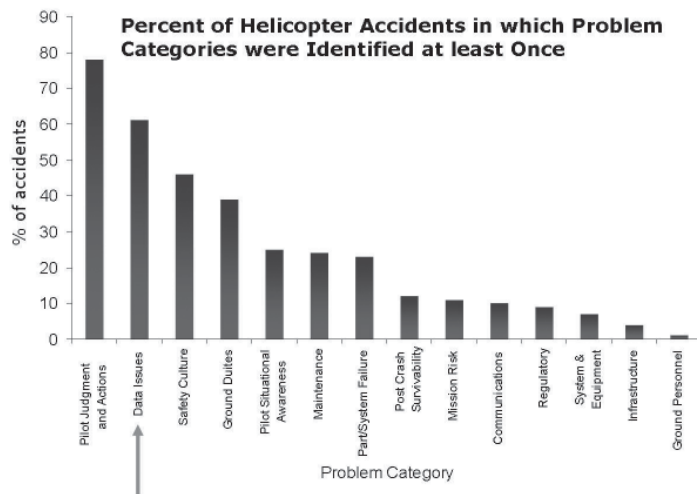

Figure 3. JHSAT CY 2000 percentage of safety problem categories.

rate reduction is a very ambitious goal but achievable if the proper interventions are used. Although the goal is for both civil and military helicopters worldwide, the military services of different countries may or may not participate. Many military services are secretive and do not release their accident data to the public. The IHST took the Commercial Aviation Safety Team (CAST) approach for large air carrier transport airplanes (Part 121 operations) and modified the process to be used in helicopters. CAST had the goal of an 80% fatal accident rate reduction in 10 years for commercial air carrier operations. IHST's goal is an 80% accident rate reduction for all civil helicopters

**Worldwide Fleet Distribution by Country**  
26,365 Aircraft Total

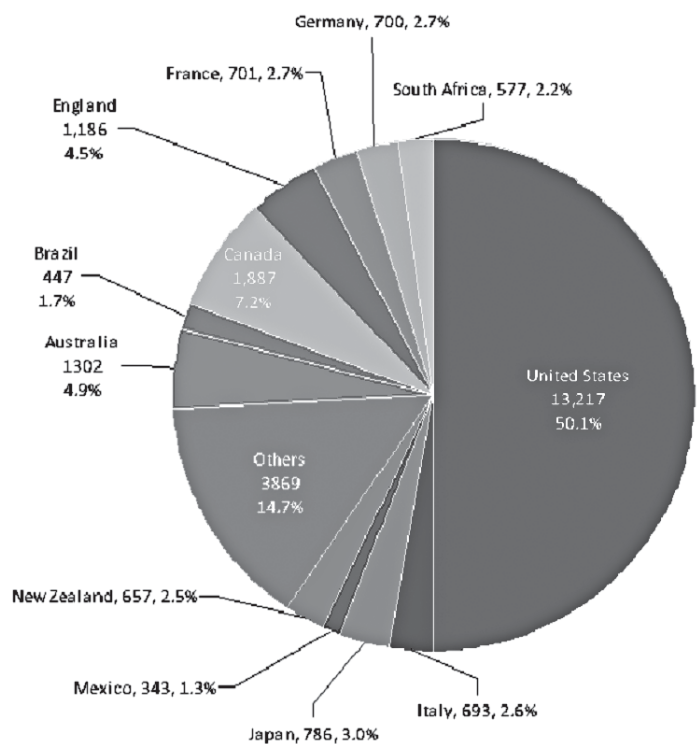

Figure 4. Worldwide civil helicopters.



## JHSAT Interim Recommendations

1. Promote Safety Management Systems (SMS)
2. Improve NTSB information
3. Develop accurate helicopter flight hours
4. Establish a helicopter safety website
5. Proximity detection equipment
6. Use flight recording devices and cockpit image recording systems
7. Improve pilot aeronautical decision-making

Table 1. 2006 Interim Recommendations List

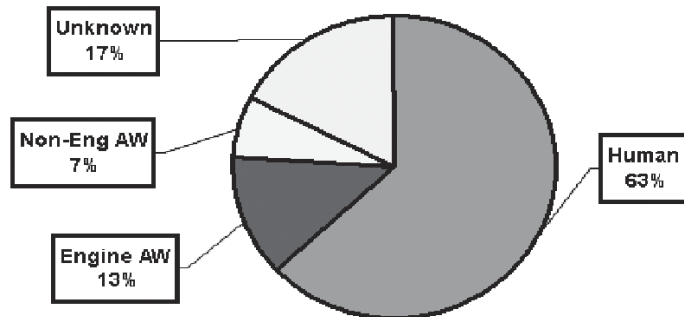

Figure 5. Worldwide helicopter accident causes.

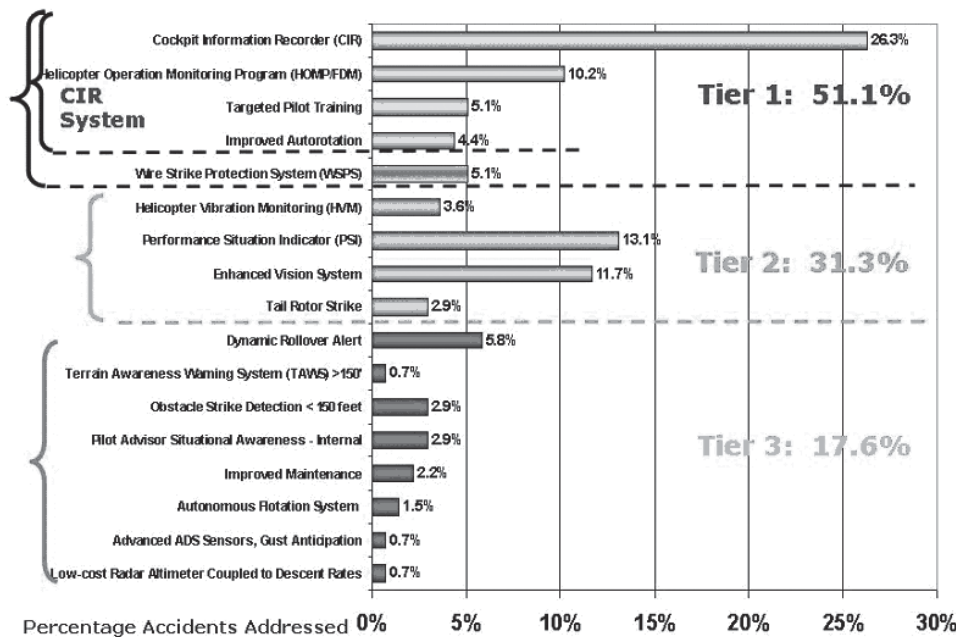

Figure 6. 206/407 safety initiative study.

(large and small, piston or turbine powered) and in all types of operation from private to offshore air taxi. It includes all accidents, not just those in which one of the occupants dies. It is critical that the IHST be data driven rather than opinion driven, which has been a major driver in helicopter safety for years. IHST formed two subgroups, the Joint Helicopter Safety Analysis Team (JHSAT) and the Joint Helicopter Safety Implementation Team (JHSIT). JHSAT analyzes accident data for root causes and potential interventions/mitigations and will measure the

effects of the various interventions. The U.S. JHSAT has finished its first report for the CY 2000 U. S.-registered helicopter accidents (Reference 5). The JHSAT is conducting a similar analysis for CY 2001 with more detailed analyses and comparison of changes from year to year. This annual JHSAT analysis process will continue to occur until the target year of CY 2016.

The IHST requested some interim recommendations based on previous studies so that the JHSAT implementation process could be developed and functional in time for the first JHSAT report. These recommendations were major areas of improvements needed, as seen by previous studies. This list of interim recommendations is Table 1 (Reference 6).

Note that the sixth recommendation states: "Use flight recording devices and cockpit image recording systems." The cockpit information recorder (CIR) discussed in this paper is intended to specifically address this recommendation. The bottom line in helicopter accident investigation is that we rarely know for sure what happened, other than mechanical failures, which are easily identified and documented. Many helicopter accident causes are deduced from circumstantial evidence or perhaps by comparison to an earlier accident that had a similar scenario. The helicopter industry needs the facts surrounding an accident, not opinions.

## JHSAT

The first JHSAT report of CY 2000 (Reference 5) broke accident cause factors into standard problem statements at the detail level and rolled up into larger problem categories. Figure 3 shows the

percentage of helicopter accidents in major problem categories. It was not surprising that "Pilot Judgment and Actions" was the most prominent factor and was present in 78% of the accidents. The percentage varies a little over the years but has always been the largest factor. It is also the most difficult one to mitigate. The second most frequent problem was "Data Issues," which was in 60% of the accidents. Some of this was due to the limitations of the investigation and that information was not available to understand what really happened in the cockpit and when. The CIR purpose is to document what actually happened in the cockpit, including instrument values, lights, noise, pilot actions, and inactions, when it happened, how the emergency was handled, and so on—basically, most of the information needed to accomplish the accident investigation other than parts examination and site information (wreckage diagram, debris paths, ground scars, etc.).

The JHSAT CY 2000 report (Reference 5) was focused on only U.S.-registered helicopters. However, Figure 4 from that report shows that the U.S.-registered helicopters account for 50% of the world civil registered helicopters. Although the causes of accidents will be similar worldwide, the regulatory/control environments may be different. Regardless, implementation is specifically a regional effort, not a single worldwide regulation. The IHST is international in scope so there are JHSATs and JHSITs

being set up in different countries/regions that will use their countries helicopter accident data for analysis using the common JHSAT analysis process. Sharing ideas and lessons learned from the different JHSATs is part of the IHST. Thus far, there are regional JHSATs in various stages of maturity in the United States, Canada, Europe, Brazil, India, and Australia. IHST information can be found on IHST website [www.ihst.org](http://www.ihst.org).

### Worldwide civil helicopter accident causes

There were 3,705 civil registered helicopter accidents worldwide for the period of January 1998 through December 2007 (the last 10 years). These accidents were analyzed to identify the basic causal areas, as shown in Figure 5. AW is an abbreviation for airworthiness failure, which some might call material failures, even though they might be electrical, hydraulic, etc. Basically, an airworthiness failure is a part functional failure that should not happen if the part still meets FAR requirements as originally certificated. For example, an improperly manufactured gear in a gearbox with proper oil, etc., fails internally; such is an airworthiness failure. If a gearbox seal fails during a flight, so that oil is lost, followed by failure of the gears—this is still an airworthiness failure. However, if the mechanic fails to put oil in the gearbox, which then fails, that is considered a maintenance error (one of the human errors) and is not an airworthiness failure. The largest portion of human causal factors involves pilots; this relative percentage has not changed significantly since the first 10 accidents in the beginning of aviation. Most human errors accidents are circumstantial with pieces of facts, because there is little to no documented proof. This dearth of knowledge precludes making significant improvements or the ability to know if particular changes (such as a procedure) are actually working in the fielded fleet operations. A low-cost means is needed to document and understand what was really happening in the cockpit. A generic concept of a cockpit information recorder (CIR) that gathers information in and around the cockpit without relying on the aircraft systems was described in Reference 7. That CIR uses a camera, microphone, and a GPS. The CIR has progressed from concept to a reality and has added features to increase operator use rather than just an accident investigation tool. This paper herein describes that journey to the present CIR, in which Bell plans to have a CIR Supplemental Type Certificate (STC) on Bell Model 407 by the end of 2008 and on Models 206s in 2009.

The CIR will provide the facts of what did or did not happen. A CIR may validate that a pilot used the proper procedures and crashed any way. As such, the OEM's procedure may need to be improved. Engine airworthiness is a separate airworthiness area as the engine OEM has the type certificate and is responsible for the engine design and continued airworthiness (Part 33). The remainder of the helicopter is noted as non-engine airworthiness (Part 27 or 29) for which the airframe OEM is responsible. Unknown are those accidents where little is known to be included in one of the other large cause factor "buckets." Having 17% of

## US Registered Helicopters over 1% of US Fleet (12,367 as of end of 2006)

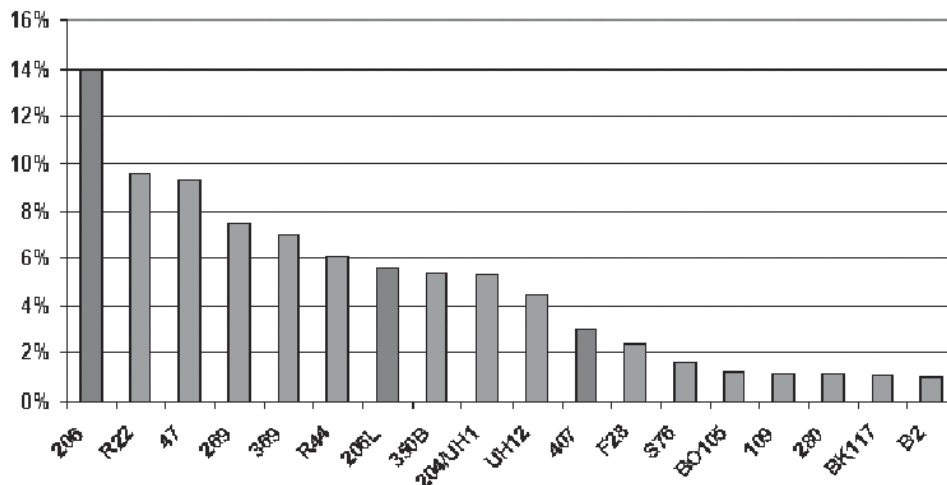
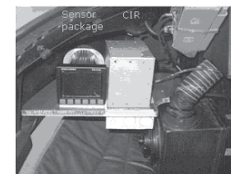
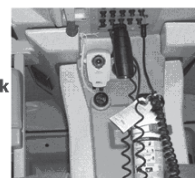

Figure 7. 206/407 CIR potential within U.S. fleet.

CIR Box & sensor package in left nose forward of instrument panel. FDM USB2 download port near pilot.



Cigarette pack size, digital surveillance camera and area mic. between pilots at back of overhead Circuit Breaker panel.



Crash/fire survivable External Memory Unit in box structure under Pilot seat. Most frequently recovered fuselage piece. Accessible at crash site.



Figure 8. CIR component locations.

the accident causes unknown means that those same types of accidents will continue to recur year to year. In many of the known factors, the actual root cause is unknown. For example, an accident reported cause of "power loss for unknown reasons" is tallied within engine airworthiness cause factor. However, nothing is correctable, as one cannot fix an "unknown" factor. These claimed "power loss for unknown reasons" accidents continue to occur year after year. We all do the best we can with what we have available. The CIR will eventually eliminate nearly all unknown factors except those where the aircraft/CIR was not recovered.

### Bell 80% reduction goal

Bell Helicopter has an active fleet of more than 15,000 helicopters in civil and military application. Only 38.3% of Bell accidents occur in the United States, whereas 61.7% of the accidents are in foreign countries. Bells account for 35.5% of the worldwide civil helicopter fleet, which is significantly more than the nearest competitor. If the IHST worldwide goal is to be met, Bell must at least meet an 80% reduction for its helicopters. Bell has an internal goal to reduce our accident rates by 80% by 2016. To determine what was needed, an analysis of Bell civil turbines accidents for 2004 to 2005 was conducted. This represented 5 million flight hours. As mentioned earlier, any hope of meeting an

80% reduction means a focused effort on fielded aircraft. Whatever is done in the field can be fairly quickly applied to a production aircraft. Further, 82% of Bell's civil turbine fleet are Models 206/407; thus initial safety focus is on those specific models. Since this fleet is extremely large (more than 5,000 aircraft), intervention cost per aircraft could be less when compared to a relatively small model fleet of, say, 200 aircraft. This large fleet can also provide the largest accident reduction in the shortest time. Further, by developing low-cost generic approaches for the 206/407 fleets, the same system could then be used on all other Bell models, for production and retrofit with compatibility checks and minor mounting and wire run changes.

### Bell 206/407 safety initiatives

The 2-year study was refined to include only the 206/407 series accidents and focused on the prime mitigation needed to eliminate those accidents. Generally there are several mitigations that could help a particular accident. The prime mitigation is the one with the best chance of mitigating that accident. Figure 6 shows the results of the 206/407 safety initiatives. The most significant mitigation is the cockpit information recorder (CIR) found in 26.3% of the accidents, because we don't really understand what happened in those accidents. The second mitigation, which accounted for 10.2% of the accidents was the Helicopter Operation Monitoring Program (HOMP), also called flight data monitoring (FDM), or FOQA in the airline world. FDM includes operator trending and use of their recorded data. CIR can provide a proactive means to reduce accidents as well as support an accident investigation. The next two mitigations "Targeted Pilot Training" and "Improved Autorotation" are part of the CIR system, as they allow us to target specific accident scenarios documented with the CIR and feed those scenarios into the pilot training, which includes autorotation training. Those four items will use the CIR information. The fifth line was "Wire Strike Protection System (WSPS)," which can handle the majority of the wire strike accidents. WSPS kits are available and installed on many helicopters today. WSPS are needed on all helicopters that operate where wires exist. Those five items are Bell's Tier 1 (highest priority), accounting for 51.1% of the 206/407 accidents.

Tiers 2 and 3 will be addressed later, after we get the CIRs in the field. Tier 2 includes Helicopter Vibration Monitoring for 3.6% of the causes. The Performance Situation Indicator (PSI) is an indicator of how close the pilot has placed the aircraft to the edge of aircraft performance and predictive of when the pilot may exceed the different performance envelopes if no corrective changes are made. In essence, it will tell you ahead of time as you approach the edge of the cliff, not warn you as you go over the cliff edge. PSI (13.1% of accidents) provides the pilot with an earlier indication to allow earlier corrective pilot actions, such as a go-around decision. Performance limits do not just consist of engine power limits and may change throughout the flight. Enhanced Vision Systems (EVS) are infrared systems that aid in seeing during low-visibility conditions such as night, brownouts, and whiteouts. Several vendors are developing EVS which could help in 11.7% of accidents where visibility loss is an issue. The last item in Tier 2 is tail rotor strikes, at 2.9% of accidents. Several companies are investigating proximity detection systems but none have yet developed systems with reasonable cost and weight. The tail rotor strike is a low-speed hover maneuvering issue rather than a far-distance high-speed detection issue. Tier 3 items will be addressed after Tier 2. The

distinction between Terrain Awareness Warning System (TAWS) for strikes above 150 feet and those obstacle strikes below 150 feet (46 m) was necessary, as TAWS is an aircraft-based GPS location being compared to the terrain elevation map database which is at the rocks, not the top of 120 foot (37 m) tall trees. An active onboard obstacle proximity detection system is needed for the takeoff, landing, and low-level maneuvering, when is the region below the 150 foot (46 m) above ground level.

### CIR potential influence on U.S. helicopter fleet

Figure 7 shows the models and their percentage of helicopters on the U.S. registry for those models with at least 1% of the U.S. fleet. Note that the 206 JetRangers, 206 LongRangers, and 407s account for 22.5% of the U.S. fleet. CIRs on these models can make a significant difference in accident rate reduction. It is anticipated that at least one other manufacturer is considering similar CIR means of recording data on non-digital helicopters (Reference 8).

### CIR is not regulatory

There is generally a lack of knowledge of what happened and when it happened for helicopter accident investigations other than those due to a broken part. A CIR is a low-cost approach to correct that lack of knowledge. In general, the documentation needed includes

- what the pilot can see, his actions/inactions, timing of actions, partial incapacitation signs, and potential interference by others.
- instruments values, cautions/warnings and other indicators.
- key helicopter parameters.
- ambient noises from the helicopter and crew.
- aircraft flight path (GPS) and attitude relative to terrain.
- internal cockpit environment changes (smoke, windscreen fogging, black glass displays, loose FOD, flying debris inside).

A flight data recorder (FDR) or digital flight data recorder (DFDR) could record some of this information, but both of these require sensors for input signals. The latest glass cockpit aircraft might have those DFDR inputs available, but the vast majority of helicopters do not. Thus the DFDR signals would require the addition of new sensors and recertification of all related certificated systems. DFDRs are far too expensive and heavy to be a realistic approach for the entire helicopter fleet. The specific requirement that mandates FDR/DFDR in the United States is the Code of Federal Regulations, specifically 14CFR135.152, which states

#### *Sec. 135.152 Flight recorders.*

*(a) No person may operate a multiengine, turbine powered airplane or rotorcraft having a passenger seating configuration, excluding any pilot seat, of 10 to 19 seats, that is brought onto the U.S. register after October 11, 1991, unless it is equipped with one or more approved flight recorders that utilize a digital method of recording and storing data, and a method of readily retrieving that data from the storage medium. The parameters specified in Appendix B or C, as applicable, of this part must be recorded within the range accuracy, resolution, and recording intervals as specified. The recorder shall retain no less than 8 hours of aircraft operation.*

*b) After October 11, 1991, no person may operate a multiengine, turbine-powered airplane having a passenger seating configuration of 20 to 30 seats or a multiengine, turbine-powered rotorcraft having a passenger seating configuration of 20 or more seats unless it is equipped with*



one or more approved flight recorders that utilize a digital method of recording and storing data, and a method of readily retrieving that data from the storage medium.

Unless the operator uses a multiturbine helicopter with 10 or more passenger seats for hire in the United States (e.g., operating under 14CFR135), that helicopter is not required to have an FDR. Only 5.9% of all helicopters on the U.S. registry as of the end of 2005 are multiturbine helicopters with 10 or more passenger seats. Thus the vast majority of helicopters is not equipped with a FDR. Further, not all multi-turbine helicopter operators operate under 14CFR135. If you do have an FDR, there are many channels of input parameters that must be recorded. If you don't have an electrical sensor for one of these parameters, you have to add a sensor and get that new installation certified. FDR systems certainly can help in an investigation if they are installed, but they do not cover all of the information needed in a helicopter accident investigation. For example, what is actually seen on a display by a pilot is not recorded in a FDR, only the electronic signals that went to the display.

The CIR is NOT a replacement for an FDR/DFDR or CVR where such is required by regulation. The CIR is for the rest of the fleet (95%) not having those regulatory requirements. The CIR could be added on such aircraft with a FDR, but the CIR is safety equipment beyond regulatory requirements and is not a MMEL item that would cause a flight delay, etc. In many cases, the CIR would allow the accident investigation to be nearly completed while on site and eliminate from further investigation those systems that are functioning properly. This may occur before an FDR has made it to the nearest FDR lab, which may be thousands of miles away. A fundamental driving factor is that the CIR will not be to any technical standard order (TSO) such as TSO-C124b or TSO-C176. Bell must have a low-cost CIR system that meet the needs of a helicopter investigation and encourages voluntary fitment by operators. Large airplane investigation needs that drove the TSO requirements are not applicable to the helicopter fleet, which needs a low-cost recorder. If a government mandate were made to force the CIR to meet TSO requirements, it would prevent the CIR from going forward into the fielded fleet for that particular country. Thus significant helicopter accidents reductions will not occur in that country but would in other countries. The key to the low-cost CIR is that it has low component cost (not high-dollar aviation certificated parts), low certification cost, and meets the helicopter industry needs including crash survivability. Certification tests are limited to those that are needed to ensure that the CIR does not degrade existing aircraft safety. If the CIR fails to function on a flight, the safety of the aircraft as certificated is still the same. CIR is a significant add-on safety feature that goes far beyond regulator requirements.

### CIR description

The CIR is an electronic data acquisition and storage system that obtains information needed for on-site helicopter accident investigations and provides capability for the operator to do trend monitoring for standardization of operations and other proactive safety activities. CIR is also an asset protection device. CIR is a generic system that can be added to different models with minimal modification (wiring and mounting). A CIR consists of

- high resolution color digital camera (day/night capability).



Figure 9. CIR camera image.



Figure 10. CIR image under low-light cockpit during NVG flight.

- area microphone for acoustical analysis of background noise.
- CIR box with process power and programs to control all CIR functions.
- global positioning system (GPS) antenna and card.
- ADAHRS sensor package for input.
- crash/fire survivable external memory unit.
- operator download USB 2.0 port and CIR status panel.
- ground station software installed on a laptop PC.
- an addition USB 2.0 connector for future expansion or operator use.

The CIR box and Air Data Attitude Heading Reference System (ADAHRS) sensor package are mounted in the nose of a 206/407, and the camera is similar to that in Figure 8. A sport aviation ADAHRS unit is used as a sensor package for the CIR. The display for this ADAHRS unit is covered and not to be used by the pilot. The ADAHRS has a connection into the pitot static lines to the airspeed indication system. The electrical interface with the aircraft is through a 28V DC circuit breaker off the battery bus. The CIR powers up when battery power is applied and

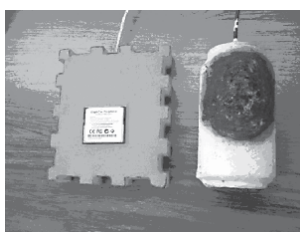

*Figure 11. CIR ground station software display on laptop (above). Figure 12. EMU and Prototype EMU (left).*

stops when the power is removed. There is no Remote Independent Power System (RIPS). Helicopter accidents where DC power is lost prior to impact are extremely rare to nonexistent; thus there is no needed for supplemental electrical power.

### Seeing what happened

The primary means to acquire information is a still digital color camera. The present surveillance digital camera provides 1,280 × 1,024 pixel color photos of the instrument panel, pilot's flight control sticks and pedals, and pilot actions. The camera has automatic light adjustment from extreme bright (which is common in polar regions) to the low-light environment in night vision goggles (NVG) equipped helicopters. The target image of Figure 9 is a single frame image from the prototype CIR installed on the Polar First 407 that flew around the world (over both poles), covering 32,206 nautical miles (59,645 kilometers) at its May 2007 completion. Images can be converted to a movie for general understanding of what is occurring. Single frame-to-frame examination is useful at specific points of interest. Although images are visible through the chin windows and windscreen, that information is secondary to the instruments and internal cockpit information. Some variance due to cameras may change this target view somewhat, but the basic area of interest is Figure 9.

Camera focus and automatic light adjustment is set on the instrument panel to ensure reading of instruments. This is especially critical when the outside is extremely bright. The camera can also handle low-light situations. An example out of a prototype CIR installed on Bell night vision goggles (NVG) training flight is seen in Figure 10. Reading instruments under NVG instrument lighting is possible, whereas the locations of the controls are not reliable. It is sometimes possible to enhance individual slides and determine control stick locations.

### CIR playback

The ground station software developed for the CIR operates on a laptop PC. Once the compact flash (CF) card is removed from the external memory unit (under IIC direction) and inserted into the laptop PC at the accident site, the software provides a screen like Figure 11. All data are indexed to the common GPS time. The lower right screen panel is the actual image taken. The recorded parameters from the sensor package and the instrument values derived by an optical recognition program (patent pending) are displayed in the simulation on the left side screen panel on a simulated instrument panel. The upper right screen panel is the typical strip chart display of multiple parameters (operator selected). All three screen panels are synchronized so the strip chart, instrument panel, and actual image are from the same GPS time. Figure 11 shows the cockpit view in the left panel, but the operator can also toggle to views from outside the aircraft over simulated terrain. The flight path is exportable as a GPX file. A standard GPX file of that flight can also be displayed on Google®Earth or other terrain software programs when the investigator has access to the Internet. It can also be view with any flight simulation software that accepts files with a .GPX extension, such as the Appareo Flight Evaluator software.

The external memory unit is not accessible to the operator and should only be opened in the event of an accident investigation under the authority of the investigator-in-charge (IIC). Flight data monitoring activities are day-to-day operations not related to an accident investigation and do not involve disassembly of the external memory unit. For the normal FDM use, the CIR stored data can be downloaded easily using a flash drive into a USB 2.0 port accessible to the operator after the flight. The normal FDM downloads would include all parameter data and GPS data, which will download quickly. If desired, the same USB port can be used to download the audio and image files, but the download time will be considerably longer due to the file size of the images.

### CIR recorded data

The following data are recorded and the latest are retained whereas older data are overwritten. All data are stored on a compact flash card inside the external memory unit.

- **Images.** The most current 1 hour of images taken and stored at three frames/sec. The next 3 hours are stored at one frame/sec. Thus there will be images for the last 4 hours of flight/operation.
- **Audio.** The area microphone will record ambient sounds for the last 4 hours.
- **GPS data.** The GPS data for the last 25 hours is recorded at 1 Hz.
- **Parameter data.** The parameter data for the last 25 hours is recorded at 3 Hz and in some cases higher.

Camera frame rate testing was done to find the minimum acceptable frame rate to minimize electronic storage needs. It was found that one frame per second was acceptable and would catch people quickly pointing or touching items on the instrument panel. Bell elected to go with three frames per second for the latest hour, and only retain one frame per second for the older images. Faster frame rates are possible, but lower resolution is needed to compensate for file size. Higher resolution images are a key driver for those few critical frames, and thus was the priority over frequency of images.



0.020" AL Sheet (External Intumescent paint)  
(Minutes vs Temp) 2150 F flame

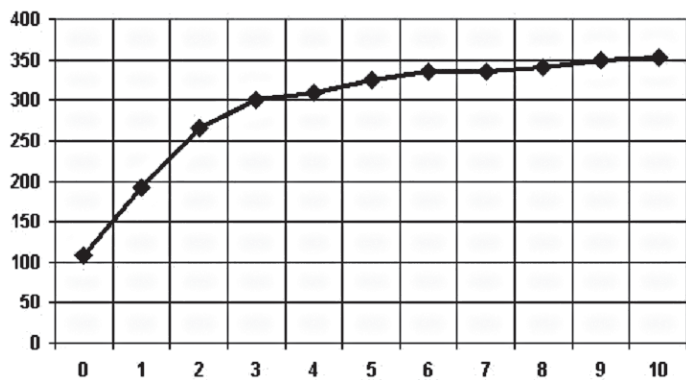

Figure 13. Intumescent paint fire test

**CIR external memory unit**

The external memory unit (EMU) is crash survivable to what a helicopter needs. Six prototype configurations of different means to handle fire and impact were tested. All six units were drop tested from a hangar and impacted concrete at 42 ft/sec (12.8 m/sec). This impact speed is the vertical impact velocity to which modern military helicopters are designed. The images stored in CF cards were then checked and were successively retrieved on a laptop. The six units were then tested with a 2,150°F (1,177°C) flame for different times up to 15 minutes. Fire testing was performed to evaluate different materials and approaches, not to find the longest time before loss of the memory data. Tests were terminated at different times depending on what we were investigating. One of the test units (on the right of Figure 12) is a soft drink can with a CF card, internal fire foam, and an external coat of intumescent paint. That soft drink can had been tested for 10 minutes when the test was terminated. The image memory was successfully retrieved from all 6 test units after the fire tests. The final CIR EMU is shown on the left of Figure 12 with a memory CF card placed on the EMU to show the relative size.

A fire test was conducted on a 0.020 inch aluminum sheet that had been painted with a coat of intumescent paint. The temperature (in degrees Fahrenheit [°F]) on the inside surface versus time is shown in Figure 13. The flame temperature was 2,150°F (1,177°C). The test was terminated due to propane tank exhaustion, with a temperature of 350°F (177°C). The final CIR EMU has not yet been fire tested, but will far exceed the soft drink can test that was stopped before reaching a limit. It is anticipated that at least 30 minutes can be achieved on the EMU.

**Flight data monitoring**

The CIR data recorder allows an operator to have a flight data monitoring (FDM) program. Downloaded data allow trend monitoring for parts, flight profiles, etc., and is critical information for operations standardization. Monitoring will allow the operator to correct any inappropriate flying or operational aspect before an accident occurs. FDM is part of a company Safety Management System (SMS) program. Bell will provide a web-based site for CIR owners to use and coordinate information with Bell.

**CIR potential use—Example 1**

Over the years, there were Model 206 accidents in which the pi-

206 Engine Power Loss Accidents  
(1977-2004 Real, Suspected, & Claimed: 49.788 million hours)

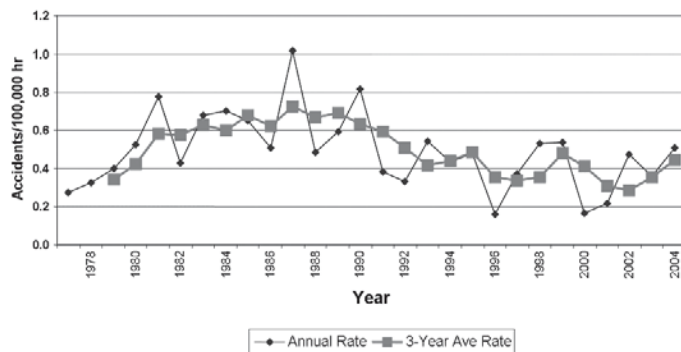

Figure 14. 206 real and claimed power loss accident rate.

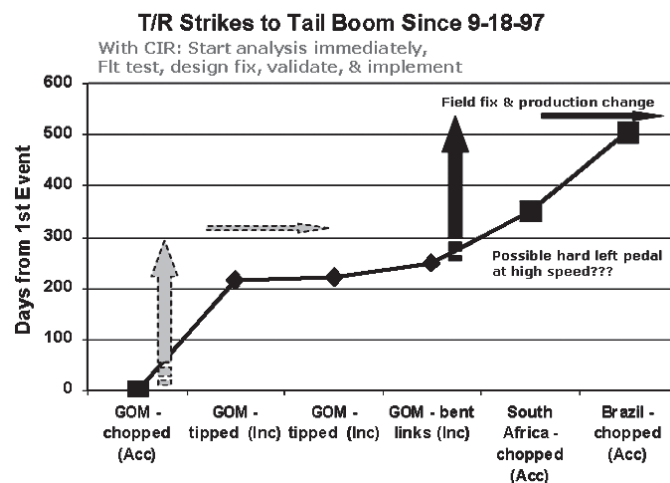

Figure 15. CIR potential to speed up accident investigation.

lot claimed he had a power loss. Subsequent engine test runs indicated the engine was fine during the test. These types of investigations typically result in a cause of “power loss for unknown reasons.” That does close out a report, but how does the engine manufacturer fix the “unknown reason”? The answer is it cannot. That type of accident continues to be reported from year to year. Figure 14 shows the claimed and actual power loss accidents of the 206. In 1990, a pilot in this type of accident actually told Bell that he had inadvertently activated the fuel shutoff valve by mistake but immediately turned it back on (too late!). With this knowledge, Bell put a guard over that switch and retrofitted the fleet in 1990. Note the accident rate reduction. We then asked the FAA to issue an AD and got a further drop in the accident rate due to power losses. Had CIR technology been in place years ago, Bell would have added that guard with the first proof of what the pilot was doing inadvertently. Knowledge is needed, and CIR can provide it.

**CIR potential use—Example 2**

Sometimes a brand-new type of accident cause occurs. The faster that causal factor is documented, the quicker the field fix occurs. The 407 has such a situation. The pilot reported a bang, and he landed successfully on popout floats in the ocean with no problem. People and aircraft (less the back end of the tail boom) were retrieved by boats. The aft end of the tail boom with the tail rotor



and vertical fin were noted as missing after the aircraft landed on the water. The missing tail boom and tail rotor were not recovered until many months later. Some time later, another accident happened in which a rapid left pedal occurred at high speed. Now with some potential evidence, testing of the unique situation was done, and potential improvements were developed. A fix to preclude the pilot from introducing full left pedal at high speed was quickly introduced to the field. Had a CIR been available and installed on the first accident aircraft, it would have recorded the sharp left pedal input at high speed. The accident investigation on the real cause could have started on Day 2, not months later after the sunken tail boom pieces were found. A CIR will quickly identify these unusual pilot action accidents so that correction can begin quickly.

### Summary

Bell is committed to the IHST goal of an 80% accident rate reduction by 2016 and will do its part. Bell's major thrust to get the largest improvement in the shortest time period is to develop and field a low-cost cockpit information recorder (CIR). A CIR will allow the understanding of human and unknown cause accidents needed for improvements in aircraft, procedures, and operations. A CIR will significantly speed up the process of accident

investigation and fielding of corrections. The time and expense of accident investigations will be reduced by a CIR. Low-cost CIRs also have FDM capability, which will encourage operators to install CIRs on a voluntary basis. The CIR is being designed to helicopter needs and is an added safety feature that does not degrade existing certification safety. Overall, the CIR is going to allow helicopter safety to go to a new safety plateau. ♦

### References

1. Helicopter Association International website, <http://www.rotor.com/> (July 3, 2008).
2. "General Aviation and Part 135 Activities Surveys," Federal Aviation Administration website, [http://www.faa.gov/data\\_statistics/aviation\\_data\\_statistics/general\\_aviation](http://www.faa.gov/data_statistics/aviation_data_statistics/general_aviation) (July 3, 2008).
3. International Helicopter Safety Symposium, Montreal, Canada 2005.
4. Fox, R.G., "Measuring Safety Investment Effectiveness Relative to Risks," American Helicopter Society 54<sup>th</sup> Forum, May 1998.
5. "U. S. Joint Helicopter Safety Analysis Team: Year 2000 Report," September 2007. May be accessed at the International Helicopter Safety Team website, <http://www.ihst.org/index.php> (July 3, 2008).
6. Liptak, Mark, et al, "Interim Safety Recommendations to the International Helicopter Safety Team," U.S. JHSAT, presented at Carmel IHST meeting, November 2006.
7. Fox, R.G., "The Path to the Next Helicopter Safety Plateau," American Helicopter Society 61st Forum, June 2005.
8. Barclay, A., "Cockpit Image Recording Systems," International Helicopter Safety Symposium, September 2007.

# Use of Model Helicopter and Precise Differential GPS on the Occurrence Site Survey

By Wen-Lin, Guan; Ming-Hao, Young; Tian-Fu, Yeh; and Hong T. Young;  
Aviation Safety Council (ASC), Taiwan, ROC, Tel: +886-2-89127388 Fax: +886-2-89127398



**Dr. Wen-Lin (Michael) Guan** is the director of the Investigation Laboratory with the Aviation Safety Council (ASC). He joined the ASC in 1998 and has been involved in more than 40 investigations.



**Ming-Hao Young** is a flight recorders engineer with the ASC. He holds a master's degree in remote sensing from the National Central University; he joined the ASC in 2001.



**Tian-Fu (William) Yeh** is a flight recorders engineer with the ASC. He holds a master's degree in aeronautics from the National Cheng Kung University; he joined the ASC in 2003.



**Dr. Hong-Tsu Young** is the managing director of the ASC. His career experiences include the program coordinator for the National Taiwan University Commercial Pilot Training Program and director of the machine workshop, Department of Mechanical Engineering, National Taiwan University.

## I. Introduction

### The evolution of site survey techniques at ASC

ASC is integrating several techniques to improve the position accuracy and efficiency of the site survey. In the beginning, the differential global positioning system (DGPS) and the handheld laser ranger were adopted in site survey equipment to locate wreckage, ground scars, and relevant ground features. For the post-processing, the geographical information system (GIS) was used to map all the spatial information, such as flight path, ground track, Jeppesen charts, radar images, etc. In the early stage, ASC found that DGPS and the laser ranger could assist in the occurrence investigation to reduce the working time of the site survey. Two catastrophic accidents were introduced to show its benefits.

A more detailed description of site survey techniques are explained in Section II.

Wreckage distributed over a wide area or in rugged terrain is very difficult to access. Gathering a bird's-eye view of wreckage distribution and high-resolution aerial photos or satellite images instantaneously are common challenges to aviation safety investigators. In 2004, ASC began to resolve these problems by self-integrating an RC (radio-controlled) model helicopter to take aerial photography. Integrating a precise DGPS and image-based analysis is cost effective in the application of 3-D modeling

### Developing an RC model helicopter at ASC

During the last decades, many unmanned air vehicles (UAV) had been developed to perform aerial photographic missions (see Reference 1, 2). The common characteristics of fixed-wing UAVs included long endurance, middle to high cruising altitudes, and different levels of autonomous flight (see Reference 3). In contrast to the commercial fixed-wing UAV, the self-integrating RC model helicopter is portable and easily assembled and deployed. ASC decided to use the RC model helicopter as a mobile platform to carry out the mission of aerial photography. Figure 1 shows the architecture—there are two subsystems to perform the requirement. The total cost of an RC model helicopter is about US\$8,000.

### (a) Aerial photography system

The aerial photographic system includes an RC model helicopter, control system, and photographic platform. The model helicopter is an HIROBO FRYER 90 with a payload capability up to 10 kg. On the ground, the pilot controls the model helicopter through a radio controller with 10 channels. The ground pilot's control commands are transmitted to the onboard receiver of the model helicopter and trigger servos to deflect the control surfaces.

In order to improve the quality of aerial photo and surveillance video, a passive absorbing device was designed onboard the photographic system of the RC model helicopter. The onboard payloads include a digital camera with 9 mega pixels, digital video, color CCD camera, GPS receiver, and real-time video transmitter. The angle of the entire onboard platform can be changed by a radio control channel. The color CCD camera superimposes the GPS position information (GPS time, latitude, longitude, height, heading, and ground speed), then the superimposed surveillance video is transmitted to a ground station by a 2.4 GHz video transmitter.

Based on the surveillance video on the ground station, an ASC investigator can coordinate with the ground pilot to decide when to trigger the digital camera. Usually, a lighter payload is

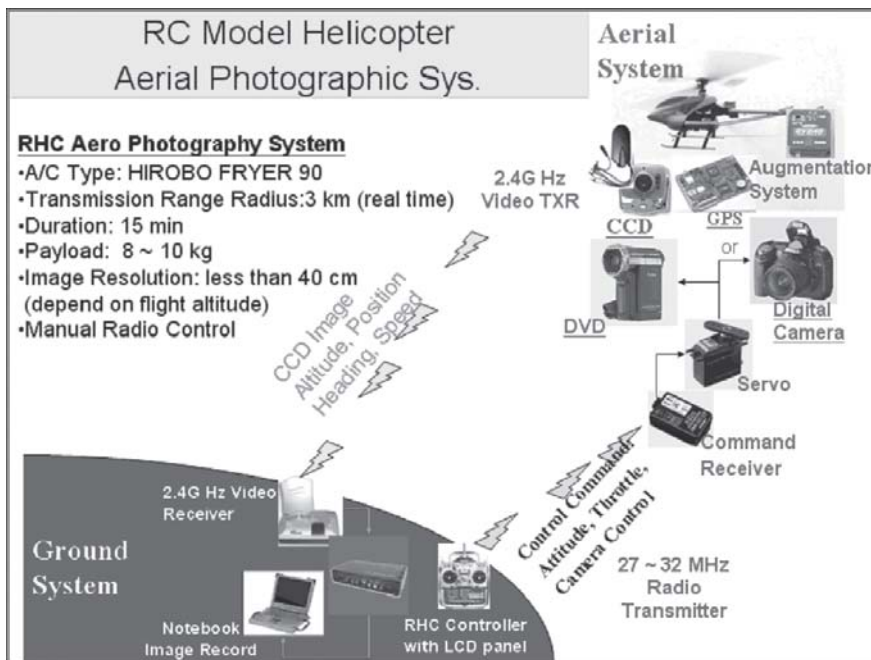

Figure 1. The system architecture of RC model helicopter at ASC.

preselected to perform quick surveys. According to the results of the initial survey, the high-resolution digital camera and video recorder can be installed on the platform to carry out the precise aerial survey mission.

**(b) Ground system**

The ground station includes a 2.4 GHz video receiver, remote controller with six channels, and a laptop computer. The ground station could in near real time display the superimposed video on the pilot's portable device and record the video on the laptop computer in near real time. The on-ground pilot of the RC model helicopter adjusts the operating altitude and direction and other control command through a portable device.

**Post-process of the aerial photos**

Each aerial photo taken by the RC model helicopter may be useful to show the occurrence site. If the wreckage is not widespread,

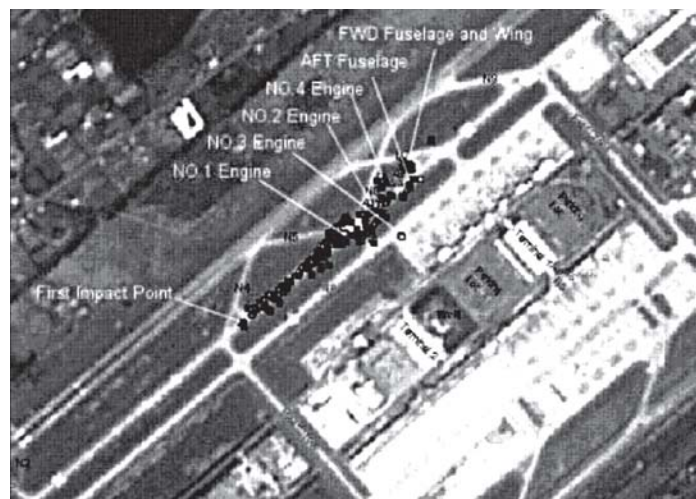

Figure 2. The superposition of SQ006 wreckage distribution and satellite image.

one aerial photo maybe enough to cover the entire occurrence site. If the wreckage is distributed more than hundreds or thousands of meters away, many aerial photos are needed to obtain the aerial panoramic view. To do follow-on measurements on the aerial photos, rectification of the photos should be done first.

There are two methods to rectify the aerial photos. A more detailed description is explained in Section III. The imprecise method is to ignore the distortion of the camera lens, choosing at least three GCPs from the aerial photo then rectify it by software directly. The precise method is to calibrate the camera first, put the lens distortion parameters into a commercial software program, and perform aerial triangulation to discover the orientation parameters of the photo. Finally, an orthogonal-image is generated and superimposed with the digital terrain model (DTM). These corrected images could be used in a large mosaic or superposed on other aerial photos/satellite images and terrain data to reconstruct the 3-D environment of the occurrence site.

**II. Review of two fatal accidents**

**B-747-400 Crash at Hong Kong International Airport (Oct. 31, 2000)**

Investigator-in-charge: Aviation Safety Council (ASC)

Invited accredited representatives: the NTSB (the state manufacturer), MCIT1 (the state of Operator), and Taiwan CAA

**History of flight**

On Oct. 31, 2000, at 2317 Taipei local time, Singapore Airlines (SIA) Flight SQ006 (B747-400, Reg. No. 9V-SPK), crashed on a partially closed runway at Chiang Kai-Shek (CKS) International Airport during takeoff. Heavy rain and strong winds from typhoon Xangsane prevailed at the time of the accident. SQ006 was on a scheduled passenger flight from CKS Airport, Taiwan, ROC, to Los Angeles International Airport, Los Angeles, Calif., USA. The flight departed with three flightcrew members, 17 cabin crewmembers, and 159 passengers on board.

The aircraft was destroyed by its collision with construction equipment and runway construction pits on Runway 05R and by post-impact fire. There were 83 fatalities, including 4 cabin crewmembers and 79 passengers; 39 seriously injured, including 4 cabin crewmembers and 35 passengers; and 32 minor injuries, including 1 flightcrew member, 9 cabin crewmembers, and 22 passengers.

**The site survey task**

Two survey teams joined together to perform the ground survey and aerial survey. The ground survey teams equipped with two sets of DGPS receivers, a digital camera, and relevant field notes. Due to the shortage of technical manpower, ASC hired four technical engineers with GPS experience to join the site survey, and ASC appointed one investigator to lead the ground survey team and prepare the relevant plan. They spent 3.5 days finishing the well-planned site survey task. The survey included aircraft wreckage and ground marks conducted from Taxiway N1 through N8 along Runway 05R. The landing gear tire mark from the begin-



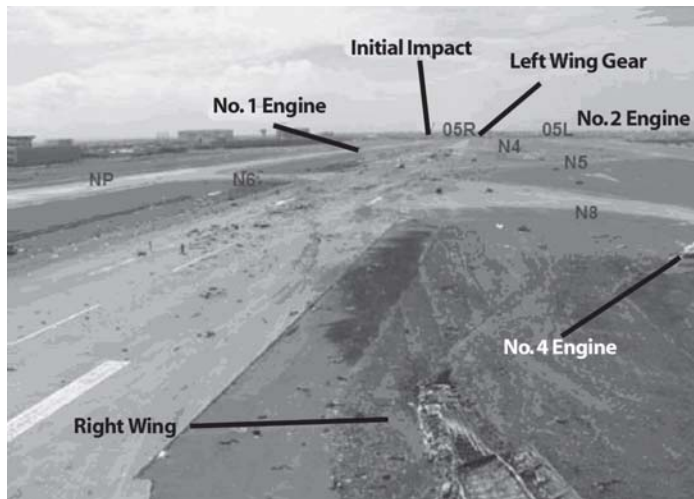

Figure 3. Partial wreckage distribution of SQ006 (as seen opposite from the flight direction).

ning of Taxiway N1 to the initial impact point was also documented. The tire marks were visible in the damp, early morning but not visible in drier afternoon or when the runway was wet.

After the accident happened, typhoon Xangsane had invaded the north of Taiwan more than 36 hours. Therefore, the aerial survey mission was postponed about 1.5 days. From November 2-3, the Aerial Survey Office of the Forestry Bureau used a Beechcraft BE-350 to perform the aerial survey. The survey field included Runway 05L and 05R and Taxiways (N1 ~ N9). Figure 2 shows the superposition of SQ006 wreckage distribution and a satellite image; Figure 3 shows the SQ006 partial wreckage distribution.

The operational cost of the ground survey and aerial survey were about 56,000 NTD (about US\$1,800) and 500,000 NTD (about US\$16,000), respectively.

#### **MD-11 crash at Hong Kong International Airport (Aug. 22, 1999)**

Investigator-in-charge: CAD, Hong Kong

Invited accredited representatives: the NTSB (the state of manufacture), ASC (the state of operator)

#### **History of flight**

On Aug. 22, 1999, China Airline's Flight CI642 (MD-11, Reg. No. B-150) was scheduled to operate from Bangkok to Taipei with an intermediate stop at Hong Kong International Airport (HKIA). The flight departed from Bangkok on schedule with 300 passengers and 15 crewmembers on board. About 1947 Taipei local time, HKIA was affected by weather associated with a tropical cyclone centered approximately 50 kilometers to the northeast. At the airport, there was a strong gusting wind from the northwest with heavy rain, resulting in a wet runway.

Flight CI642 carried out an ILS approach to Runway 25L. After becoming visual with the runway at approximately 700 feet, the pilot flying then disconnected the autopilot but left the autothrottle system engaged. Flight CI642 continued to track the extended runway centerline, but descended and stabilized slightly low on the glideslope until the normal flare height was reached. Although an attempt was made to flare the aircraft, this did not arrest the rate of descent and resulted in an extremely hard impact with the runway in a slightly right wing-down attitude. This was followed by

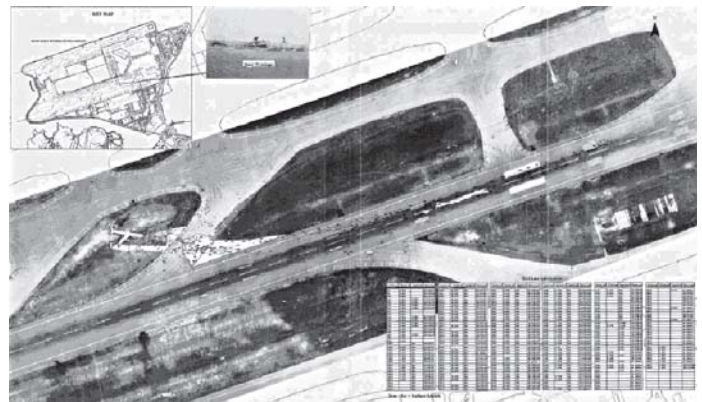

Figure 4. CI642 superposition of wreckage distribution and aerial photo.



Figure 5. The perspective view of CI642 main wreckage.

collapse of the right main landing gear, separation of the right wing, an outbreak of fire and an uncontrollable roll and yaw to the right. Flight CI642 ended up in an inverted, reversed position on a grassy area just to the right of the runway.

Due to the accident, two passengers were found dead on arrival, and six crewmembers and 45 passengers were seriously injured. One of the seriously injured passengers died 5 days later in the hospital.

#### **The site survey task**

After the accident, CAD was outsourcing the task of ground survey and aerial survey to the Survey and Mapping Office of Land Department. About 20 technical staffers spent one week to finish the survey task. The wreckage survey field included the recording of the final position of the main wreckage, the wreckage parts, and the skid marks obvious on Runway 25L and adjacent landscape areas. Figure 4 displays the superposition of the CI642 wreckage distribution and aerial photo; Figure 5 displays the perspective view of the main wreckage of CI642.

#### **Challenge and lessons learned**

- Prepared an outsourcing plan before an aviation disaster happens. The plan should include the requiring positioning accuracy, mobilization time of technical persons, detail items of billing, contact windows, report content of the site survey, and geospatial data layers and formats.
- Under severe weather conditions, investigators should be equipped with waterproof GPS, camera, and video recorder, etc.
- The mission of aerial surveillance is time consuming and ex-

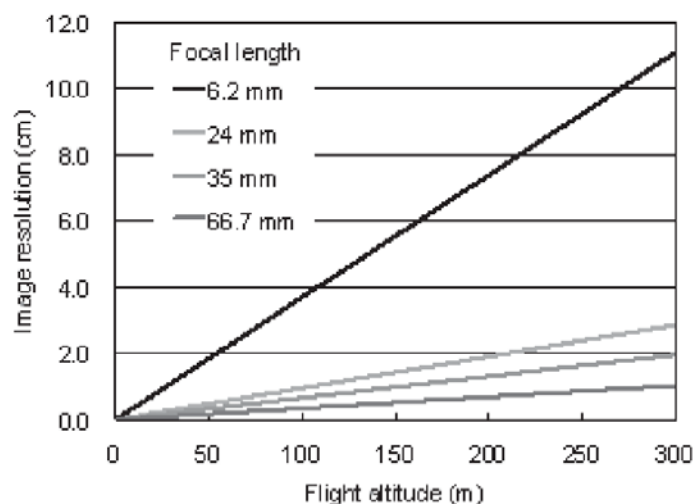

Figure 6. The relationship of relative image resolution and flight altitude.

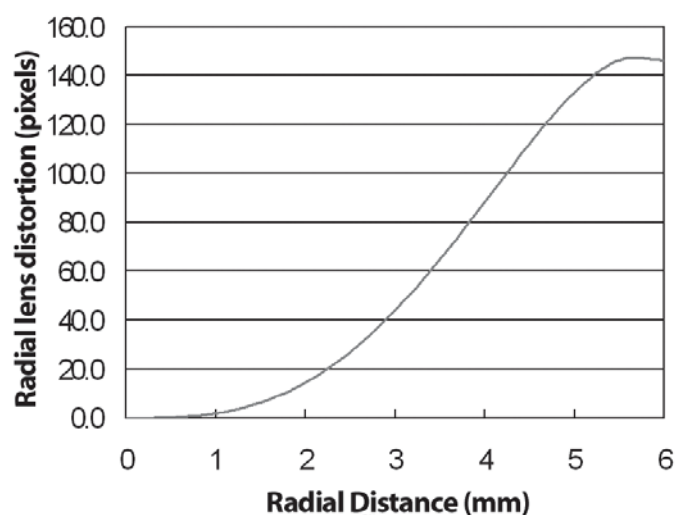

Figure 8. Radial lens distortion.

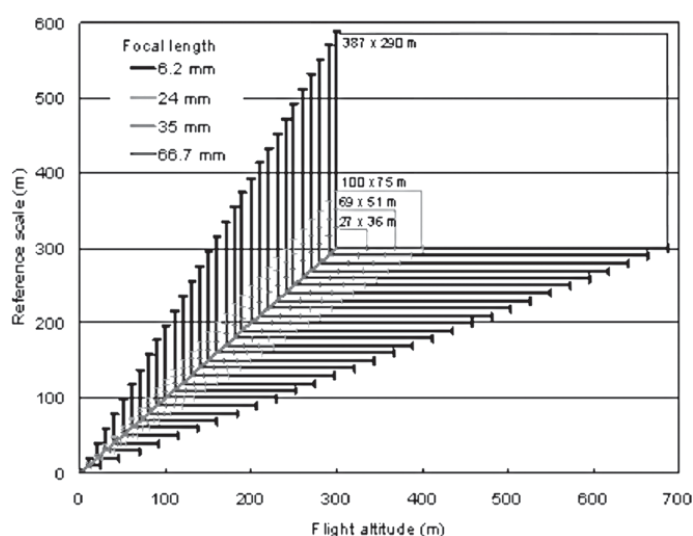

Figure 7. The relationship of relative ground coverage and flight altitude.

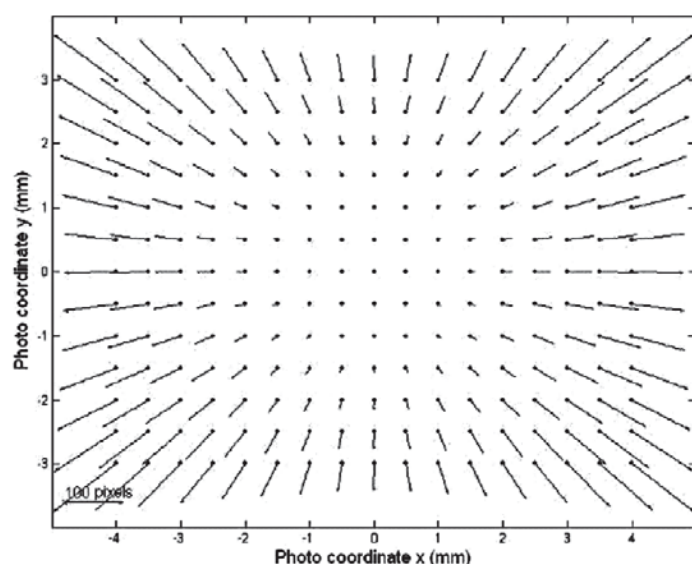

Figure 9. Total lens distortion.

pensive. Aviation safety investigators may consider alternative methods to achieve the essential requirements—timely cost-effective, and high-resolution aerial photos to record the wreckage distribution.

### III. The results and discussion

The RC model helicopter aerial photographic system had not been used in an accident investigation at ASC for the past 4 years. However, ASC staffers exercised the system to evaluate the procedures and performance. This section describes the characteristics of the onboard digital camera, the rectify methods of aerial photos, and two exercises at suburban and mountainous areas.

#### Characteristics of onboard digital camera

The onboard digital camera is a Fujifilm FinePix S9500, with 9.0 million effective pixels, and 1/1.6 inch super CCD (6 mm x 8 mm). Its focal length ranges from 6.2 mm to 66.7 mm with a maximum resolution 9.125 mega pixels (i.e., 2616 x 3488).

Four kinds of different focal lengths (6.2 mm, 24 mm, 35 mm,

and 66.7 mm) estimate relative image resolution and ground coverage at different flight altitudes. The results are shown in Figure 6 and Figure 7. To show that resolution varies with flight altitudes, two examples are illustrated here. (1) Using the wide-angle camera with a focal length of 6.2 mm and a flight altitude of 300 m AGL. The relative ground coverage is 387 m x 290 m. (2) Using a tele-angle side at the same altitude, the relative ground coverage is only 27 m x 36 m.

To avoid misunderstanding during post-process, before measuring the relative distance from those aerial photos, the distortions should be considered first. Table 1 shows that most of the distortion came from radial direction of the lens. According to Figure 8 and Figure 9, the farther away from the image's center, the more distortion there will be. The maximum distortion of the lens is 137.3 pixels.

Table 1. The Maximum Lens Distortion.

	Axis-x ( Pixels )	Axis-y ( Pixels )
Radial lens distortion	-109.1	-83.4
Decentering lens distortion	-2.61	-3.52
Total lens distortion		137.3



**Image rectifying method**

The following section explains how to rectify aerial photos. Two rectification methods mentioned in Section I will be explained in detail here. The precise method considers the distortion of the lens, and the influence of terrain, while the other does not.

**Imprecise method**

GCPs are the only known points to register the aerial photos to base maps in the imprecise method. GCPs are preselected points that are recognized from both aerial photos and base maps. The sources of the base map include Jeppesen charts, satellite images, and electronic maps. Therefore, the GCP's image coordinates and geographic coordinates were both known before the survey or determined by DGPS.

In general, satellite images are used as the base maps of area of interest (AOI); sometimes 1/5000 electronic maps are another choice. Satellite images can be gotten from Google Earth. Global Mapper is commercial software with the functions listed below: (1) picking out at least three GCPs, (2) rectifying the aerial photo through the default setting in the software (see Reference 4) Since the method did not consider the lens distortion and the terrain effect, the error of the outer image and the area with folding terrain will be larger.

**Precise method**

This method considers the orientation and altitude of the onboard camera, the lens distortion, and the terrain effect. The detailed procedures are shown below. First, ASC staff uses the PhotoModeler software to calculate the parameters of lens distortion; the calibration grid is shown in Figure 10. Second, input relevant calibration parameters into Leica Photogrammetry Suite (LPS) software to go with the GCPs. Those GCPs are measured by precise DGPS to perform aerial triangulation and to get the accurate position and attitude of the onboard camera. Third, ortho-rectify the aerial photos using the digital terrain model (DTM) (see Reference 5). This method takes into consideration many error sources, so the accuracy is much better than that of the imprecise method.

**Results of flight tests**

**Performance flight test at mountainous area**

In November 2005, the mountainous area we chose was located at Yang Ming Shan National Park in Taipei. The RC model helicopter took off at an altitude of about 815 m. Figure 11 shows the elevation mark and ground preparation. This exercise dem-



Figure 10. Calibration grid.



Figure 11 (a) Altitude of takeoff site. (b) Preparing for takeoff.

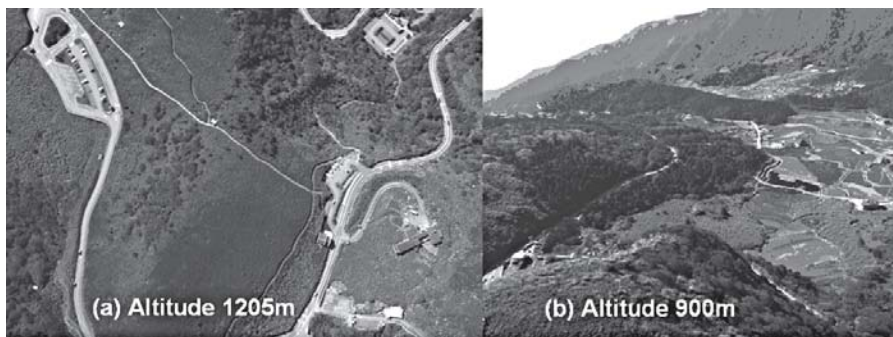

Figure 12. Aerial photo taken by digital camera at (a) altitude at 1,205 m (camera is nearly orthogonal). (b) Altitude at 900 m (camera is nearly seeing forward).

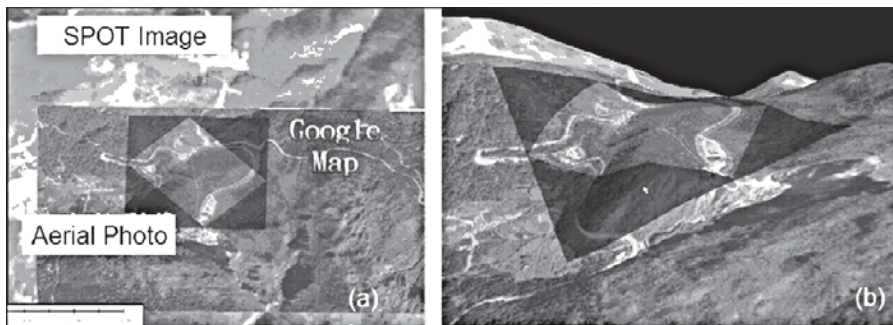

Figure 13. The images taken by DV (a) takeoff site. (b) Fumaroles near takeoff site.

onstrated that the model helicopter can maneuver at high altitude and used the imprecise method to superimpose the aerial photos. The onboard platform included a digital camera, GPS receiver board, CCD camera, and digital video recorder. The results showed the maximum flight altitude was about 1,215 m (almost 390 m above the ground station), and several aerial photos were taken as shown in Figure 12. Figure 13 shows some digital video clips from the onboard video recorder.

Figure 14 shows the results by superimposing the aerial photos—five GCPs were applied to correct the image distortion. The base maps of Figure 14 included a SPOT-5 satellite image with ground resolution of 6.25 m and extracted an image from Google Earth with ground resolution about 2 m. Figure 14 reveals that the edge of the superimposed photos could not correct the optical distortion. The relative position error is about 3 m.

**Integration flight test at suburban river valley**

In November 2006, another exercise was performed at a river valley of Wu-Lai, which is located at the southern outbound of Taipei city.





Figure 14. The superimposition of aerial photo and satellite images (SPOT-5, QuickBird).

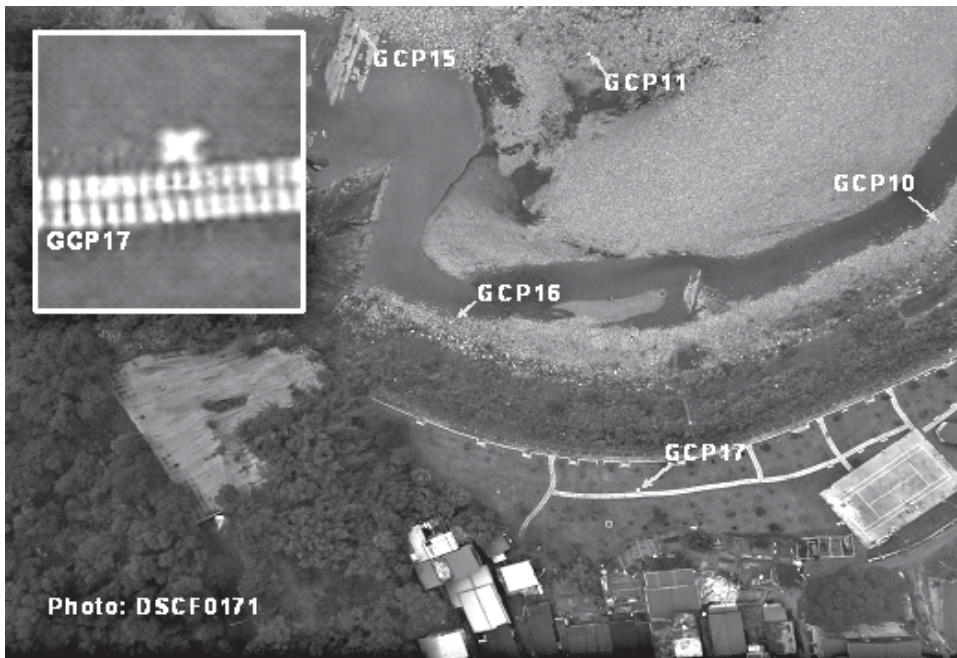
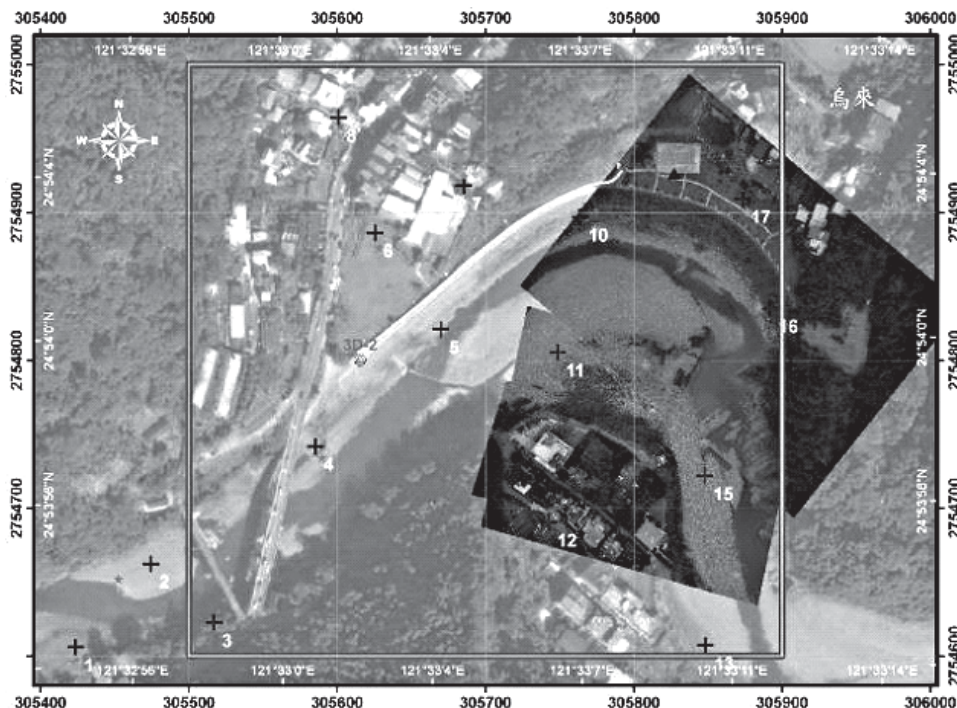

Figure 15 (a) Aerial photo (above). (b) Superimposition of aerial photos with a satellite image (below).



In average, the exercise area was about 400 m x 400 m. The model helicopter took off at an elevation of 180 m, and the relative covered area of the onboard digital camera was 240 m x 180 m. The cruising altitude of the model helicopter was about 186 m AGL.

Applying the precise method was used to superimpose the aerial photos. Two adjacent photos are overlapped more than 50% to correct image distortion. Each aerial photo contained at least four GCPs, which are distributed at the corner of the photos. The portable GCP was made of yellow plastic over cross tags a size of 1 m x 1 m, which was attached on the ground. The positions of the GCPs are measured by precise DGPS to ensure its accuracies within centimeters. Figure 15(a) shows the results of aerial photos taken by FinePix S9500. Figure 15(b) shows the results by superimposing the aerial photos and the satellite image extracted from Google Earth with a ground resolution of 1.5 m.

Based on the rectified aerial photos, the relative ground resolution varied from 7 cm to 30 cm—satellite image and precise DTM data with grid size 40 m x 40 m. ASC succeeded in generating the 3-D modeling of the river valley. The result is shown in Figure 16.

#### IV. Conclusion—remarks and future activities

Well-prepared site survey techniques are essential to aviation safety investigations. Survey techniques require positioning accuracy, mobility, scope and resources of the site survey, geospatial data layers and formats, and so on. ASC has successfully self-integrated an RC model helicopter aerial photographic system with a 10-kg payload capability. The proposed system also was calibrated with well defined procedures to rectify the aerial photos into a single ortho-photo with geographic coordinates.

To compare with other commercial UAV systems, or to outsource the national aerial surveillance agency to survey the occurrence site, the RC model helicopter is lightweight, highly mobile, and cost-effective and can obtain high-resolution panoramic photos. Whenever a fatal accident occurs and no instant aerial photos are available, the

application of the proposed system can save time, money, and work load in measuring the wreckage distribution, even assist in the rescue and reconstruction.

For future development of an RC model helicopter aerial photography system in assisting the site survey there are three major concerns, (1) waterproofing the onboard platform during periods of heavy rain and wind is needed; (2) if the focal length of the digital camera is too short, it will cause optical distortion especially at the outskirts of an interesting scene. The optical distortion may be improved by using a telescopic lens; (3) Rectifying the entire aerial photos is time-consuming and boring—developing a semi-automatic procedure is the trend. ♦

### References

1. Tad, McGeer, and Juris, Vagners, "Historic Crossing an Unmanned Aircraft's Atlantic Flight," *GPS World*, p. 24 ~ 30, February 1999.
2. AUVSI International Aerial Robotics Competition, <http://avdil.gtri.gatech.edu/AUVS/IARCLaunchPoint.html>.
3. Jessica Dooley, Ekaterina Taralova, Prasad Gabbur, Timothy Spriggs, "Development of an Autonomous Aerial Reconnaissance System," University of Arizona, Tucson, Az. <http://controls.ae.gatech.edu/gtar/>

- iarcpapers/uarizona2003.pdf
4. "Global mapper user manual," <http://www.globalmapper.com/helpv9/GlobalMapperHelp.pdf>.
  5. "Leica Photogrammetry Suite Project Manager," [http://rocky.ess.washington.edu/data/erdas\\_pdfs/LPS\\_PM.pdf](http://rocky.ess.washington.edu/data/erdas_pdfs/LPS_PM.pdf).

### Endnote

- <sup>1</sup> Ministry of Communications and Information Technology of Singapore

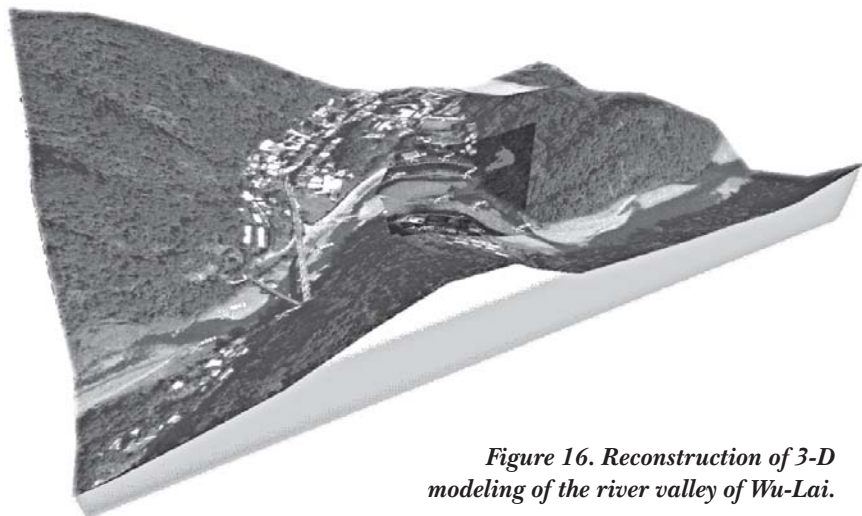

*Figure 16. Reconstruction of 3-D modeling of the river valley of Wu-Lai.*



# Gas Turbines and Ice—The Mysterious Culprit

By Al Weaver (MO4465), Pratt & Whitney



*Al Weaver is a Senior Fellow Emeritus having retired from Pratt & Whitney after a long career in promoting flight safety initiatives and expertise in accident investigation. He currently teaches the Gas Turbine Accident Investigation Course for the Southern California Safety Institute.*

This paper brings into focus the various kinds of ice that can affect gas turbine engines, leading to abnormalities and failures. It describes the sources of ice, its symptoms, and the investigative techniques and experience needed to identify probable sources. The author's objective is not to offer a complete and definitive overview on the subject of ice and gas turbine engines but to increase the general awareness of both aircraft operators and accident investigators on this problem. It is the author's opinion that in the future, there will still be major investigations involving this mysterious cause.

The operating environment of a jet aircraft may cause the engine to encounter icing conditions or to face the ingestion of ice from external sources. Post-event investigations have revealed numerous sources of ice that have led to significant damage to the engine(s) and/or to symptoms of abnormal operation, requiring pilot action. Of course, ice and gas turbines have been a recognized concern for many years, and current regulations in aircraft and turbine engine design address much of this concern. However, in spite of our general knowledge and assumptions, the operation of the aircraft in flight itself may present environmental conditions not anticipated or adequately controlled. Like other environmental factors, inflight icing is a threat that must be counteracted balancing the capability of the product to withstand extreme conditions and the need to restrict the acceptable operating environment.

## Sources of ice

The sources of ice that may threaten an aircraft jet engine can be fundamentally classified as follows.

**Ingested ice:** This definition refers to ice that has been generated outside the engine, either in the air by accretion to aircraft surfaces or from ground sources. During the event sequence, this ice finds its way into the engine.

## Examples of ingested ice

- Slab ice from runway edges or tops of snow banks displaced during reverse operation.
- Taxiway slush ridges on the gear released during gear retraction shortly after rotation.
- Ice left on the top of the fuselage or wings during dispatch and released at rotation during takeoff.

- Ice pooling overnight at the bottom of the engine inlet, released at high power during takeoff.
- Ice formed by leakages from the fuselage (e.g., lavatory potable water).
- Ice accretion on aircraft frontal surfaces (e.g., radomes and engine inlets) released during flight.
- Inflight hail.

**Internally generated ice:** This means ice that generates by the combination of ingested water (including snow/freezing fog, ice crystals, etc.) and engine working cycle conditions at certain power and rotation speed settings.

## Examples of internally generated ice

- Probe accretion that either blocks the probe or sheds abnormally causing engine damage.
- Ice accretion on rotating engine spinners shedding and causing damage.
- Ice accretion on fan blades either generating abnormal symptoms of vibration or shedding and causing damage.
- Ice accretion on stator vanes shedding and causing downstream ingestion damage.

## Symptoms of ice ingestion

Ice from either source may cause mechanical impact damage to either the engine stationary or rotating parts as well as blockages of air passages or probes affecting the engine stability and response to pilot commands. In some cases, investigators determined that ice ingestion had been so severe that the resulting FOD damage to the engine was beyond its certified blade loss capability in terms of quantity of blades released. The risk related to such inflight ice encounters is exacerbated by the fact that all engines on an aircraft operate at the same time under the same environmental conditions. Obviously a combination of malfunctions on multiple engines will significantly affect the pilot workload in addressing any of these abnormal conditions.

The following table lists possible consequences of ice-related events, possibly affecting more than one engine at the same time.

## Examples of abnormalities

- Mechanical damage dents/cusps/twist/bends/fractures to both stationary parts as well as rotating parts.
- Vibration either secondary to mechanical damage or simply due to uneven shedding of ice on a rotor.
- Engine inability to recover from stall/surging either from mechanical damage or ice-blocked bleed systems.
- Engine control system effects from ice-blocked probes.

It should be noted that engines can be affected by ice (and in particular by ice particles at altitude) even if no airframe icing is



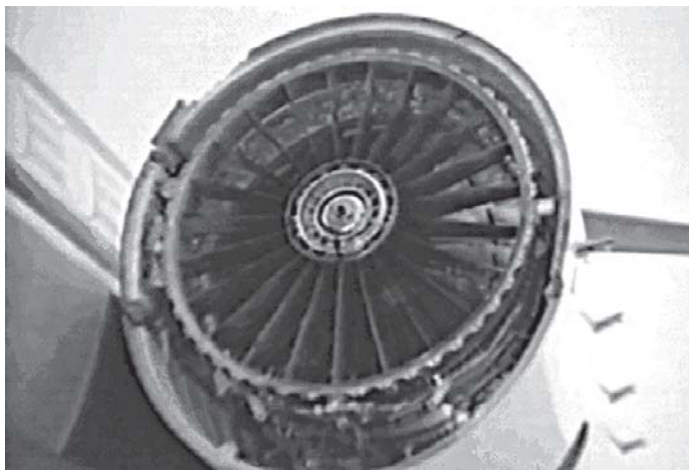

Figure 1

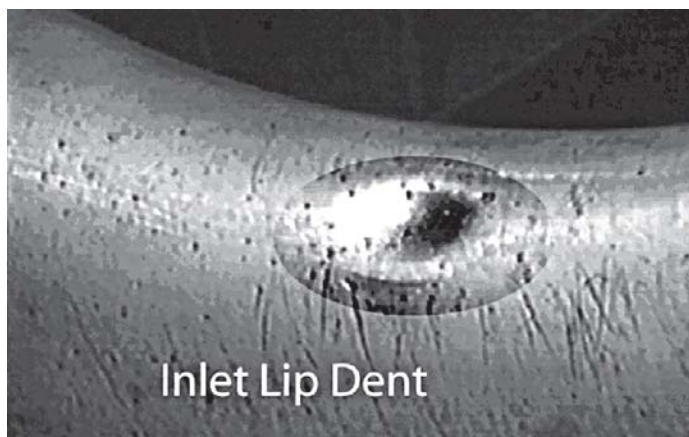

Figure 2

observed by the flight crew. Weather radar and ice detectors installed on aircraft are generally ineffective in detecting ice particles, so the crew may not be able to avoid this kind of engine icing conditions.

### Investigative techniques

The real challenge to the investigator of malfunctioning engine incidents is to recognize that ice in any form was involved. The actual ice has almost always melted by the time that the investigation has even begun. The investigator must then unearth clues and follow a path of inference between cause and effect.

The typical investigation proceeds as an initial collection of facts, many of which are observational such as visible damage to the aircraft and/or engines, location, and relative timing of events. Other information would be obtained from documental evidence such as weather maps and advisories, ATC radar plots, CVR and DFDR readouts, maintenance, and flight logs, etc.

In the case of a hail encounter, the most obvious evidence is the observation of body damage to frontal surfaces of the aircraft, including radomes, windscreens, engine inlets, and/or fan blades. However, when assessing the possible consequences of such events on the propulsion system, it should be noted that neither a positive nor negative finding of soft-body damage to the frontal surfaces is sufficient to prove or disprove a serious effect on powerplant operation. In fact, there is little historical evidence that visible hail damage on a gas turbine engine has caused a significant power

loss. Instead, as in the case of any weather-related considerations (including ice crystals at altitude), the investigators should consider that primary damage may not be present on the engines. It is important to stress that in this case “primary damage” refers to significant soft-body damage affecting the compressor system. Any thermal damage to the turbine should normally be considered as secondary to the initial ice-related damage and may well be due to the inability of the crew to recover from the initial malfunction caused by the primary damage.

The analytical results of matching the estimated environmental and operational conditions associated with the accident (quantity of water or hail, altitude, and power being delivered) against the expected engine performance limitations and crew actions would likely lead the investigating team to conclude if an ice-related causal chain is consistent with the findings.

According to the outcome of the investigation, the resulting recommendations would address any unsafe condition in icing weather detection and avoidance, crew response to ice-related powerplant malfunctions, and/or tolerance of the engine to the expected environment.

### Summary of relevant investigations

A number of engine ice-related investigations are summarized in this section. For each event, some factual information will be given, along with a description of the observed damage, the probable cause, and possible risk control measures. The primary aim is to help investigators by pointing out some areas of consideration when ice is suspected as a cause and by giving some guidance for the observation of damage on engine parts.

The events presented do not include severe weather (hail/rain) encounters. The discussion of this threat would focus mainly on engine performance and certification issues rather than on damage observation and analysis, which is the subject of this paper.

#### EVENT 1

**Factual information:** On an aircraft with tail-mounted engines, the pilot reported a loud bang in cruise, followed by engine winding down and continued vibration for remainder of the flight. During approach, a low-fuel warning light occurred. On arrival, fuel was reported leaking down the aft staircase.

**Observed damage:** Inlet cowl missing, engine nose bullet missing, numerous fan blades missing (see Figure 1). When the inlet cowl was recovered, a dent was observed on the lip (see Figure 2). Investigation revealed streaking along forward fuselage and log-book writeups of broken landing lights and/or dented inlet cowls.

**Probable cause:** Ingestion of large block of ice from leaking forward lavatory.

**Key pointers:** Single engine involvement on the trajectory of the potential fuselage leak. Observation of leading edge damages (wings, stabilizer, inlet cowl, engine nose bullet, etc.) located in line with the leakage source.

**Risk control measures:** Address potential fuselage leakage if soft-body leading edge damage is found on aircraft surfaces.

#### EVENT 2

**Factual information:** Just after takeoff, as gear was raised, a loud thump was heard, followed by engine winding down. Aircraft had

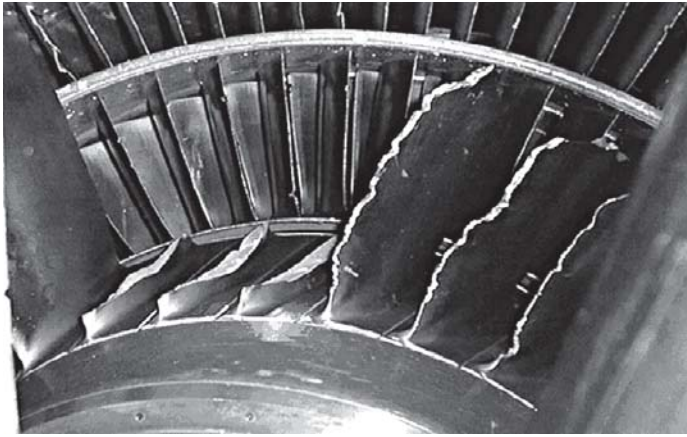

Figure 3

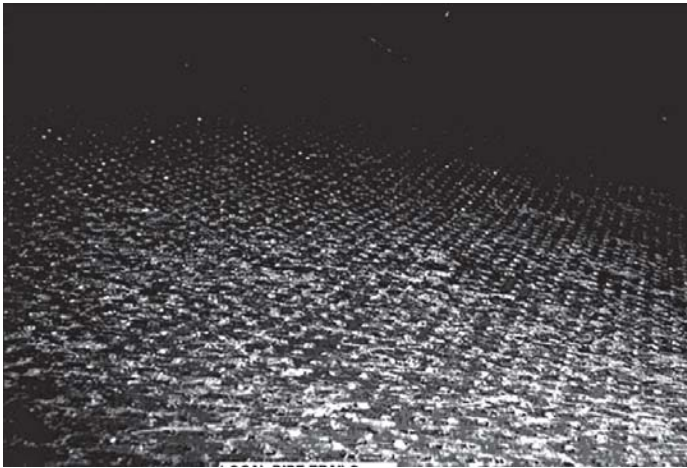

Figure 4

taken off several hours after a snow storm at airport.

**Observed damage:** After the air-turn-back, one engine was observed with crushing damage to the inlet cowl and numerous missing fan blades (see Figure 3). Dirt was found trapped in sound proofing holes in fan area (see Figure 4). An engine nose bullet buckle was crushed (see Figure 5), and white stains were observed on the compressor vanes (see Figure 6). The other engine had moderate leading edge dents and curls.

**Probable cause:** Slush shed off the gear at retraction after take-off and was ingested by the engine.

**Key pointers:** Multiple engine involvement in takeoff regime following snowstorm. Crushing damage ahead of fan, dirt and staining in fan-compressor area.

**Risk control measures:** Inspect gear prior to dispatch for slush buildup. Be mindful of taxiway slush ridges.

### EVENT 3

**Factual information:** This type of event is characterized by several occurrences in the same time frame, often same day, same aircraft model, usually associated with snow storm conditions. During takeoff or flight, the flight crew reported engine stall/surging to one or more engines.

**Observed damage:** Borescope investigations or engine teardown examinations at scheduled overhaul revealed tip curl/dents/cusp in the forward stages of the aft compressor (high-pressure) spool



Figure 5



Figure 6

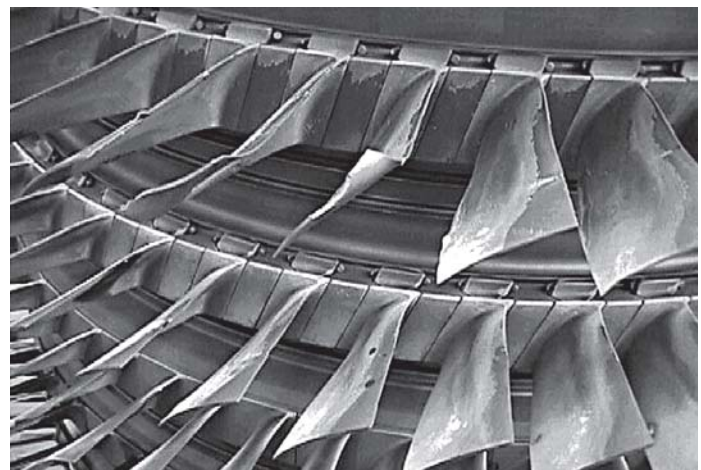

Figure 7

**Probable cause:** Ice that formed in front of engine at low power was released at takeoff and was ingested into the high-pressure section, resulting in damage to the blades of the first stages.

**Key pointers:** Multiple events, involving engines in same fleet and in same time frame. History of operation showed that the engines were run at low power in snowing/icing conditions, typically on ground. Soft-body damage originated in forward stage





Figure 8

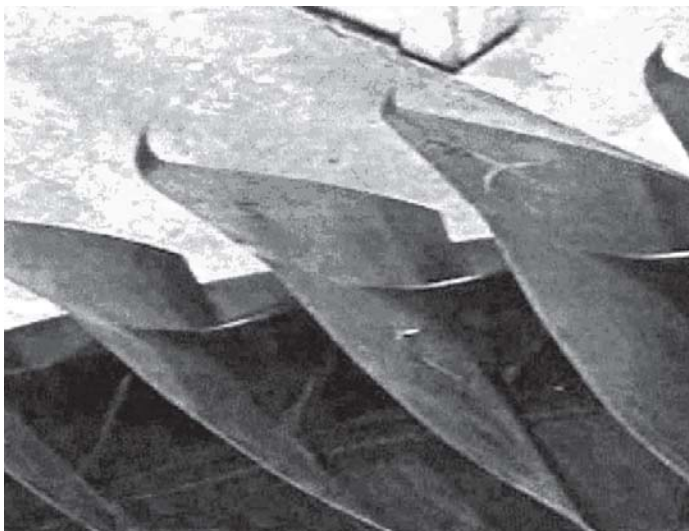

Figure 9

of high-pressure spool. Onset of symptoms is often associated with takeoff and an inflight stall/surge.

**Risk control measures:** Adhere to recommended fan spool-ups to shed ice in front of engine before high power operations.

#### EVENT 4

**Factual information:** Multiple complaints of vibration or fan noise and walk around findings of minor damage at engine inlet. The events involved engines of the same fleet in same time frame.

**Observed damage:** Small dents to acoustic material in front of fan (see Figure 8) and at tips of fan blades (see Figure 9).

**Probable cause:** Ice accretion on spinner shed during spool-up from low power to high power. The ice impacted the inlet both ahead of and slightly intersecting the fan blades, depending on the local airflow conditions at the instant the ice was shedding.

**Key pointers:** Soft impacts both ahead of fan and just at fan tips following operations in fresh snow conditions.

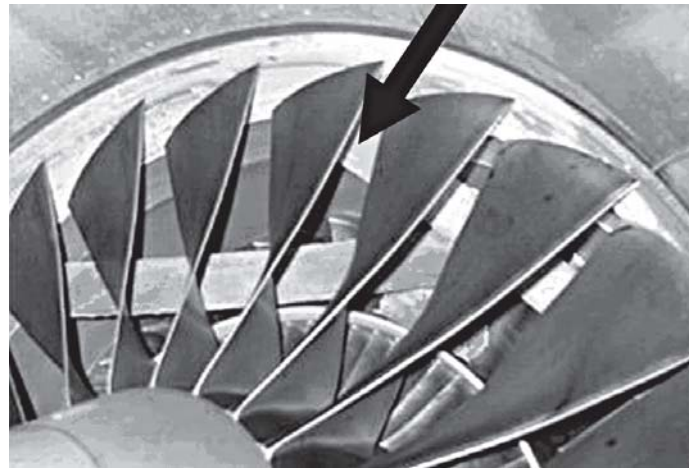

Figure 10

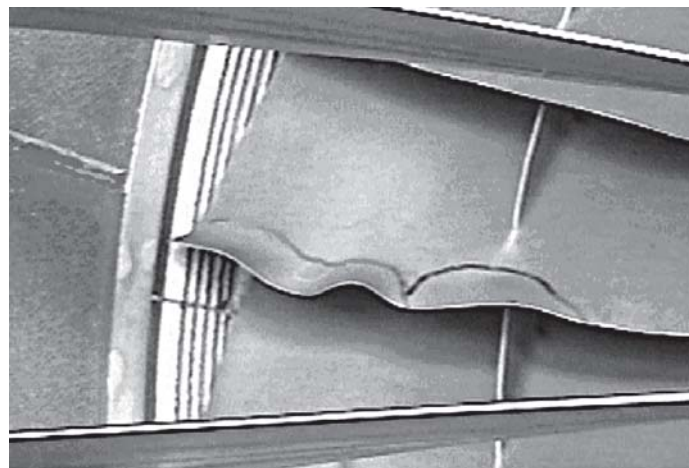

Figure 11

**Risk control measures:** Adhere to recommended procedures regarding periodic spool-ups of fan to shed ice in these conditions.

#### EVENT 5

**Factual information:** During a low-power approach in snowy conditions, the engines were spooled up for landing. All engines initially spooled up but then sustained a permanent power loss.

**Observed damage:** Pre-impact damage found to outer case liner behind the fan (see Figure 10).

**Probable cause:** Fan blade ice shed while transitioning from low power to high power in flight. Fan blade ice was pumped rearward due to the twisted shape of the fan blades.

**Key pointers:** Damage is just aft of fan at the outer wall. The engine had transitioned from low power to higher power while operating in snowy or severe icing conditions.

**Risk control measures:** Increase the minimum RPM for low power operation in icing conditions and/or perform more frequent spool ups to shed ice.

#### EVENT 6

**Factual information:** During the first flight of the day, following overnight layover in near-freezing conditions, multiple engines stalled/surged just after rotation.



**Observed damage:** All engines were found with moderate random soft-body damage. Ripples (see Figure 11) and corner rubbing (see Figure 12) were observed on fan blades.

**Probable cause:** Sheet ice ingestion from aircraft surface ahead of engine.

**Key pointers:** leading edge ripples, random soft damage, overnight standing in freezing precipitation. Multiple engines involvement.

**Risk control measures:** Hands-on pre-flight check after deicing.

#### EVENT 7

**Factual information:** The aircraft was flying above 26,000 feet in icing conditions. On all 4 engines, the high-pressure spool speed rolled back to 40-45%. The crew shut down Engines 1 and 2 due to rising turbine gas temperature. Engine 2 was restarted and recovered, as did engines 3 and 4.

**Observed damage:** No damage was found in the compressor. The turbine section showed thermal damage.

**Probable cause:** Encounter with ice particles and inadequate tolerance of the engine to such threat.

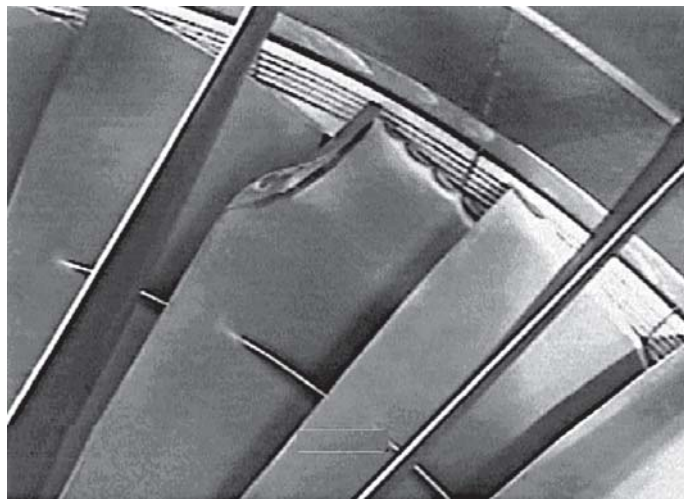

*Figure 12*

**Risk control measures:** Restrictions on the operating environment for unmodified engines. Modifications on the engine to eliminate the phenomenon. ♦

# Turbine Engine Risk Management In the U.S. Air Force

By Richard P. Greenwood, Pratt & Whitney



**Richard Greenwood** is a flight safety investigator for Pratt & Whitney assigned to the Air Force Safety Center at Kirtland Air Force Base, Albuquerque, N.M. He has a bachelors degree in aerospace engineering from Embry-Riddle Aeronautical University and a masters degree in air safety from Embry-Riddle Aeronautical University. Greenwood

has been a Pratt & Whitney engineer for 30 years and a Pratt & Whitney accident investigator for 13 years with more than 35 on-site investigations covering C-17, E-3, F-15, F-16, F-14, F-111, T-6A, and F/A-22 aircraft, both foreign and domestic. He has a commercial pilot certificate with instrument and multiengine ratings and is an airframe and powerplant mechanic with inspection authorization. He is a Federal Aviation Administration master parachute rigger and a designated parachute rigger examiner and is a United States Parachute Association tandem and accelerated freefall instructor.

**H**istorically, engine failures account for about 25% of all United States Air Force (USAF) flight-related Class A and B mishaps and are the second highest driver in mishap costs. They may be due to design issues, maintenance errors, operational factors, or changes in the aircraft's mission from its original design specifications. They can be known problems or first-time occurrences. This paper will explain how the USAF manages its engine fleets to ensure engine problems are corrected in a timely and properly prioritized manner to gain the maximum amount of risk reduction from taxpayers' dollars while maintaining fleet readiness.

The risk management process is a team effort of the USAF and the engine manufactures. Both bring specialized expertise, information, and insight to the process. The Air Force director of propulsion (DOP) is responsible for instituting and maintaining the risk management process.

Accidents or "mishaps," as the USAF calls them, are divided into four classes depending on the amount of damage, total mishap cost, or extent of injury to personnel.

**Class A mishap**—A mishap resulting in one or more of the following:

- Direct mishap cost totaling \$1,000,000 or more.
- A fatality or permanent total disability.
- Destruction of a DOD aircraft.

**Class B mishap**—A mishap resulting in one or more of the following:

- Direct mishap cost totaling \$200,000 or more but less than \$1,000,000.
- A permanent partial disability.
- In-patient hospitalization of three or more personnel. Does not count or include individuals hospitalized for observation, diagnostic, or administrative purposes who were treated and released.

**Class C mishap**—A mishap resulting in one or more of the following:

- Direct mishap cost totaling \$20,000 or more but less than \$200,000.

There are also Class E "events." These are occurrences that do not meet reportable mishap classification criteria but are deemed important to investigate/report for mishap prevention. Class E event reports provide an expeditious way to disseminate valuable mishap prevention information. In the propulsion arena, a Non-Recoverable Inflight Shutdown (NRIFSD) or an Inflight Shut Down is classified as a Class E event. The USAF records all propulsion-related mishaps and events, and uses Class A mishaps and NRIFSDs to manage risk levels.

Once a mishap or event occurs, the risk management process proceeds through three phases

1. Issue/problem identification phase,
2. Interim risk management phase, and
3. Solution development/implementation phase.

Let's look at each one individually and see how they work.

## 1. Issue/problem identification phase

An initial problem report may surface from several different sources. Mishap investigations, pilot write-ups, deficiency reports, Lead the Fleet Programs, foreign military fleets, or original equipment manufactures reports and tests are the usual sources of information. Once a problem is identified, a thorough investigation must be performed to get to the root cause of the problem. For example, a broken compressor blade might be traced to a misrigged compressor vane actuator. This is not the root cause. Why was the actuator misrigged? Was there a design problem that allowed misrigging? Are the tech data insufficient? Was the mechanic properly trained? Was he given the correct tools? Some or all of these questions may need to be answered to get to the root cause so proper corrective action may be instituted.

During this phase, data are usually gathered to help define the problem. Both the USAF and the engine manufactures keep databases of engine incidents. In cases where USAF engines share common hardware or components with civil aircraft, those databases may also be queried. Time compliance technical orders (TCTOs) may be issued on certain suspect engines to inspect them with the aim of determining exactly what and how widespread the problem may be. Engine or lab tests may need to be performed. Batches of hardware may be inspected. Overhaul and assembly practices might be reviewed. All these processes are aimed at gathering as much data as possible about the problem so analysts can zero in on the root cause.

Once the root cause is identified, a risk assessment is performed to ascertain the risk of continued operation to the fleet. The risk may be only to a small subpopulation of a particular model en-

gine. An example of this would be if an improper heat treat were done to a particular batch of parts because of a faulty heat-treat oven. The risk may be spread out over many different engine models. An example of this would be if many different engines were serviced with a contaminated batch of oil. In any case, the population of engines at risk must be bounded and the projected number of hours these engines are going to fly for the life of the fleet determined. A historical records search is also performed to find other similar incidents that may have occurred. Once the root cause is identified and the population of suspect engines bounded, a statistical analysis is performed to estimate the future rate of occurrence for the problem under investigation.

There are several different statistical tools used to predict future risk. The Weibull analysis and Monte Carlo analysis are two of the most common. The choice of which to use depends on the nature of the problem. A Weibull (named after Waloddi Weibull, a Swedish engineer, scientist, and mathematician) can be used as a good first cut tool when not much is known about the problem and there have been very few (maybe just one) failures. It can predict if a risk of failure decreases with age (such as in an initial quality problem), stays constant with age (indicating a random failure), or increases with age (indicating fatigue or wear-out modes). The goal is to predict the probability of failure over time. A Weibull analysis not only uses failure data, but also success data.

A Monte Carlo analysis can best be used when there are many variables affecting the problem, and the variables need to be manipulated to see the effect on risk reduction. The variables may be production tolerances, instrumentation data handling, test schedules, control trims, unscheduled maintenance activities, probabilities of detection, human error rates, etc. All the variables are given a random occurrence factor and the simulation run over and over, thousands of times, if necessary, to give a predicted rate of occurrence. The more variables, the more randomness, the better it works.

Severity factors are then used to define the probability that an event may result in a safety incident. It is based on historical data. For example, we know by analyzing past events that when an F-16, a single engine fighter, has a NRIFSD, 79% of the time that will result in a destroyed aircraft (Class A mishap). Example: There were four compressor blade failures in an engine fleet from a high-cycle fatigue failure mode. If none of them resulted in a NRIFSD, an assumption would be made that the next one would, resulting in a severity factor of 1/5. If the Weibull analysis predicted 20 more blade failures over the life of the fleet, we would apply the severity factor and predict four NRIFSDs over that time.

Regardless of the method used, the idea is to predict how often the particular failure mode will occur in the future.

Once the method is chosen, the analysis can be "calibrated" or compared to actual experience. If, for example, the analysis predicts that five events should have occurred by now, but there has been only one, then some of the assumptions made in the analysis may be incorrect and need further refinement.

Once the number of predicted failures is calculated, the weapons

system flying hours estimated is used to calculate failure rates. Continuing with the example above of four predicted NRIFSDs from the compressor blade fatigue failure, if the predicted flying hours (drawn from USAF data) is 300,000 hours, the NRIFSD rate would be 4/300,000, or 1.3 NRIFSDs/100,000 flying hours. If the engine was in an F-16, we would also calculate the number of future Class A mishaps (destroyed aircraft). Using the 79% severity factor, that would be 3.16 future Class A mishaps over the life of the weapons system.

There are three threshold values used in the USAF to manage risk. Two are based on Non-Recoverable Inflight Shutdowns (NRIFSD) and the other on Class A mishaps. The NRIFSD thresholds for aircraft with one or two engines are 0.01 and 0.05 NRIFSDs per 100,000 flying hours (computed over the life of the weapons system). The thresholds are 0.05 and 0.10 for three or more engine aircraft. The Class A threshold for all aircraft is 0.5 Class As until the next inspection/repair opportunity. The required corrective action depends on what the NRIFSD rate or number of Class As is predicted by the risk analysis. For example, if a risk analysis for a specific problem predicts less than 0.01 NRIFSDs and less than 0.5 Class A mishaps (one or two engine aircraft), the program manager is only required to review the problem. If the risk analysis predicts between 0.01 and 0.05 NRIFSDs, the program manager will monitor the situation and has the option of implementing some type of corrective action. When the risk analysis predicts a NRIFSD rate of greater than 0.05, some type of corrective action is required to reduce the projected risk to below that threshold. Table 1 summarizes the current risk thresholds and required actions. The NRIFSD threshold tends to protect smaller fleets while the Class A threshold tends to protect larger fleets. The corrective action must be sufficient to drive the risk below the established threshold. (It should be noted that due to the cost of maintenance and repair of engines and inflationary drivers, there are a growing number of Class A mishaps that do not result in the loss of an aircraft.). Obviously, in our example of a compressor blade fatigue problem, we are over both thresholds and corrective action is required.

## 2. Interim risk management

If the problem turns out to be a basic design issue with a component, the solution might be a redesign and retrofit of the fleet. In some cases, this could take years to accomplish. This is where the concept of interim risk management comes into play. What can be done NOW to reduce the risk? This usually comes in the form of inspections or operational restrictions. These temporary solu-

SINGLE/TWIN ENGINE	MULTIENGINE (3 OR MORE)	REQUIRED ACTION
< .01/100K EFH	< .05/100K EFH	REVIEW
.01 - .05/100K EFH	.05-.1/100K EFH	MONITOR
> .05/100K EFH	> 0.1/100K EFH	CORRECTIVE ACTION REQUIRED
>0.5 CLASS As PRIOR TO NEXT OPPORTUNITY	>0.5 CLASS As PRIOR TO NEXT OPPORTUNITY	CORRECTIVE ACTION REQUIRED

**Table 1. NRIFSD and Class A Threshold Values**



tions are put in place until a final solution to the problem is developed. If a certain rate of inspection or hardware incorporation is determined necessary to keep the risk below threshold values, then it is important to monitor the issue to be sure the rate is correct. If incidents continue to occur, or inspection finds determine the rate of occurrence is greater than initially anticipated, the inspection/incorporation rate may have to be increased.

For our compressor blade example, if the high-cycle fatigue was found to be driven by a particular portion of the flight envelope, a flight restriction to avoid that part of the envelope might be appropriate. If there were variable vanes in front of the failing compressor blade controlled by an electronic engine control, a software change modifying the vane angle at in the damaging portion of the flight envelope could supply some interim risk mitigation. For a low-cycle fatigue issue, periodic borescope inspections for the compressor blade might be in order.

**3. Solution development/implementation phase**

This final phase concentrates on the methods needed to return all engines to service without the need for operational restrictions or interim inspections. This can be a multiyear/multimillion dollar project or a simple technical order (TO) change depending on the problem. It is usually in the form of retrofit of redesigned hardware or revised assembly practices.

When hardware redesign is required, the engine manager will be tasked to come up with a cost-effective fix. The redesign effort will usually fall to the engine manufacturer, under the Component Improvement Program (CIP) contract. Here, the CIP task will be reviewed and “stacked” against other issues for funding. If other problems are determined by the CIP manager to be of a higher priority, due to higher risk or better cost effectiveness, the redesign may be delayed until more funding is available. In that case, the interim risk reduction actions will have to continue. However, tracking of the effectiveness of the interim actions must continue to be sure they maintain their calculated level of risk mitigation. If not, the risk may rise to such a level that a reevaluation of the CIP stacking might be required.

When CIP funding is in place, the redesign effort goes full-speed ahead. The contractor’s redesign effort is coordinated with the Air Force engine specialists to be sure it meets the needs and will correct the problem. Lab tests, ground engine tests, flight tests, and/or field service Evaluations may be required before a retrofit is begun.

During the introduction phase of the hardware retrofit, the engine manager will most likely make use of the “Lead the Fleet” Program. This USAF Program selects certain engines to be designated as high-usage engines. The field units make every effort to keep these engines flying in order to accumulate a high amount of operating time as quickly as possible. Having the redesigned hardware in Lead the Fleet engines will ensure that any potential

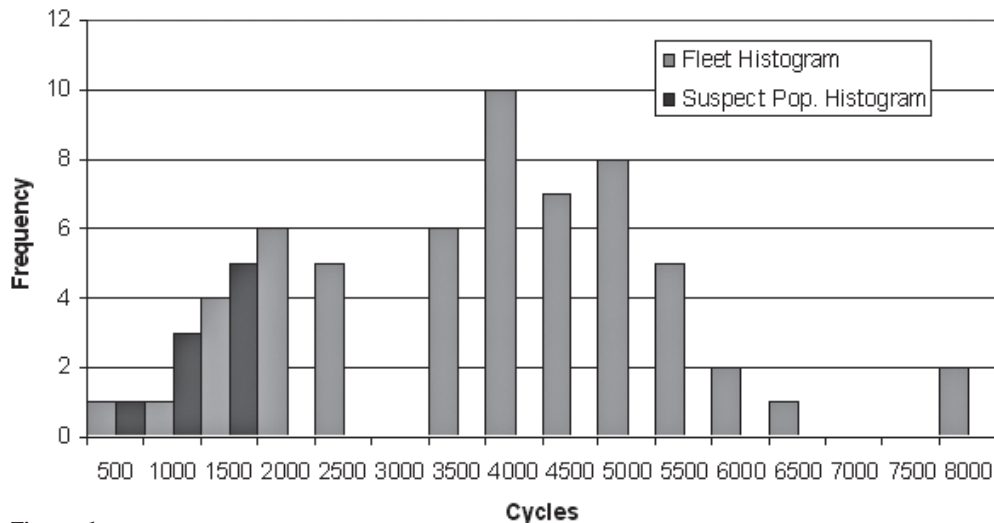

Figure 1

<b>Remaining CCY</b>	<b>Remaining EFH</b>
474,576	237,288

Table 2

shortfalls in the redesign will become apparent early on, prior to their manifestation in the rest of the fleet.

Again, throughout the retrofit phase the problem needs to be monitored to ensure the fix is working and the rate of incorporation is sufficient to keep the risk below threshold.

As can be seen, it can be a long process from problem identification to a fielded solution. All these steps are required to keep the risk to the fleet at a minimum while getting the most bang for the buck out of the taxpayers’ dollars.

The following is a sample risk assessment showing how all these factors are brought together to make the decision of what action is required to keep a risk of continued operation below Air Force established threshold values.

**Introduction**

Two Recent World Air Force (WAF) safety incidents related to fractured “D” stage vanes has prompted an investigation into the root cause of these failures in order to prevent future safety events. The results of this investigation led to the conclusion that a batch problem exists with a series of WAF engines, which are experiencing a higher wear out rate than the balance of the WAF fleet.

Engine E0009 experienced an IFSD in August 2002 with 1,591 total accumulated cycles (Ccy). Shortly thereafter, E0010 experienced a NRIFSD with 1,252 total cycles accumulated. These failures and subsequent research indicated a process error, which affects a batch of WAF engines (E0009 to E0019). This has shown that a portion of the WAF fleet is exposed to increased safety risk. This risk assessment is performed to quantify the risk to the WAF

and provide recommendations to bring the WAF risk below safety thresholds.

**Population at risk/exposure to risk**

The population at risk is all WAF engines that have received suspect vanes. Based on a records search, it has been determined that suspect parts have been installed in WAF engine serial numbers E0009 through E0019. These engines are exposed to risk of failure until the suspect parts are removed from these engines.

The Weapon System Life for the WAF is calculated based on the following information provided by the WAF:

- WAF average fleet fly rate: 25 cycles per Month and 2 cycles per engine flight hour (EFH).
- WAF assumed engine retirement age: 12,000 cycles.
- WAF total accumulated cycles: see attached histogram (Table 2).

**Historical data**

A search of the System Safety Database has shown that throughout the history of the WAF engine program, there have been four vane failures (including the most recent failures in E0009 and E0010). Of these four failures two have resulted in NRIFSDs (Table 3).

**Severity factor**

The severity factor for this risk assessment is based on the historical information presented in the historical data section of this risk assessment.

Of the four cases of vane failure, two have resulted in NRIFSDs. Therefore, the assumption is made that 2/4, 50%, of vane failures will result in NRIFSD's. Additionally, the historical Class A mishap severity factor of .79 is used to calculate the number of Class A mishaps resulting from NRIFSDs.

**Risk prediction tool**

The risk prediction tool used in this assessment of fleet risk for the failure mode related to "D" stage vanes is a straightforward Weibull analysis.

The two failure engines were sister engines, and an investigation was performed to determine if a batch issue was present. It was concluded that a process change was made during the time period that included engines E0009 to E0019. Based on this information, a Weibull analysis was performed on only these suspect engines. This analysis yielded the following Weibull parameters:  $\beta = 2.01$  &  $\eta = 5,569$  (Figure 2).

The total risk of continued operation of the at risk engines was calculated based of three scenarios.

- Baseline (do nothing) risk of operating the engines to their full 12,000 Ccy life.
- Replacing the suspect vanes at the Next Scheduled Depot Visit

Engine Serial Number	Date of Occurrence	Cycles on Engine at Time of Occurrence	Component Causing Occurrence	Result
E0026	June 1995	563	"B" stage Vane	NRIFSD
E0050	February 1999	4473	"A" stage Vane	IFSD
E0009	August 2002	1591	"D" stage Vane	IFSD
E0010	August 2002	1252	"D" stage Vane	NRIFSD

Table 3

**Weibull Plot (Example Risk Assessment One)**

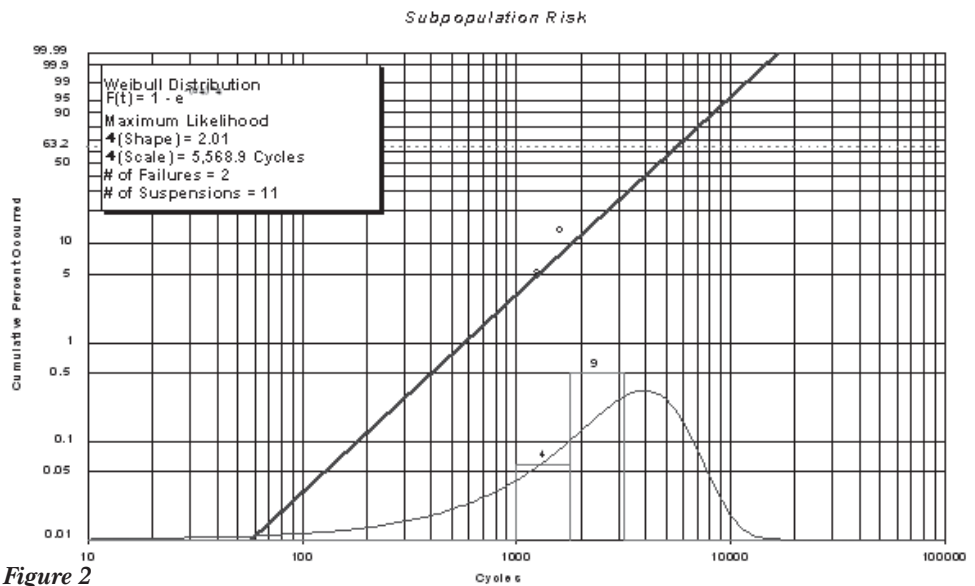

Figure 2

(NSDV) of 4,000 Ccy.

- Replacing the suspect vanes in a rapid retrofit program before they accumulated 160 additional Ccy.

The next table shows the calculations of number of future expected failure for the 4,000 Ccy NSDV situation based on the above Weibull plot. Calculations for the baseline and 160 Ccy retrofit schedules are similar.

Engine S/N	Current Vane Time	Vane Ccy at Depot	Current Vane Ccy F(X) from Weibull	4,000 Ccy Depot Visit F(X+a) from Weibull	4,000 Ccy F(X+a)-F(X)/(1-F(X))
E0009	1591				
E0010	1252				
E0011	2474	4000	0.1778	0.402	0.2727
E0012	2668	4000	0.2038	0.402	0.2490
E0013	2751	4000	0.2152	0.402	0.2381
E0014	2614	4000	0.1964	0.402	0.2559
E0015	2555	4000	0.1885	0.402	0.2631
E0016	1970	4000	0.1165	0.402	0.3232
E0017	2219	4000	0.1456	0.402	0.3002
E0018	2284	4000	0.1536	0.402	0.2935
E0019	2538	4000	0.1862	0.402	0.2652

Total Expected Failures: 2.4609

**Calculations**

The application of the Weibull parameters to the WAF fleet information yields the following predicted number of failures (Figure 3, following page).

**Summary of results**

Fleet Management Scenario	Number of Vane Failures	Number of NRIFSDs	NRIFSD Rate per/100K EFH	Class A Mishaps
Baseline Risk	8.88	$8.88 * 0.50 = 4.44$	$4.44 * 100,000 / 237,288 = 1.87$	$4.44 * 0.79 = 3.51$
Retrofit at NSDV	2.46	$2.46 * 0.50 = 1.23$	$1.23 * 100,000 / 237,288 = 0.52$	$1.23 * 0.79 = 0.97$
Rapid Retrofit (160 Ccy from current)	0.24	$0.24 * 0.50 = 0.12$	$0.12 * 100,000 / 237,288 = 0.049$	$0.12 * 0.79 = 0.09$

Figure 3: Fleet management scenario.

The above risk summary shows the risk to the WAF fleet for various fleet management scenarios:

1. Baseline Risk—No corrective action to Weapon System Life (WSL).
2. Retrofit at Next Scheduled Depot Visit (NSDV)—Replace current suspect parts when the suspect engine is returned to depot.
3. Rapid Retrofit—Replace current suspect parts when the suspect engine has accumulated an additional 160 cycles from its current total accumulated cycles.

Based on the assumptions made in this risk assessment, a rapid retrofit schedule is required to reduce WAF fleet risk to below threshold limits (0.05 NRIFSDs per 100K EFH and/or 0.5 Class A mishaps). All the engines with suspect vanes will be required to have them replaced before accumulation an addition a160 Ccy of operation.

**Calibration**

Based on the methods and assumptions used in this risk analysis,

the Weibull analysis would have predicted nearly 1.8 failures to date, 0.9 NRIFSDs and 0.7 Class A mishaps. These values correlate very well with the experience of 2 failures, 1 NRIFSD, and 0 Class A mishaps.

**Definitions (AFMAN 91-223)**

**INTENT FOR FLIGHT**—Intent for flight is considered to exist when aircraft/UAV brakes are released and/or takeoff power is applied for commencing an authorized flight. Intent for flight continues until either the fixed-wing aircraft/UAV taxis clear of the runway or, for helicopters and/or vertical takeoff and landing aircraft, the aircraft has alighted and the aircraft weight is supported by the landing gear. Clear of the runway means the entire aircraft/UAV is physically off the active runway. Hover taxi is considered flight.

**INFLIGHT SHUTDOWN (IFSD)**—Any engine shutdown inflight, either due to an engine malfunction or by the aircrew following flight manual procedures.

**NON-RECOVERABLE INFLIGHT SHUTDOWN**

—Any engine shutdown in flight, either due to an engine malfunction or by the aircrew following flight manual procedures whereby the engine is unable to restart, or further investigation determines that a restart attempt would not have been successful, or further investigation determines that continued operation would have caused the engine to fail, or the aircraft cannot maintain level flight at a safe altitude as determined by the situation. ♦

**References**

United States Air Force. (Feb.14, 2006). *Safety Investigations and Reports* (Air Force Instruction 91-204). Retrieved from <http://www.e-publishing.af.mil/shared/media/epubs/AFI91-204.pdf>.  
 United States Air Force (July 6, 2004, Incorporating Change 1, Aug. 9, 2006) *Aviation Safety Investigations and Reports* (Air Force Manual 91-223). Retrieved from <http://www.e-publishing.af.mil/shared/media/epubs/AFMAN91-223.pdf>.  
 United States Air Force (June 10, 2003) *Best Practice PCOE BP 99-06 Rev C* ASC/LP & OCALC LP. Retrieved from <http://propulsion-best-practices.wpafb.af.mil/>.



# A Review of Rapid Changes in General Aviation and Their Likely Effect on GA Safety in Four Countries

By Robert Matthews, Ph.D., Office of Accident Investigation, Federal Aviation Administration, USA



*Bob Matthews has been with the FAA since 1989, where he has been the senior safety analyst in the Office of Accident Investigation for the past 13 years. His previous professional experience includes 9 years in national transportation legislation with the U.S. Department of Transportation, 2 years as a consultant with the European Union and the Organization of Economic Cooperation and Development in Paris, and several years as an aviation analyst for the Office of the Secretary at the U.S. DOT. His academic credentials include a Ph.D. in political economy from Virginia Tech's Center for Public Administration and Policy Analysis, and he has been an assistant professor, adjunct at the University of Maryland since 1987.*

The air taxi industry and large segments of general aviation (GA) are undergoing rapid and fundamental technological change for the first time in several decades, with the broadly-based introduction of glass cockpits, a sustained increase in the business jet fleet, and the introduction of new microjets or "very light jets" (VLJs). This paper initially set out to show how significantly these changes will improve overall GA safety in four countries with large GA systems by reducing the frequency of certain types of accidents that tend to have severe outcomes. However, the paper reaches more modest conclusions. The bottom line remains that the technological changes will substantially improve overall safety but with more caveats than were initially anticipated.

This paper analyzes fatal GA and air taxi accidents from Australia, Canada, the United Kingdom, and the United States to estimate the degree to which the increased application of new technology will affect GA safety in each of the four countries. The analysis uses accident data and accident investigation reports from the four countries as its primary source material. The paper is based on a methodology that mapped several key characteristics of the new technology to each fatal accident in each of the four countries. The central conclusions are as follows.

Overall, GA safety will improve significantly as glass cockpits enter the GA fleets at an accelerating pace and as very light jets (VLJs) start to enter the fleet in large numbers among air taxis, business operators, and the upper end of the private pilot market. Simultaneously, the corporate jet fleet will continue its rapid growth in all four countries. These trends will enable GA to leapfrog several generations of foregone technological advances in aviation and begin to close the gap with air carrier safety.

However, large portions of GA activity, and of GA fatal accidents, will prove to be immune to much of the innovation. Si-

multaneously, the improvements offered by glass and by VLJs will be partly offset by new risks and by some new patterns.

Other changes also will improve overall fatal accident rates even if rates remain unchanged within the various populations and activities captured by the label of "GA." Demographic changes and the effects of price likely will reduce activity among many less-experienced pilots and among riskier types of flight. Conversely, with the technological expansion noted above, those populations and flight activities that generally have relatively good accident records will expand in absolute terms and especially in relative terms. Consequently we may compute and report lower fatal accident rates

However, despite these caveats, the primary conclusion is that technological changes that are well under way will substantially improve net GA safety. The real caveat is that the net benefits will be realized incrementally rather than in a one-off revolution in safety.

## Changes in the demographics of general aviation in four countries

Fatal accident rates in general aviation<sup>1</sup> have improved incrementally for years from better powerplants, improved air traffic services, better weather information, and other improvements. Yet, for the most part, GA has been denied the rapid and repeated breakthroughs in safety that technology has brought to the air transport industry. Instead, with the exception of the very high end of the market (corporate jets), most of GA continued to operate with a badly dated technological base, with carburetor-based piston engines, limited onboard information, limited communications, etc.

## Changes in the fleet

The primary explanation for the technological stagnation rests with the long-term collapse in the production of new, light aircraft that began after 1978 and continued into the latter 1990s. Factors included the continued exposure of U.S. manufacturers to product liability claims in accidents involving small GA aircraft decades after they were produced. Other factors included higher fuel costs, higher landing fees and other user charges in many regions, plus improved travel alternatives, the loss of GA airports, demographic changes, and a glut on the market from some excess production during the "good days."

The General Aviation Manufacturers Association notes that shipments of GA aircraft by U.S. manufacturers peaked at nearly 18,000 in 1978, with nearly 14,000 deliveries to the domestic market and 4,000 delivered abroad. Deliveries collapsed to just

2,000 by 1983 and were well below 1,000 by 1993, when just a bit more than 400 aircraft were delivered to domestic buyers. With the exception of some advances by some aircraft kit manufacturers and the delivery of business jets, GA experienced virtually no fleet turnover for 20 years.

Data from Australia make the point rather dramatically. In a report to its Parliament in 2006, the Australian Department of Infrastructure, Transport and Regional Development reported that from 1994 to 2004, the average age of the GA fleet increased 10 years. In short, the fleet remained essentially static and simply aged in place.

Hope finally began to emerge when the U.S. Congress responded with the General Aviation Revitalization Act of 1994. Allowing for the necessary time to build orders and to rebuild production facilities and processes, the industry began to recover by 1997 and 1998. Though U.S. production will never approach 18,000 units per year again, the new production has added more and more technology to its products as the market has recovered.

The technology began with glass cockpits being offered as options on smaller GA aircraft and as retrofits for existing aircraft. Today most new production is available only with glass. Simultaneously, the market for business jets experienced unprecedented growth beginning about the mid-1990s. In addition, very light jets, or microjets, were being designed and are now entering the market. Though some pilots may prove to be ill-prepared for VLJs or for glass cockpits, thereby increasing their personal risk, the net effect of these changes will be positive and substantial.

### Glass cockpits

The FAA defines a “technologically advanced aircraft” (TAA) as having at least a moving map, an IFR-approved GPS navigator, and an autopilot. The Aircraft Owners and Pilots Association (AOPA) notes that glass-cockpit aircraft are a subset of TAA. AOPA notes that “glass” adds at least a primary flight display (PFD) and a multifunction display (MFD); graphic depiction of complex airspace; displays of other transponder-equipped traffic; the possibility of onboard weather radar or virtually real-time weather information via data link; airport maps and navigational charts; flight directors that improve the precision of flight; 6-second trend indicators that project speed, altitude, vertical speed and attitude; fuel warning displays; and new FADECs that have eliminated the need to manage prop RPMs or fuel mixture.

With this equipment, the cockpit of the once-humble single-engine reciprocating aircraft now offers functions that are similar in concept to those that not long ago were reserved for airliners and the upper end of the business jet market. While much of the equipment may not be directly comparable to equipment that is certified for new airliners, the net effect is much the same—workload is significantly reduced and situational awareness is significantly improved.

The effects on safety also should compare well to the effects that automation and technology have had on air carrier safety. Glass-cockpit GA aircraft should experience lower frequencies of accidents involving controlled flight into terrain (CFIT), less inadvertent flight into severe weather or inadvertent visual flight into instrument conditions, lower rates of loss of control in flight, much less frequent fuel exhaustion, and improvements in several other somewhat less common fatal accident scenarios.

Make-Model	Serial #
Cessna 172R	172B1201
Cessna 172S	172S10000
Cessna 182T	182B1298
Cessna T182T	T18208225
Cessna 206H	20608191
Cessna T206H	T20608439
Cirrus SR20	1337
Cirrus SR22	436
Columbia Aircraft LC41-550FG	41563
Columbia Aircraft LC42-550FG	42502
Diamond Aircraft DA-40	40.345
Diamond Aircraft DA-42	40.FC002
Cessna LC41-550FG	N/A
Lancair LC41-550FG	41001

Make-Model	Serial #
Lancair LC42-550FG	N/A
Mooney M20M	27-0324
Mooney M20R	29-0321
PA-28-161	2842201
PA-28-181	2843586
PA-28R-201	2844105
PA-32-301FT	3232014
PA-32-301XTC	3255014
PA-32R-301	3246216
PA-32R-301T	3257339
PA-46-350P	4636349
Raytheon A36	E-3535
Raytheon G36	E-3630

Figure 1. Make models in which all aircraft are now glass cockpit.

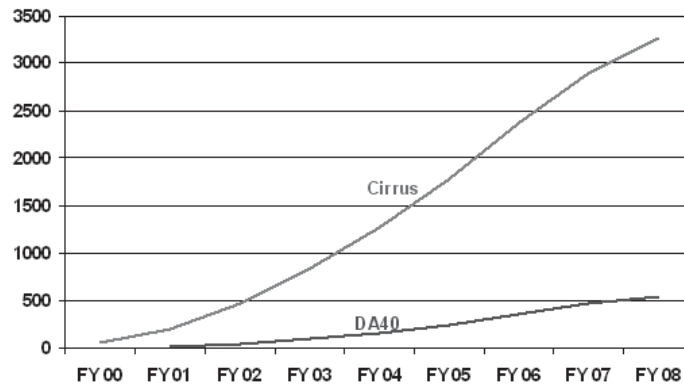

Data for FY 2008 estimated based on certificates as of June 30, 2008.

Figure 2. Cirrus SR20/22 and Diamond DA40 aircraft on U.S. registry with valid airworthiness certificates as of end of fiscal years (September 30).

When glass first began entering the small aircraft fleet, the equipment outlined above was optional. In 2003 and 2004, many make-model aircraft began incorporating glass cockpits in all aircraft. However, even if we accept a uniform definition of “glass,” we can not identify exactly how many glass-cockpit aircraft are in the fleet because we can not accurately identify the number of new aircraft that were delivered with the earlier optional equipment, nor the number of aircraft on each registry that has been retrofitted to various standards.

However, we can identify the number of aircraft, by make and model, on each national registry that was produced after the respective make-model was available only with glass. Figure 1 lists the most common airplanes that are now available only with glass and shows the serial number after which only glass was made available.

Light aircraft with glass cockpits have entered the fleet most rapidly in the U.S. and Australia, where the assuredly glass aircraft account for 3 percent and 2.7 percent of the fleet, respectively, as of May 2008. In Canada, these aircraft have entered the fleet a bit more slowly but at a still comparable level of 2 percent of the overall fleet, while penetration in the UK has reached just 0.8 percent of the fleet. However, retrofits and earlier, optional purchases of glass cockpits with new aircraft would at least double the penetration of “glass” in the four countries. Since new aircraft average more flight hours than older aircraft, small aircraft with glass cockpits already may account for 8 to 10 percent of all

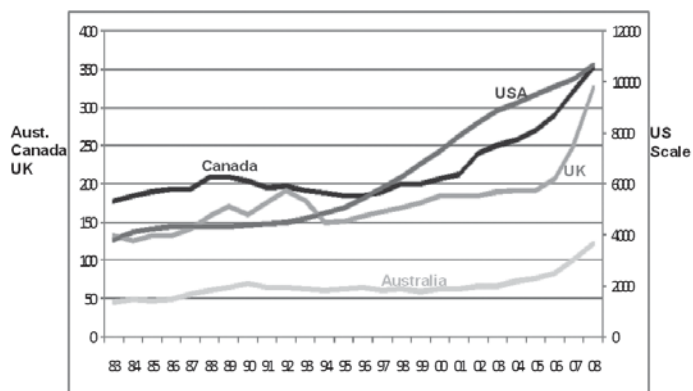

Figure 3. Business jets in service in four countries. All data as of June 30 of each year. (Source: Airclaims)

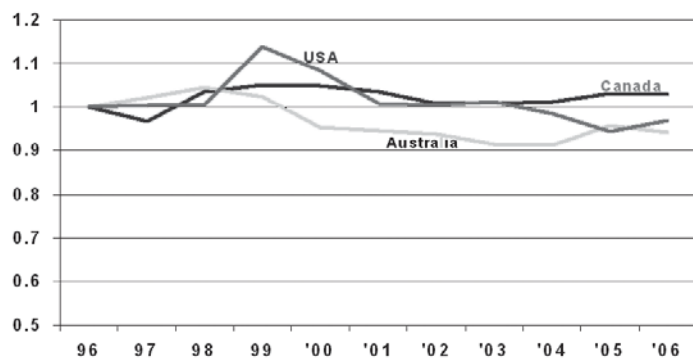

Figure 4. Trends in total GA hours, 1996–2006 in Australia, Canada, and USA.

flight hours in the U.S. and Australia. Given the rapid growth in business jets in all four countries, plus the penetration of new small aircraft, the total glass-cockpit fleet already accounts for nearly 15 percent of all GA flight hours in the U.S. and perhaps 12 percent in Australia, Canada, and the UK.

The Cirrus SR20/22 and the Diamond DA-40 illustrate just how rapidly TAA and glass-cockpit aircraft have entered the fleet in the United States. Based on data through June 2008, Figure 2 shows that, by the end of FY 2008 (September 30), the U.S. aircraft registry will have nearly 550 active DA40s and 3,300 active Cirrus SR20/SR22 aircraft. These two fleets alone will produce just more than 1 million flight hours in the U.S. in 2008.

### Business jets

The business jet fleet has doubled or tripled in the past 15 years in each of the four countries, as shown in Figure 3. Though the size of the markets varies, Figure 1 shows comparable trend lines among the four countries. From 1983 through 1994 or 1995, the business jet fleet in each country grew only slightly, if at all. Beginning in 1994 or 1995, the fleets in Canada, the UK, and the U.S. began rapid and sustained growth that has not yet abated. The figure indicates that the rapid growth did not begin in Australia for several years after that, but the pace since then has replicated the growth in the other three countries.

Several factors explain this sustained and rapid growth in the business jet fleet. First was the sustained economic boom that began in the early to mid-1990s, which made business jets more affordable and more attractive to many companies. The second

factor is related to the fallout from 9/11. Security, congestion, higher load factors, and increased price have combined to make “premium travelers” seek alternatives to the airlines. Premium travelers (those who buy first-class, business-class, or full-fare coach tickets) are the one group that can generate meaningful profits, but they have shifted in large numbers to business or corporate aircraft, fractional ownership, air taxis, or to flying their own aircraft. *Aviation Daily* reports that the number of trips by premium travelers who used other segments of aviation equaled 18 percent of all premium tickets sold by U.S. carriers in 2000. By 2008 that figure was equal to 41 percent.

### Changes in the mix of who is flying in GA

Figure 4 shows trends in total GA flight hours in Australia, Canada and the U.S. from 1996 through 2006. Each country reports data slightly differently and each defines terms somewhat differently, which makes precise comparisons impossible. For example, Canada reports hours for private, corporate, and “other” flight as a single figure. Australia reports private and business flight hours separately, and the U.S. reports “personal,” “business,” and “corporate” flight as three distinct activities. Australia and the U.S. also report several other separate activities that may be recorded as “business” flight elsewhere.

Generally, since 1999, trend lines in all three countries are modestly negative, but the aggregate trend lines obscure significant changes within the distribution of flight activity. As Figure 5 shows, “private and corporate” flight in Canada decreased by one-fourth in the decade through 2006. Similarly, as of 2006, private flight in Australia had decreased by 16 percent from its peak in 2002 and personal flight in the U.S. had decreased 20 percent from its peak in 2000. Agricultural flight also has fallen sharply in the two countries that report it separately, and instructional or training hours have decreased from their peaks. Since data on training hours include training for various upgrades of existing pilot certificates, the data understate the decrease in training for new pilots.

Cost explains much of the decreases in personal flight or instructional flight. A person with no flight experience can expect to spend a total of about \$10,000 to obtain a private pilot’s license in the U.S. In addition, the cost of fuel has soared, and many regions continue to witness higher landing fees, reductions in available airspace, and new security restrictions. Then add the factor of higher prices for certified aircraft, which start around US\$300,000 for a well-equipped airplane and can easily approach or exceed US\$1 million. The bottom line is that the populations and fleets with the highest accident rates account for a steadily decreasing share of flight hours.

In contrast, given their prices, glass-cockpit and other technologically advanced aircraft are unlikely to sit on the ramp for weeks at a time. Instead, these aircraft are being purchased primarily for business or air taxi operations, and by private pilots who fly frequently for personal reasons. The hours associated with these aircraft and with the rapid growth in business jets will replace much of the lost activity among the more recreational pilots and in the higher-risk activities such as amateur aerobatics, casual flight in local practice areas, etc.

The result is that aggregate accident rates should improve simply as a function of GA’s demographics. Finally, add the improvements offered by glass-cockpit aircraft and other technologically



AUSTRALIA	1996	1997	1998	1999	2000	2001	2002	2003	2004	2005	2006
Private	261.6	266.7	263	275.9	248.5	261.7	270.2	239.7	247.2	239.2	227.2
Business	182.8	176	163.8	153.3	138.3	144.9	142.2	143.4	143	149.1	144.1
Training	444.9	449.5	478.5	448.8	413.8	406.2	410.8	420.3	352.2	415.8	424
Agriculture	117.4	128.4	139.2	126.3	115	106.7	70.8	69.7	86.5	95	61.7
Aerial work	285.7	307.4	312.4	306.6	296.9	294.2	327.1	322.5	312.4	318.8	337.9
Test & ferry	26.2	27.8	26.8	26.8	27.9	23.2	20.9	21.3	22.3	22.3	21.7
Charter	480.4	483.7	494.6	504.6	476.7	466	445.7	429.2	481.4	482.6	478.4
Total	1,799.0	1,839.3	1,877.9	1,842.2	1,714.8	1,702.9	1,687.7	1,645.9	1,646.0	1,722.8	1,695.0

CANADA	1996	1997	1998	1999	2000	2001	2002	2003	2004	2005	2006
Air Taxi	803	732	805	825	792	754	683	651	660	697	N/A
Aerial Work	137	141	173	197	219	242	262	262	313	332	N/A
State	146	142	174	198	220	240	258	307	285	295	N/A
Corp, Private/Other	587	553	630	629	612	556	496	463	448	467	N/A
Helicopters	574	543	610	609	604	604	578	590	586	591	N/A
Total	4,243	4,108	4,390	4,455	4,447	4,396	4,279	4,276	4,286	4,377	N/A

USA	1996	1997	1998	1999	2000	2001	2002	2003	2004	2005	2006
Personal	9,037	9,844	9,781	11,072	11,477	11,266	11,025	11,251	10,239	9,266	9,141
Instruction	4,759	4,956	3,961	5,795	5,050	4,307	4,182	4,393	4,035	3,635	4,322
Aerial Application	1,713	1,562	1,306	1,408	1,318	1,038	1,182	1,099	1,142	1,031	946
Corporate	2,898	2,878	3,213	3,535	3,341	2,857	3,275	3,227	2,949	3,072	3,114
Business	3,259	3,006	3,523	3,602	3,588	3,579	3,287	3,377	3,249	3,244	3,234
Observation	1,057	1,261	812	1,244	1,545	1,442	1,366	1,262	1,467	1,265	1,197
Other	2,354	2,293	2,921	2,590	1,519	1,141	1,228	1,388	1,917	1,655	2,009
Air Taxi	3,500	3,100	3,210	3,260	3,160	3,400	3,160	2,927	3,238	3,815	3,742
Total	28,577	28,700	28,727	32,506	30,988	28,830	28,695	28,924	28,126	26,983	27,706

Figure 5. GA flight hours (000) by selected flight activities in three countries.

advanced aircraft, and the net effects should be substantial on GA accident rates, as discussed in detail, below.

### Net effects of glass cockpits on fatal accident rates

TAA and glass-cockpit aircraft will improve safety and substantially so. Yet, despite the sharp improvement in navigation capabilities and situational awareness that the new aircraft offer, several factors suggest that the improvement will be achieved incrementally rather than in a one-off safety revolution.

### Factors that will restrict or delay the safety benefits

Though some of the preceding data have shown that these aircraft are entering the fleet rapidly, they will require time before they account for anything that approaches a majority of GA hours. More importantly, these aircraft have their own flight characteristics and will require some new skills and at least a temporary learning curve. They also have their limits. As in the air carrier world, the new equipment will help properly trained and prudent pilots to avoid trouble or to respond safely if they get into trouble, but it will not save us from fundamentally bad decisions.

For example, an AOPA analysis of TAA accidents finds that TAA aircraft have a fairly high number of landing accidents. AOPA explained this by noting that many of the high-performance TAA aircraft do not slow down like some other aircraft. AOPA also noted that TAA and glass aircraft are disproportionately represented in weather accidents. A review of fatal accidents in glass-cockpit aircraft in the U.S. undertaken for this paper also found a surprising frequency of controlled flight into high terrain (CFIT) and confirmed AOPA's findings.

Some of this simply reflects the demographics of who buys TAA glass aircraft, namely operators who fly for transport purposes and who are a bit more likely to operate in IMC. However, some pilots have exposed themselves to higher-risk situations, perhaps in the expectation that the technology would ensure their safety.

The U.S. has had 24 fatal accidents in aircraft that clearly were delivered with glass cockpits. Of the 24 fatal accidents, 4 involved landing long and fast and/or going around. Ten of the 24 oc-

curred in instrument meteorological conditions (IMC), and 2 involved known icing in visual conditions. Several also involved night VFR flight. Below are some brief examples.

- Two pilots, one low-time and the other very experienced, took off VFR at night from mountainous locations; both struck high terrain on climbout, while another CFIT accident involved night VFR.
- Two accidents involved VFR into known icing, and three involved IFR into known icing (none of the five aircraft was certified for flight into known icing).
- A pilot, who landed short, IFR at night, advised ATC that he was having "trouble" with his coupled approach, while another pilot landed short in night IMC after trying to

divert to several different airports.

- Several others included loss of control in night IMC.
- One pilot lost control while flying low on a wildlife observation flight (high-performance aircraft probably are not the right fleet for such activity), and another pilot flying VFR at night flew wings level into a lake.

As some of these examples imply, having a system available is not the same as using that system. Several CFIT accidents occurred despite terrain displays and warning systems, presumably because a different page was displayed on the MFD. Similarly, several weather accidents occurred despite having weather radar or XM weather. Not unlike other pilots who fail to get weather updates in flight, the airplane will not give us weather unless we ask for it.

In addition, glass-cockpit aircraft require that we program the equipment correctly so that the airplane can perform its precision flying and take us where we expect to go. Finally, even when the aircraft is properly programmed, overreliance on the technology can invite trouble when ATC starts barking unexpected and un-programmed instructions at a pilot in busy airspace. In short, glass still requires good, basic flying skills.

The remaining limitations on the positive impacts of glass and other TAA aircraft will come from various sectors of GA that simply will not be influenced by the new technology, or at least not significantly so. As Figure 5 shows, activity in several sectors of GA is decreasing. Nevertheless, sectors like agriculture, other aerial work, aerial observation, air tours, offshore energy support, medical helicopter services, and others will continue to account for a substantial share of total flight hours. For the most part, the technology associated with the new fleet will have little to no effects on those activities. The technology also will have only limited effect on those accidents related to abrupt failures of systems or components in flight. This, in turn, will minimize the impact that the new technology will have on the aggregate measures of safety that most governments report, such as fatal accident rates.

Yet, despite these honest caveats and the examples outlined above, the new equipment already has helped to reduce fatal

	Australia	Canada	UK
All CFIT	46	64	63
Emergencies	8	38	19
Loss of Control in Flight	40	42	46
Loss of Control Maneuvering	4	4	4
Loss of Control on T/O & Climbout	6	5	3
Midair Collisions	50	67	50
Undershoot-Overshoot	23	14	20
TOTAL	18	23	20
(N Accidents Reviewed)	158	144	129

**Figure 6. Percent reduction in selected accident types in three countries with glass-cockpit aircraft.**

	2003	2004	2005	2006	2007	2008
CFIT	51	53	45	46	28	20
Loss of Control (LOC) in Flight	73	70	63	52	66	47
LOC During Emergency	12	14	16	19	21	12
LOC Maneuvering	55	48	57	42	57	44
LOC T/O - Climbout	64	59	79	48	51	56
Undershoot-Overshoot	77	67	69	59	47	41

**Figure 7. Selected classes of fatal accidents in the U.S. by fiscal year 2008 based on data through May 31 (8 months).**

accident rates and can be expected to do so at an accelerating pace as we work through the learning curve. The anticipated positive influences are outlined below.

### Estimated reductions in fatal accidents

The effects of TAA and glass-cockpit aircraft were estimated by analyzing 444 fatal airplane and helicopter accidents from 1998 through 2007 in Australia, Canada, and the UK, plus 2,126 fatal accidents in the United States from October 2001 (FY 2002) through May 31, 2008. The analysis tested each fatal accident against the key characteristics of glass-cockpit aircraft, as identified above, (e.g., PFD, MFD, autopilot, moving map, electronic charts, fuel-distance radius, etc.). The effects estimated here are intentionally cautious and reflect the likelihood of the new technology being used in a particular flight regime (such as agricultural work) or the technology's ability to affect the causes of an accident (such as fuel management versus pilot incapacitation).

The strongest effect will occur in fuel management. This has been a persistent source of a small percentage of fatal accidents. Excluding other fuel issues, like fuel contamination because of failure to secure fuel caps, straightforward fuel starvation accounted for 4.4 percent of fatal accidents in Australia from 1996 to 2006, 3.5 percent in Canada, and 6.4 percent in the U.S. Only the UK data show fuel exhaustion to be a rare causal factor in fatal GA accidents. With the fuel-management tools available on new aircraft, none of the four countries reviewed has yet to have an accident, fatal or non-fatal, involving fuel starvation. Though human creativity may enable some pilots in the future to accomplish the task, these aircraft should nearly eliminate fuel exhaustion and fuel mismanagement as a risk. The other areas of strong impact will be in CFIT, midair collisions, loss of control in flight, and approach-and-landing accidents. Many of these reductions were related to assumptions about

onboard weather information, traffic alert systems, autopilots, and moving maps.

In contrast, weather information was found to have limited positive effect on weather-related accidents that occur during take-off and climbout. The primary explanation is that poor weather during that stage of flight was rarely a surprise. Good onboard weather information in many such accidents in all four countries would merely have provided one more source of information to be ignored.

The degree to which these improvements will affect accident rates in each country depends on its current mix of accidents. For example, though glass-cockpits and other TAA aircraft may essentially eliminate fuel exhaustion, this will have little effect on the UK's accident rate because that has not been a significant issue in fatal accidents in the UK. Similarly, a significant reduction in high-

terrain CFIT accidents will have a relatively modest net effect in Australia, where mountainous terrain is less pervasive than in other regions. As a result, a higher proportion of Australia's CFIT accidents involve low-level flight and low terrain, where terrain warning systems will be less effective. Australia also has had an unusually high number of wire strikes

among its fatal accidents, and those events will not be easily influenced by the new technology. In contrast, CFIT is a major issue in Canada and the United States, where three major, north-south mountain chains traverse the continent. CFIT in the UK falls somewhere between the experience in North America and Australia.

As Figure 6 illustrates, the new aircraft should have comparable effects on accident reduction across the different countries in several accident categories. The total estimated reduction reflects differences in accident mixes across the different countries. Note that the estimates implicitly reflect the distribution of accident types among the various categories of flight activity, including agriculture, low-level observation, etc.

Due to the size of its system, recent data from the U.S. provide some statistically defensible evidence of how these factors might influence overall fatal accident numbers in the near term. Figure 7 shows recent U.S. trends since FY 2003 in several categories of accidents that typically have severe outcomes. As the figure shows, fatal CFIT accidents have decreased 61 percent since 2003, while fatal undershoots-overshoots have decreased 37 percent. Fatal loss-of-control-in-flight accidents has decreased 36 percent. As with anticipated improvements found in the other three countries shown in Figure 6, decreases in fatal loss-of-control accidents while maneuvering or during takeoff and climbout are not as dramatic, but they are meaningful. Only fatal loss-of-control accidents during emergencies show no change, consistent again with findings shown in Figure 6.

Overall, fatal accidents in the U.S. are expected to be about 30 percent lower in FY 2008 than in FY 2003. A small decrease in flight hours since 2003 can explain perhaps 5 percent of the decrease. The major factors appear to be those emphasized in this paper: the entry of TAA and glass-cockpit aircraft into the fleet, the growth of business jets in the fleet, and changes in the mixture of the purpose of flight. Changes in flight purpose probably have been the most significant factor in the decrease to date.

However, over the longer term, TAA and glass-cockpit aircraft, along with more business jets and new VLJs, should accelerate the improvement for the next several years.

### Conclusions

Glass-cockpit and other technologically advanced aircraft are beginning to enter the fleets in substantial numbers in all four countries reviewed in this paper. The pace of market entry varies, as does the continued and rapid growth in business jets, but those changes will continue. As a result, general aviation, including air taxis, is undergoing its first broadly based change in technology in several decades. These changes will bring significant and lasting improvements in fatal accident rates in all four countries, though perhaps at different paces.

Improvements will not occur as an abrupt revolution in rates. Several factors preclude that from happening, such as the time required for greater penetration of the fleet, a learning curve as

some pilots move into newer aircraft and the continued significance of certain activity types that will not be influenced much by the new fleet. Instead, improvements will continue to be incremental, but the improvements will be persistent and increasingly substantial over time. ♦

### Endnotes

<sup>1</sup> "GA" often is used in a manner that suggests a well-defined, single class of activity. In practice, "GA" essentially means "other than airlines," which captures a host of very different activities in different fleets and different operating environments. Yet the four countries examined in this paper define GA slightly differently, and each country computes and publishes accident data that capture slightly different fleets and activities.

For the purposes of this paper, "general aviation" excludes scheduled passenger service and non-scheduled passenger or cargo service in air transport aircraft. Also, to reflect differences in the way each country organizes its data, this paper defines GA to exclude microlights or ultralights, sailplanes, and lighter-than-air ships. "GA" is used here to capture all other flight activity, including helicopters, air taxis, personal flight, business flight, corporate aviation, for-hire sightseeing or air tours, etc.



# Bringing the Worldwide Helicopter Accident Rate Down by 80%

By Jack Drake, Helicopter Association International, USA



*Jack Drake is currently an independent aviation safety consultant and co-chair of the International Helicopter Safety Team's Accident Analysis Group. He is a former director of safety for Helicopter Association International and director of operations safety for America West Airlines. Before that, he was an investigator and manager at the National Transportation Safety Board for 26 years; and he was a pilot, flight instructor, and safety officer in the U.S. Navy. Jack has been a member of ISASI since 1977.*

This presentation was motivated by a personal desire to spread the word about an exciting new approach to accident prevention that has particular applicability to air safety investigators, safety researchers, and aviation safety agencies. Traditionally, if we were participants in a government-led aircraft accident investigation, the objectives would be to determine the factors that led to the accident, to define the “probable cause” (or causes), and to initiate corrective actions to prevent future accidents. The safety recommendations that followed would usually advocate regulatory change to require sometimes narrowly defined corrective actions. This methodology is frequently addressed as the reactive approach or “preventing the last accident.”

That's the way fatal air carrier accidents have been addressed in many countries over the past 40 years, and despite lots of criticism, the approach has helped to bring the air carrier accident rate down substantially. Unfortunately, general aviation accidents, especially those that did not involve mechanical failures of critical components, although much more numerous, usually do not result in the issuance of safety recommendations—either because the accidents were not investigated to sufficient depth to support recommendations or because regulatory change could not be justified. Studies of similar accidents are infrequently conducted and we continue to experience accidents just like we did before.

A more proactive approach and a desire to improve the worldwide helicopter accident rate, which was perceived to be unacceptably high and negatively influencing the safety image of all helicopter operations, led to the formation of the International Helicopter Safety Team (IHST) in late 2005 and its commitment to reduce the worldwide helicopter accident rate by 80% in 10 years. It was recognized by the government-industry partnership that constituted the IHST that its goal could not be achieved by looking at general aviation and helicopter accidents and investigative reports in the same way.

The taskforce formed to address and try to correct the problems contributing to the helicopter accident rate was led initially by the U.S. Federal Aviation Administration (FAA), airframe and engine original equipment manufacturers (OEMs) in the United States, and by operators and associations, such as the Helicopter

Association International (HAI), who represented U.S. operators. As the initiative has grown internationally, other countries have stepped up or expressed interest in using or adapting the model developed in the U.S. by the IHST.

At the writing of this paper, the European Aviation Safety Agency (EASA) and Canada are continuing the initiative by examining more closely their regional accidents while refining the IHST methodology to optimize the ability to identify corrective actions there. Several other countries and regions have begun to organize similar teams to determine how the process can reduce accident risk elsewhere. The methodology of the IHST was adapted from the U.S. Commercial Aviation Safety Team (CAST), which set out to substantially reduce worldwide commercial airline fatal accidents by addressing proactively common accident causes. Many of us have seen some of the by-products that addressed controlled flight into the ground, approach and landing accidents, and uncontained engine failures. The IHST set a similar but higher goal—to reduce the rate of *all* helicopter accidents, worldwide, by 80%—and progress is already being made.

## Measuring our progress

While it must be admitted that the 80% goal was borrowed from CAST, the expectation from the beginning was that the goal could be achieved—because of the early success of CAST in bringing down the fatal air carrier accident rate and a belief that the helicopter community could be convinced that a systematic approach to helicopter safety was both overdue and needed. The IHST hoped for and saw an early reduction in the U.S. helicopter accident count and rate (in 2006) that was apparently the result of enthusiasm for the program and improved industrywide safety awareness. While that improvement was gratifying, it also became apparent that we didn't actually know the U.S. and worldwide helicopter accident rates because we didn't have a good handle on the denominator in the equation, helicopter operating hours. Measuring future helicopter accident rates (and our progress) would require more accurate measures of helicopter flight hours, which had traditionally been estimated based on limited operator surveys and were notoriously inaccurate. FAA flight hour estimates were used by the helicopter industry to calculate accident rates. The IHST decided it would start its program using industry-accepted accident rate data from the years immediately preceding the start of its programs, but it also committed to initiate an effort to improve the flight hour measurement that was critical to accurate accident rate calculations. Bell Helicopter has taken the lead on this and is collecting flight hour data for all helicopter models worldwide. The process will use data points from aircraft sales, public records of aircraft registrations, service difficulty reporting, maintenance data, and other sources. The data will allow us to calculate accident rates more accurately in the

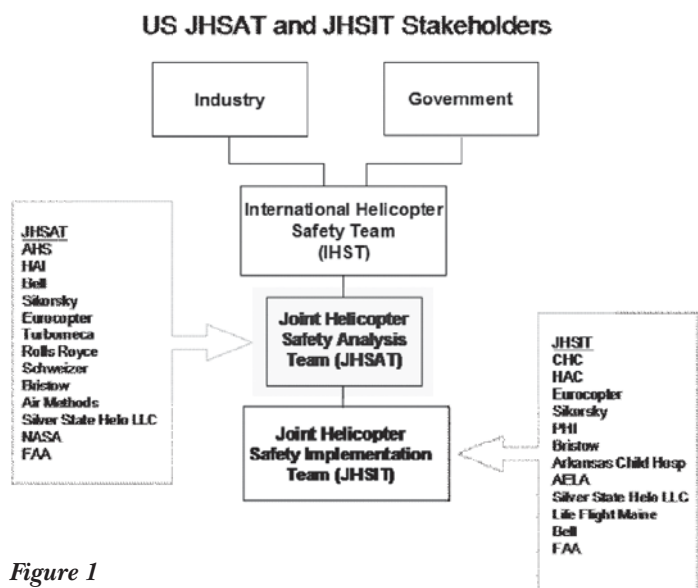

Figure 1

future and (we believe) will allow us to show that flight hours are higher than previously estimated and accident rates are lower than previously indicated by industry data.

### The IHST process

The process whereby the IHST is analyzing accident data to achieve a higher safety goal is illustrated by the following charts and described briefly here. First (Figure 1), IHST is a government-industry partnership that seeks to bring about safety change without increasing regulation. It is not a U.S. program (although it was dominated by U.S. participants in its first 2 years). It is an international safety program that hopes to grow to a worldwide effort to reduce the risk of helicopter accidents worldwide. Further, there is no reason its principles couldn't be applied proactively to all segments of aviation and to other industries. Very simply, it uses the combined talents represented by regulators, manufacturers, operators, and other safety specialists to examine accident reports to identify the events that contributed to accident causes (root cause analysis) and to find interventions to address each of those factors. Recommendations that would come from the analysis process would be based on those interventions that are considered most feasible and economically acceptable to a cost-conscious industry. The analysis function and production of recommended interventions is the function of the IHST's Joint Helicopter Safety Analysis Team (JHSAT). The vetting, prioritizing, and selling of the best of the recommendations is the work of the IHST's Joint Helicopter Safety Implementation Team (JHSIT). The first chart illustrates the IHST organization and the initial makeup of the U.S. JHSAT and JHSIT teams. Not surprisingly, the roles of the U.S. teams have evolved, partly because of the expansion of the process internationally and partly because of the evolution of the tasking. One noteworthy change is that the U.S. JHSAT has gradually assumed a regional role in a coordinated effort with other state or regional JHSATs while it has also refined its accident analysis process.

The second chart (Figure 2) illustrates the analytical process used by the JHSAT. The charter of the organization established the ground rules, and the CAST-based process assured that the result would be data-based, objective, and acceptable to the majority of the team. The team was selected from applicants with

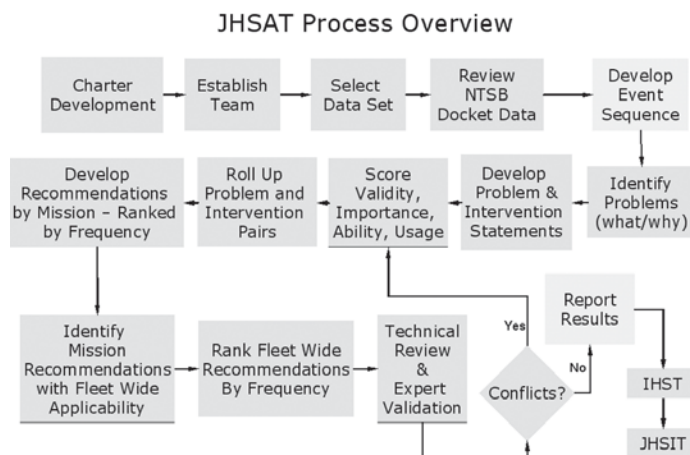

Figure 2

accident investigation, safety research, and proactive aviation safety experience, who also represented a cross-section of the industry. There was a deliberate effort to achieve balance between members who would represent regulators, manufacturers, and operators, and to bring to bear real world experience. It was necessary to select a dataset that was several years old because it takes a few years before entire calendar year accident sets are completed by investigation authorities and recent accidents might still be in litigation (precluding some members from participating in the JHSAT group analyses). Thus, the U.S. JHSAT decided to start (in early 2006) with the U.S. National Transportation Safety Board (NTSB) calendar year 2000 accident dataset, which consisted of 197 accident reports and about 4,000 docket items (reports, statements, photos, and supporting documents).

Having established what we would examine, we developed a methodology that included development of standardized problem statements (SPSs) corresponding to the events or links in the safety chain that were considered to have contributed to the causes of the accidents or our ability to define those causes (missing data). Having defined the problems, we developed a set of corresponding interventions that were thought to be appropriate mitigations for the SPSs. When data were insufficient to define exactly why an event occurred, we still attempted, based on our collective experience, to determine how the problem or accident might have been prevented. We did not rely on "probable cause" determinations and typically arrived at more problem statements and interventions than would be found in the conclusions of the NTSB reports.

The identified SPSs and interventions were "scored" based on how well the group felt the SPS or linked intervention defined the problem or would eliminate it in a real-world setting. In the roll-up of the data, there were about 1,200 SPS-intervention pairs. Those interventions that became the recommendations of the JHSAT (numbering about 135) were those that appeared most frequently in the roll-up of all of the data, as the frequency of occurrences was found to outweigh the qualitative analysis of individual interventions.

The U.S. JHSAT report summarizing its first year of accident data analysis and recommendations is available to the public by free download from the IHST website (<http://ihst.org/images/stories/usJHSAT2000Report.pdf>). It is interesting to note that while the report discusses the accidents from the perspective of 15 different mission categories, the majority of the safety issues and

intervention recommendations were substantially the same across mission categories. Most of the problems defined were operational, and most of the interventions addressed better risk management, operational oversight by operators, and training. The presentation of the JHSAT report to the IHST, in September 2007, officially transferred the result of the first year of JHSAT effort to the JHSIT, which was tasked with deciding which recommendations to prioritize and how they should be implemented. That work is on-going, even as the JHSAT is now concluding its second year of accident data analysis.

### We know more than we know!

An in-depth review of a large number of accident reports and their probable causes reveals many things, but not all we'd like to know—particularly if our task is to determine responsibility for the accident (our tasking was to look for prevention opportunities, not for causes). We'd like to know more about the pilot's training and decision-making, whether undocumented human factors were involved, the exact sequence of events, what the pilot saw and what actions were taken, how the aircraft systems responded, and how company standards (or lack thereof) and pressures affected crew performance on the accident flight. Without detailed documentation of these things and digital data from the aircraft, many of those questions remain unresolved in too many cases. However, the accident reports, especially when examined in the context of reports of similar events, do reveal a great deal about how such accidents might have been prevented. We can read between the lines to some extent, especially when we've seen the same set of circumstances described in a variety of reports. The JHSAT examination, even of investigation reports that were lacking, found lots of fertile ground for interrupting the causal chain with proactive action to reduce the accident frequency and rate. The following case studies are offered to illustrate the process and the potential value of the JHSAT process and data

#### Case Study #1: Offshore, Part 135 Cargo

The helicopter went missing and presumably crashed on a night overwater flight in support of oil industry operations over the Gulf of Mexico (GOM) in deteriorating weather. The accident flight was one of several that day for the 61 year-old pilot, who transported personnel and cargo between shore bases and oil rigs, and from rig to rig. The pilot's duty day began at 0800 and was drawing to a close 13.5 hours later, after about 7 hours of flight time, as he tried unsuccessfully to find the oil rig that was his final destination. Meteorological data indicated that the flight most likely encountered adverse weather (high winds, low ceilings, rain, and reduced visibility) in darkness. Although he was highly experienced in VFR operations, the pilot was not IFR-rated and the aircraft was not equipped for instrument flight. The pilot relied on a GPS receiver, a telephone, and DR navigation to find his destination, as there was no FAA communications or radar flight-following available near the presumed crash site. Analysis showed that the aircraft was about 25 miles from its destination and well off course when the pilot last spoke to a company dispatcher. The aircraft never arrived and the wreckage was not found. As with all the other cases examined, the aircraft was not, nor was it required to be, equipped with cockpit or digital flight data recorders. Nonetheless, the NTSB report was rich with information that provided an understanding of the circumstances

that may have led to the accident, and the JHSAT elected to consider this information as it examined how the accident might have been prevented. Probable cause: Undetermined. NTSB recommendations: None.

#### Problem statements

- Pilot experience lead to inadequate planning with regard to weather.
- IFR system incompatible with mission.
- Management policies/oversight inadequate.
- Management disregard of human performance factors (i.e., duty/flight time, fatigue).
- Pilot disregarded cues that should have led to termination of course of action.
- Darkness, fog, and rain.
- Data/information not available to investigators.

#### Proposed interventions

- Company risk assessment/management program.
- FAA installation of ADS-B in GOM to facilitate IFR operations in adverse weather and at night.
- Establish company SOP that disallows flying in adverse weather at night except under IFR.
- Company SOP to eliminate onerous flight schedules and reduce risk of fatigued pilots.
- Incorporate non-punitive fatigue call-in protocol.
- Company risk assessment/management program.
- Cockpit recording device with underwater locator.

#### Case Study #2: EMS Positioning Flight

“Fire-Radio Dispatch” directed the launch of an EMS helicopter to an LZ on a residential city street at night, although the LZ was only a few minutes away and an ambulance was already on scene. Patient transport was intended to end at a hospital in another city. The launch decision by a non-aviation dispatcher was not questioned by the pilot/operator. Operator guidance (to ground emergency response crews) had previously established minimum LZ requirements, but a non-conforming LZ was selected and was accepted by the pilot. The pilot's high/low recon did not detect obstructing wires, and ground personnel incorrectly advised the pilot that there were no wires. Ground personnel did not adequately protect the LZ from approaching automobile traffic, which necessitated a go-around on final approach. The approach was not stabilized—the pilot carried insufficient power to clear obstructing wires—necessitating a controlled crash under the wires. The pilot had only 28 hours in make/model. Probable cause: Pilot failed to detect the presence of the wires and his misjudgment of clearance from the ground during the evasive maneuver. NTSB recommendations: None.

#### Problem statements

- Improper launch decision by non-aviation dispatch/communications center.
- Customer pressure to complete mission.
- Flight crew decision-making inadequate.
- Management policies/oversight inadequate.
- Improper landing site selection by ground emergency personnel.
- Pilot unaware of obstructing wires near the LZ.



- Evasive maneuver required—pilot inexperienced in make/model.

### Proposed interventions

- Mission specific (EMS) risk assessment training for dispatch/communications center personnel.
- Assertiveness/AMRM training for flight crew.
- Mission specific (EMS) operational risk assessment program.
- Establish/assert operational control/oversight by operator.
- Reinforce the purpose and importance of landing site recon.
- Establish pre-approved landing sites for EMS activities.
- Risk assessment/training for LZ personnel.
- Risk assessment program that addresses night LZ operations.
- Establish EMS mission specific operational risk assessment standards/controls.

### Case Study #3: Returning from Electronic News Gathering (ENG) Flight

Two ENG aircraft were flying several hundred feet from one another when one pilot radioed the other, “Hey, watch this.” The pilot subsequently lost control and crashed; there was a post-crash fire and both occupants were killed. The investigation revealed that the accident pilot had a history of aggressive flying and risk taking, and he had a criminal record. Probable cause: The pilot’s decision to perform an abrupt low-altitude aerobatic maneuver. NTSB recommendations: None.

### Problem statements

- Improper pilot decision-making and actions.
- Pilot disregarded rules and SOPs.
- Inadequate company SOP and operational oversight.
- Inadequate crew hiring/screening criteria.
- Absence of threat-free safety event reporting system.
- Data unavailable to analyze the LOC maneuver.
- Crash-resistant fuel system had been removed.

### Proposed interventions

- Establish an operator safety/risk management program.
- Develop hiring/screening criteria for pilot applicants.
- Conduct procedural intentional non-compliance (PINC) training.
- Implement a non-punitive safety event reporting system.
- Use crash-resistant fuel systems (when available).
- Install cockpit data recording devices.
- Include helicopter data in PRIA (Pilot Records Improvement Act).

### Roll-up of U.S. JHSAT fleetwide recommendations

The proposed interventions in the case studies above illustrate the kinds of safety recommendations being considered by the IHST. Together they demonstrate there are many ways of preventing the same or similar accidents. The roll-up of the similar interventions sometimes resulted in combining, rewording, or dropping some potential recommendations when others seemed more viable. These case studies and the roll-up of the intervention recommendations show that there is greater potential for prevention based on the analyses of general aviation or helicopter accident reports than we have tapped in the past. While the resultant recommendations addressed mission groups separately, ISASI members may

be more interested in the kind of data-based recommendations that were proposed across mission groups (the fleetwide recommendations). Some of these are summarized below.

- Develop and use a formalized System Management Safety (SMS) to risk management to improve individual and organizational decision-making. Establish and use non-punitive safety event reporting systems to address employee safety concerns.
- Identify and manage risks associated with mission, low/slow and other higher risk maneuvers, and flight in close proximity to obstacles.
- Promote increased use of simulators, training aids, and training devices to reduce training risk and improve training and aeronautical decision-making (ADM) with regard to autorotation, loss of tail rotor effectiveness (LTE), aircraft performance capabilities and limitations, emergency procedures, inadvertent flight into instrument meteorological conditions (IIMC), make/model transitions, model-specific power and energy management, quick-stop maneuvers, landing practice on platforms and in unimproved areas, and pinnacle approaches.
- Provide extensive initial and recurrent emergency training as described in the *Rotorcraft Flying Handbook* and as outlined in the OEM rotorcraft flight manual to address autorotation, vortex ring state (settling with power), dynamic rollover, systems and equipment malfunctions, and loss of tail rotor effectiveness (LTE).
- Infrastructure: Ensure that crews are aware of adverse or deteriorating weather conditions by expanding availability of weather data needed for preflight planning and for inflight decision-making. Improve the Automated Weather Observing System (AWOS) infrastructure and other weather reporting sources to provide greater access to weather information. Share weather information, both reporting and receiving, through PIREP, the helicopter EMS (HEMS) weather tool, and other systems.
- Companies operating in the same local areas should formalize agreements to share weather data, especially when weather considerations result in refusing to accept or canceling flight operations.
- Improve maintenance by better integration of quality assurance systems and ensured adherence to instructions for continued airworthiness (ICA). Push strict adherence to ICA, including improved regulatory oversight of maintenance.
- Regulatory: Hold public-use military surplus helicopter maintenance to civil ICA (or equivalent) standards. Require that public-use operators comply with Part 91 operating rules. GSA: Take stronger action to minimize unapproved part use in public-use operations. Defense Reutilization and Marketing Services (DRMS)—develop an easily accessed database to identify released military surplus aircraft, engines, and critical parts.
- Regulatory: Make Pilot Records Improvement Act of 1996 (PRIA) information more readily available to employers for background checks by helicopter operators. Expand PRIA to include helicopter pilots and FAA disciplinary actions and make this data available for aviation employer background checks.
- Implementation of Health and Usage Monitoring Systems (HUMS) or Engine Monitoring Systems (EMS) capability for early detection of impending failure. Regulatory: Provide regulatory flexibility for installation of (HUMS/EMS) data recording systems.
- Improve crash survival by making greater use of available crash-resistant fuel systems and personal locator devices.
- Make greater use of helicopter terrain avoidance warning sys-

tems (HTAWS), obstacle proximity detection and protection equipment, radar altimeters, synthetic/enhanced vision systems (SVS/EVS), video recording systems (including rearward-facing cameras), and wire strike protection systems (WSPS) as applicable to aircraft mission.

- Encourage development and use of optional aircraft warning systems to include low rotor speed, low fuel quantity, and dynamic rollover alert systems.
- Install Health and Usage Monitoring Systems (HUMS) to detect impending mechanical failures, and utilize HOMP to monitor and provide oversight of flight operations.
- Install cockpit/data recording devices appropriate to mission and aircraft model—such as cockpit image/information recorders (CIR), (low cost) flight operations data recorders, GPS positional flight recorders, CVR/DFDR, and FOQA quick access recorders (QAR).

*Note: Although cockpit and flight data recorders were not installed on any of the 197 helicopters in the calendar year 2000 accident dataset, it is not farfetched in 2008 to be asking for their installation in many helicopter make/models. Sikorsky (as part of its Safety Enhancement Program) is currently installing CVR, FDR, and current generation TAWS as standard equipment in its commercial helicopter models and offering retrofit kits for its S-76 helicopters that were produced before 2005. Bristow/Air Logistics has installed low-cost flight operations data recorders in its Bell 206 and 407 aircraft and has recently received FAA approval for its flight operations quality assurance (FOQA) program, and ERA Helicopters was the first FAA-approved helicopter FOQA program. Without digital or video recording equipment installed, it is virtually impossible to accurately reconstruct the events leading to many helicopter accidents. With such recorders, it is possible to improve accident investigations and also to use digital data to reconstruct training or operational flights as a means of improving training and flight crew performance.*

### Accident investigating and reporting

The IHST sought improvement in accident investigation reporting so that reports by the investigating authority would be more useful for identifying root causes and implementing appropriate and responsive safety actions. To facilitate this, in June 2007 members of the JHSAT and JHSIT met with two NTSB members, the deputy director for regional operations, regional directors, and helicopter experts to discuss IHST findings and to offer suggestions, including a checklist (provided later) seeking documentation of the planning that preceded the accident flight, weather data available to the pilot, a description of any inflight emergency and how the pilot responded to it, a description of the size and complexity of company operations, the operator's program for managing risk and safety, the pertinent operator SOPs and operational oversight, the pilot's pertinent (mission) training and experience, company hiring criteria, the availability and usage of safety/mission equipment (including recording de-

vices), and other information that would aid the investigator in determining root causes of the accident. The NTSB subsequently responded that it would use the IHST suggestions to improve its accident investigations.

The IHST participants were very encouraged by the NTSB response and have high hopes that the result will allow root cause analysis and better safety recommendations in the future. If there is similar progress in getting more helicopters equipped with recording devices in the future, a quantum leap in credible accident investigation findings can be expected to follow.

### Safety is an attitude

To conclude, I'd like to refer to some anonymous ramblings (author unknown) that attempt to define what we are trying to do.

- Safety is not an activity to be engaged in only when one is being watched or supervised.
- Safety is not posters, slogans or rules; nor is it movies, meetings, investigations, or inspections.
- Safety is an attitude, a frame of mind.
- It is the awareness of one's environment and actions all day, every day.
- Safety is knowing what can injure or damage, knowing how to prevent the injury or damage, and acting to prevent it.

The International Helicopter Safety Team (IHST) takes the proactive attitude that anyone's helicopter accident belongs to all of us. Accidents affect our collective reputation as the providers of air transportation and the suppliers of air services that don't exist elsewhere. We don't need to accept accidents or a high industry accident rate, and it affects our profitability if we do so. The U.S. JHSAT attitude is that interventions can be identified and mitigated for all accidents, even when the exact causes are not known to the operator or the investigators. We don't have to sit back any longer and wait for a probable cause determination before we initiate risk reduction measures. We can use the data-based solutions derived by a team with broad helicopter safety expertise to reduce risk and the helicopter accident rate, and we can use that process to learn from other accidents. Other groups of helicopter safety experts representing other countries and regions are using similar processes to examine accident data from other parts of the world. All of us are working hard to deliver to you unbiased and data based solutions to prevent the problems that show up in the accident reports. But what is your attitude? Are you ready to use that data to bring about a more proactive safety culture, better operational oversight, better mission-specific operational training, better risk-based launch and inflight decision-making, and the installation of equipment that will reduce pilot workload, reduce accident risk, and better define why accidents occur? Those of us on the JHSAT hope you'll find our process useful and employ it elsewhere to improve accident investigations and make better use of the information contained in those reports. ♦

# SMS as an Investigation Tool

By Capt. John Gadzinski, Director of Safety, Southwest Airlines Pilots Association  
(ISASI Corporate Member)



**John Gadzinski** received his degree in 1986 from Boston University where he majored in music. He entered the U.S. Navy in 1986 and served until 1996 as a Naval aviator flying the F-14 Tomcat, A-4 Skyhawk, and also serving as a senior landing signals officer on the USS Eisenhower. John became a pilot for Southwest Airlines in 1996 and currently

flies the line as a B-737 captain. As a safety committee member for the Southwest Airlines Pilots' Association, John served on several accident and incident investigations, including the MDW overrun event. In 2006 John was selected to become safety chairman for SWAPA, and in 2008 John was selected as the director of safety for the Coalition of Airline Pilot Associations, where he currently serves.

**B**eyond the 45-degree shear lips of metal failure, the witness marks or the FDR review, there lays the bedrock of the system that gave rise to the conditions the accident you are investigating arose from. Beyond the cockpit or the radar screen, beyond the simulator or the training manuals, the tectonic forces that shaped the eventual outcome may have taken place slowly over time. The key is to uncover the resident safety pathogens that may have lied dormant, undiscovered until now, and to make sure the reasons for their seeming obscurity are not repeated in the future. One of your best tools is the knowledge of Safety Management Systems (SMSs).

It's a different way of mapping an investigation. Formal schooling will teach you to think linearly: Start at the accident and work backwards until you trace all the active and latent failures, errors, and oversights as if you were following a stream uphill. As your basic human factors textbook will point out, however, you have the benefit of hindsight; and the connections between events, conditions, and interactions can be clearly seen. The path taken to the accident site, however, may have been influenced by many factors that at the time were seemingly unrelated.

The Safety Management System is at its core a philosophy about how to look at safety. Virgil Moshansky's Inquiry report into the Dryden Accident and the Columbia Accident investigation board all pointed to organizational safety culture issues that made fertile fields for hazards to develop and lay dormant until conditions were just right for disaster. So what can the new investigators use to help gain a similar perspective, especially if they are not part of a presidential inquiry?

Since airplanes are machines and accidents involve machines, it makes sense for most of us to think in terms of machines. But what if, instead, we changed our perspective and look at the system the machines and people operated in as an organism? It's not hard to make the correlation between the basic concepts of SMS and the kind of people we see every day. SMS teaches us that there are basically three types of organizations: pathological, bureaucratic, and generative. There are systems that do what they can get away with without being caught (pathological), sys-

tems that do what they are comfortable with until there is an accident (bureaucratic), and systems that strive to learn and grow as a conscious act of continuous self-improvement (generative).

It's not hard to think of these concepts in human terms. At some point, most of us (usually at an early age) lived for the moment, merely hoping that nothing bad would become of it (pathological). We tend to spend our everyday lives in the "bureaucratic" model of safety. We do what is most comfortable and reasonable unless a sudden trauma (heart attack) makes us change our point of view and learn a lesson. Of course we all look up to the Lance Armstrongs or the Tiger Woods who physically and emotionally embody the concepts of continual learning, improvement, and a nonjudgmental approach to an acquisition of knowledge. In the end, we always hope that the organization we work for looks like such an organism, albeit from a business perspective. This is what is considered a "generative" organization.

We study examples of generative systems when we look at the cockpit of Al Haynes and United Flight 232 or the mission control of Apollo 13. We see how a group of individuals can come together as a team and adapt to the new, unplanned, and unforeseen conditions and how successful outcomes can result. From this lesson and many others, SMS teaches us that an organization's culture and philosophy on safety can often act as a precursor to its ability to *identify* and manage risk in complex systems. We also learn that it's not enough to simply catch violations and errors when someone is looking; the object of the game is to create a system that is continuously self-correcting and resilient. To do that, you need the four principles of a safety culture as spelled out is SMS. A safety culture is defined in terms of four basic attributes

- an informed culture,
- a just culture,
- a reporting culture, and
- a learning culture.

It sounds incredibly simple, but when measuring an organization's Safety Management System, there are really four basic questions an investigator must start with

1. Is there a written policy on safety?
2. Do people know about it?
3. Do the procedures employed reflect this policy?
4. Do the practices of the organizations follow the procedures?

At its heart, though, the above questions must be built on the central issue of what safety means to an organization? Is it a lack of bad consequences? Is it a reduction of risk? Does it even acknowledge that risks exist as a fundamental part of the business model? I will demonstrate how such a organizational culture can indeed set the basis for an accident.

One of the biggest challenges I had in a safety investigation took me a year to figure out. Here was the problem: A series of very detailed and scientific tests had been done on the issue of aircraft braking on winter contaminated runways. Out of many



years and millions of dollars, a final report had been drawn up and the data had been presented. The chart is probably familiar to most of you who have ever dealt with this problem and looks like this:

#### Braking Coefficients for all Aircraft vs CRFI

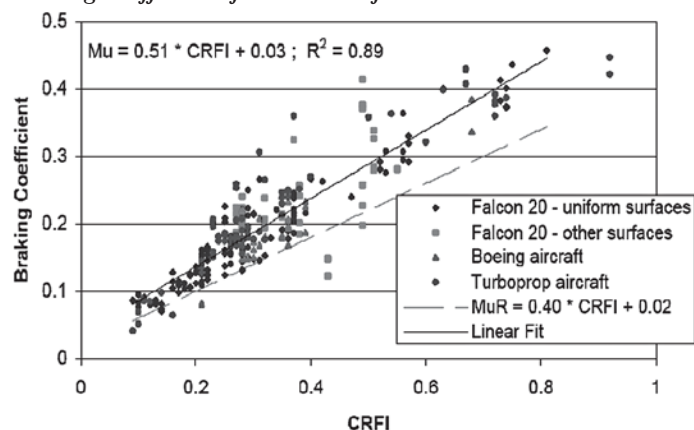

Source: Transport Canada Flight Research Laboratory Report LTR-FR-183, June 2002.

The chart above shows us a couple of things. One is that there is a wide range of data points with little resemblance to a linear correlation. If we statistically take the mean average, we can draw a correlation line (solid line). If we reduce the slope of that line, we capture the vast majority of data points above the new calculation shown (dashed line). The logic goes that if you wanted to make a correlation between the two values that captured more than 95% of the hard data, you could do it; but it wouldn't be 100% foolproof. There would still be some data points below the line that would represent a non-conservative relationship.

Sounds simple enough, but the problem was that there were two sets of very smart people living in two different countries that took this concept and came to very different conclusions.

The conclusion I drew was that it was this difference in cultures that contributed to the accident. In simple terms, one defined safety as an absence of liability to engineering uncertainty. The other defined safety as the reduction of risk to an acceptable level. The policy of the latter was clearly spelled out, communicated through advisory publications, and practiced operationally by pilots and airport personnel. Most importantly, they recognized that their system was not perfect and communicated when conditions would preclude any use of such a risk assessment tool.

The other culture was where the accident occurred and their method of risk management was articulated as follows:

*While it is not yet possible to calculate aircraft stopping distances from friction measurements, data have been shown to relate to aircraft stopping performance under certain conditions of pavement contamination, and are considered helpful by pilots' organizations."*

The questions are then asked, what is the safety policy this verbiage is supporting? What procedures are we to follow, how are we to know when to follow them, and what should our practices be?

The environment stated above was developed by people who had the best of intentions, training, and skills but their concept of risk was heavily influenced by the safety culture of their regula-

tory agency. That culture placed a high value on eliminating uncertainty and applied that to an area where *uncertainty was unavoidable*. The result was a lack of information on risk that blinded the crew to a dormant safety hazard and ended up in a well publicized runway overrun.

The hazard in this case was a type of contamination that can be hard to observe and even harder to predict regarding aircraft braking performance. Most commercial jet aircraft have a fully modulating antiskid system that protects the aircraft tires from failure to skidding and helps in directional control when landing on slippery runways. This works well when there is very little shear between whatever the tire is rolling on and the prepared pavement of the runway. Place a deformable surface between those two, however, and the effect is similar to total dynamic hydroplaning. Although the aircraft systems may be commanding 3,000 psi of hydraulics to the brakes, the antiskid systems may only be allowing 300 psi to the brake pads due to the increased slip ratio caused by the increase in horizontal shear between the tire and the pavement.

Added to this was a major safety variable. This condition is very hard to directly measure and communicate in a timely fashion. The runway condition for one jet could be different from the next landing 5 minutes later with no significant visual cues to the airport. The hazard described is known as "slush" and can form in a variety of ways from snow when local temperatures are within 3 degrees Celsius of freezing. When this happens, runway friction readings can be invalid, surface conditions may not visually change appreciably, and aircraft braking performance can deteriorate dramatically. There are no indications in the cockpit of how such braking system performance can be affected, very little visual cues to alert airport operators, and almost no high-speed indication to the pilot. This is because at normal landing speeds, the effect of wheel brakes can be completely masked by the aerodynamic decelerating forces acting on the aircraft. By the time the pilot notices, it is too late.

Conditions like these are often described as "pathogens" because while they may present a significant variable in safety, they only produce bad results when placed in the correct environment. In this case, all that was needed was a short runway and some faulty assumptions and any organization blind to this hazard could find itself unexpectedly thrust into a runway accident. But if the purpose of an investigation is to prevent such accidents, what must be done then is not only to look at the proximate cause associated with the event but more importantly understand why the organization was blind to such a pathogen to begin with. For that we go back to our knowledge of safety management.

SMS is at its very heart a collection of best practices institutionalized by an organization and its culture. As such, these practices define what poses the least legal liability for the organization. That is easy to say, but hard to practice. What happens when you put legal concerns ahead of safety practice? You get procedures that reflect a management of legal risk. How many times does a manual state "should" or "recommended"? Clearly someone who does something that's not recommended would be found at fault if the consequences for the judgment made turned out to be undesirable.

But what if the choices made by the person at the time made sense in the context of the situation? How was the policy on safety supported by the procedures written? How was the person in-

volved to understand it? If a flight director should be used but is not mandatory, is there ever a point where the risk of not using it becomes unacceptable? If this becomes a finding in your investigation, is the philosophy of risk management behind the written policy the root cause or is it the decisions made by the pilot?

Aviation is referred to sometimes as a “meta-system.” Humans interact with machines that interact with other humans and their machines in ways that are often difficult to predict. A system anomaly can cascade out of control in unexpected ways and result in an accident. As the reliability of our machines increases so do the consequences for system failure. The need for an ever-increasing level of risk management demands that we look at accidents and incidents beyond the bent metal and into the way the organization that supports them interacts, learns, and continually changes itself to constantly adapt.

The role of the investigator then must include knowledge of both how the machine is operated but also how the organization is operated. Knowing how an aircraft flies safely must be combined with knowing how an organization itself “flies” safely. The cockpit of the aircraft must be tied to the “cockpit” of the board room. An education in Safety Management Systems and a basic implementation guide, such as the one published by Transport

Canada, can be the touchstone for uncovering many issues arising from an investigation. An organization wishing to possess a truly outstanding safety department will have to train its members not only in accident investigation but also in human factors and SMS as well.

As an investigator, it was necessary to look at how the two perspectives in our example managed safety using a basic SMS checklist. In this case, the mere presence of an SMS program was key, as it defined how an organization looked for hazards and what was to be done when they were found. One organization managed risk and the other was more focused on eliminating it. On a deeper level it became clear that the reason why the accident happened was because the people who operated in the accident’s safety culture were simply not asking the same questions as others were.

In the end, it was as astronaut Frank Borman described as a “failure of imagination” when it came to awareness of risk in the Apollo I pad fire. Thanks to a new approach to safety, and the best practices and techniques of SMS, these failures can be mitigated much more effectively now than ever before. Understanding that process needs to be the goal of every safety investigator. ♦

# Investigating Unmanned Aircraft System Accidents

By Thomas A. Farrier (MO3763), Senior Analyst, Aerospace Safety and Operations, Analytic Services, Inc., Arlington, Va., USA



**Tom Farrier** is an aerospace safety and operations senior analyst for Analytic Services, Inc., of Arlington, Va. In addition to working on unmanned aircraft safety for the Federal Aviation Administration's Air Traffic Organization, he supports the U.S. Department of Defense on aviation safety issues.

Tom also serves as a subject matter expert in aviation-related disciplines ranging from homeland security to airline, airport, and heliport safety. A retired U.S. Air Force command pilot, he is a member of the U.S. Air Force Safety Hall of Fame.

*The views expressed in this paper are the author's and do not reflect official positions of Analytic Services, Inc., or its clients, including the Federal Aviation Administration and the Department of Defense.*

## Introduction

It doesn't matter whether you are a friend or a foe of unmanned aircraft systems (UAS). They are coming. Unmanned aircraft systems of virtually every possible type will, at some point in the not-too-distant future, share most classes of airspace with occupied aircraft.

Although the side-by-side operation of manned and unmanned aircraft may at some point become commonplace, unmanned aircraft systems are not yet as advanced to this end as some may wish to assert. This is primarily because the technology itself—especially where it is intended to compensate for UAS' lack of "see-and-avoid" capability—is to some extent still in its infancy. Current UAS operations often are as much research- development-oriented as they are practical applications of mature capability.

Many commercial concerns looking to build and sell unmanned aircraft systems have virtually no prior experience in the aerospace domain, but their desire to gain a foothold in an entirely new kind of market is leading them to innovate. Similarly, many governmental entities perceive great value in the kinds of capabilities that UAS provide, but are not pursuing their development in a consistent manner. These two factors suggest that many practices long held to be "industry standard" in the areas of aircraft manufacture and operations are going either unrecognized or disregarded in the quest to move forward in the UAS arena.

Meanwhile, regulators have been obliged to make many critical decisions regarding the safety of various technologies, operational concepts, and rule-driven requirements for *unmanned* aircraft almost exclusively on the basis of *manned* aircraft experience. None of the processes currently used to evaluate UAS risks and authorize UAS operations were designed with UAS in mind. The long-term correctness of regulatory strategies resulting from these processes will be judged, at least in part, on the nature of safety issues identified through UAS accident investigations. This

means that, for the foreseeable future, *every* UAS investigation carries with it the potential to make a significant contribution to regulatory decision-making.

Regulators have several common goals in their quest to integrate unmanned aircraft systems into their existing airspace systems. They obviously want to prevent midair collisions between UAs and occupied aircraft; they want to minimize the likelihood of UA crashes with the potential to cause loss of life, injury, or property damage on the ground; ideally, they would seek ways of preventing the loss of unmanned aircraft themselves; and they are vitally interested in not creating increased ATC workloads while trying to avoid any of the above.

To these ends, there are three fundamental issues that are being explored in the quest to integrate unmanned aircraft system operations with those of other aircraft:

- To what extent are unmanned aircraft systems capable of operating interactively and cooperatively with other users of the airspace?
- To what extent does the remote location of the pilot from the aircraft he or she is flying affect the safety of the overall activity?
- To what extent are there limits on the number of unmanned aircraft that can be safely operated in a given geographical location, and what drives such limits?

Before being faced with the need to conduct a formal UAS investigation, there are three sources of information—some objective, some inherently partisan—which investigators should cultivate to develop personal perspectives on these issues:

- Manufacturers of unmanned aircraft systems,
- Military operators of unmanned aircraft systems, and
- Non-commercial users of comparable systems (i.e., hobbyist model aircraft pilots).

The balance of this paper is intended to acquaint readers with the basics of unmanned aircraft systems—what they are, how they work, and the hazards they pose—and how that basic knowledge can be applied to investigating UAS accidents. Readers wishing to delve more deeply into the specific of UAS operations and safety concerns should periodically refer back to the three key issues and consult the three principal resources listed above to guide their own self-education process.

## What is an unmanned aircraft system?

There are two possible answers to this question: one that seeks to be descriptive, and one that flirts with being irreverent. In the latter case, the current reply is "Nobody knows!"

There is general agreement by both International Civil Aviation Organization and U.S. Federal Aviation Administration authorities that the flying part of an unmanned aircraft system meets the definition of an "aircraft" for regulatory purposes. However,



beyond that top-level understanding, there is a near-total absence of regulatory language that can shed light on what a UAS is or is not.

Let's back up a moment and regroup. The baseline definition of "aircraft" is a good place to start, especially if you're an air safety investigator. There's a substantial body of knowledge our profession has assembled and can draw upon that's as applicable (with a few caveats discussed below) to a UAS accident as to one involving a widebody passenger jet. This means you don't have to throw out what you already know about accident investigating...you just need to be ready to expand your horizons.

Next, consider the "unmanned" part of the current term of art. There are occasional attempts to render this term more gender-neutral through substitution of the word "uninhabited" as the "U" in UAS. Setting aside the imprecision of that word in the context of an aircraft (as well as it's being a bit more of a mouthful to say), there's some virtue in the general concept it expresses.

For the foreseeable future, there will be no such thing as an occupied UAS, because there is unlikely to be a viable combination of a sufficiently refined business model (or military requirement) and a sufficiently reliable UAS to support passenger operations. So, let's stipulate that an "unmanned aircraft" is an aircraft with no one aboard. So far, so good.

Now comes the tricky part. Special Committee 203 (SC-203) of RTCA developed a working definition that addresses most of the above considerations, but is a bit vague when it comes to the "system" part of the naming convention. In DO-304, *Guidance Material and Considerations for Unmanned Aircraft Systems (March 22, 2007)*, SC-203 defines a UAS as follows:

*An unmanned aircraft system is an unmanned aircraft and its associated elements required to operate in the NAS. An unmanned aircraft (UA) is an aircraft operated without the possibility of direct human intervention from within or on the aircraft.*

*The word "system," as used in this document, includes all elements that make up a UAS.<sup>1</sup>*

As far as the last sentence is concerned, there's a lot of devil in this particular detail. Apart from the design differences that exist among the various types of aircraft meeting the broad definition of "UA," there are a host of possible ways that such aircraft can be controlled "without direct human intervention"—some resident on the airframe itself, and some requiring interactions between a UA and a pilot located elsewhere. However, the means by which control of an unmanned aircraft is effected becomes a relatively small consideration when one acknowledges that a UAS is at once a stand-alone system *and* a part of a far larger, highly structured existing aviation system.

The above discussion illustrates the complexity of the overall UAS issue, as well as the importance of understanding unmanned aircraft systems in terms of the new relationships they bring to the existing aviation system. Many readers probably are aware that there already is a time-tested framework for examining interdependencies within aviation-oriented systems: Professor Elwyn Edwards' 1972 "Software-Hardware-Environment-Liveware" (SHEL) model.<sup>2</sup>

For our purposes, it's essential to remember that the most important principle underlying Edwards' concept is that any change to one component in a system affects the others. Thus, the introduction of an entirely new technology into a working environment should be expected to bring with it the potential for real,

but sometimes unquantifiable, impacts on the people already working in it (manned aircraft pilots and air traffic controllers), and to the existing processes upon which they rely.

Applying the helpful terms of the SHEL model, a UAS has software, hardware, environmental, and liveware components, all of which are subject to management to ensure their correct interaction. The current state of the art includes

- UAS software that's highly variable from system to system,
- UAS hardware that has yet to be defined by any consensus standards,
- an environment consisting of regulated airspace where UAS require several waivers just to gain admittance,
- air traffic controllers who must be specifically briefed on the unique attributes of every UAS operated in their areas of responsibility, and
- the potential for pilots meeting variable standards of aviation knowledge and qualification mixing with other pilots trained to skill levels appropriate to the airspace within which they are permitted to fly.

This last point is the real reason why the term "unmanned aircraft system" is at once imprecise and the best available for what it describes. A UA without a human somewhere in its control loop—either as a pilot or as a programmer—is a non-flying piece of metal. Once that metal is persuaded to become airborne, however, others in the surrounding airspace must be prepared to work with it...preferably on as routine, consistent, and anticlimactic a basis as possible.

In short, the ways humans are involved in, or affected by, UAS operations vary widely from one instance to the next. It is that variability that will provide challenges to investigators of UAS accidents for at least the next decade, if not much longer.

### Unmanned aircraft system segments

SC-203 has done much to develop and elaborate on some fundamental concepts regarding general characteristics of UAS operations. These form a useful basis for discussing the countless impacts and implications of introducing unmanned aircraft systems into the larger aviation system already in operation. At the same time, they introduce terminology that is at times unfamiliar, and they define unmanned aircraft systems from a perspective that requires envisioning how existing users of the aviation system fit into a UAS-centric operational model, instead of the other way around. For all of these reasons, DO-304 should be considered foundational and is worthy of close reading by those interested in keeping up with how the UAS sector is likely to evolve.

One SC-203 concept that is readily applicable to understanding the hazards associated with UAS operations—and by extension, the potential root causes of UAS accidents—is what they term the "segments" of unmanned aircraft systems. In the context of the U.S. National Airspace System (NAS), or for that matter anywhere that a UAS might operate, segments consist of both stand-alone, discrete elements and the interactions among them. As such, the various segments can be aligned reasonably well with the SHEL model, especially in that they are defined in terms of the relationships they have with each other.

The following diagram was developed by SC-203 and included in DO-304 to visually depict the concept of unmanned aircraft system segments.

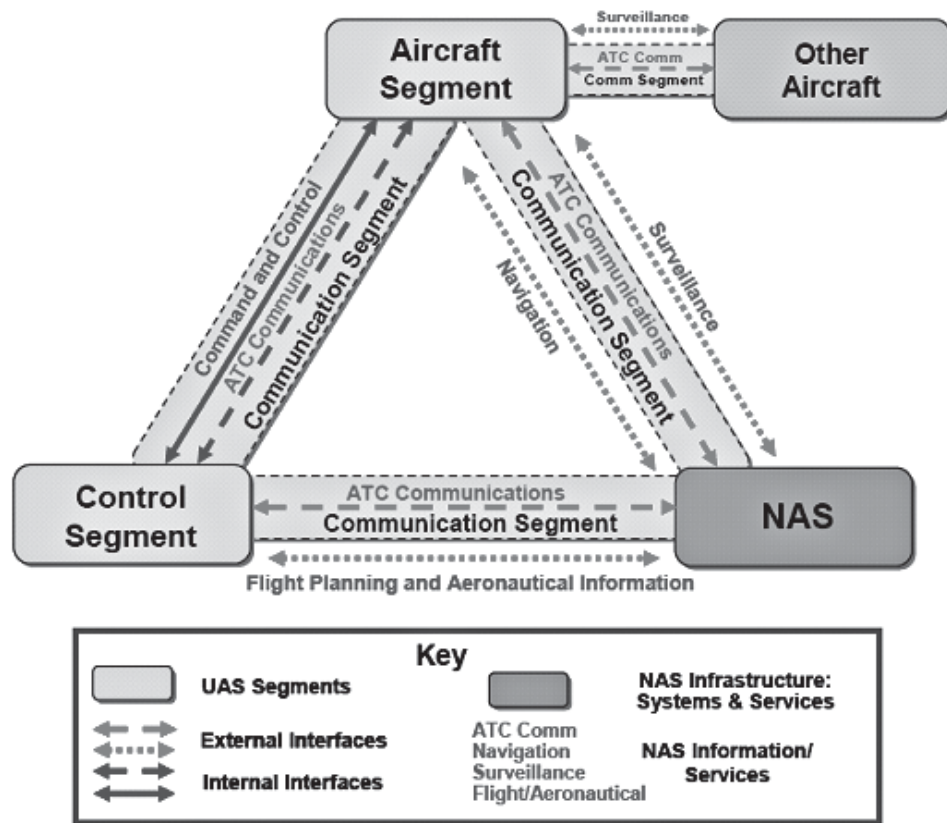

Figure 1. Unmanned aircraft system segments (from DO-304, *Guidance Material and Considerations for Unmanned Aircraft Systems* [March 22, 2007]).

The aircraft segment consists of the UA plus as much (or as little) onboard hardware and software as it requires to conduct a flight from takeoff through landing.<sup>3</sup> At the high end of capabilities, a UA's avionics suite may include a control system (receiving commands and providing aircraft performance and health feedback); a communications relay for beyond line-of-sight operations; navigation, traffic and terrain avoidance, and surveillance systems; and a flight management computer to support in-flight stability and reduce pilot workload. At the opposite extreme, a low-tech, line-of-sight UA may have little more than the ability to receive pilot inputs and turn them into control surface movements.

The control segment consists of the pilot, as well as any non-UA-mounted equipment that supports launch and recovery, flight planning, and flight control and operations. In its simplest form, the control segment may be no more than a pilot with a hand-held controller, with the UA taking off by being hand-started, thrown into the air, and landing via parachute or capture in a net. At the other end of the scale are ground control stations with comprehensive pilot displays and significant automation supporting each mission profile. Also, even though SC-203 did not explicitly address this point, an observer or chase pilot is required for safety purposes should be considered part of this segment. The inclusion of such an individual creates a "segment within a segment," since the observer must communicate directly with the UA pilot.

The communications segment is best understood as the link or links that connect the pilot to the aircraft, and the pilot to the controlling air traffic facility and other sources of aviation-related information. This segment also is intended to encompass any electronic interactions between the UA and other air-

craft that enhance their mutual situational awareness.

Although some readers may argue that other aircraft are in fact part of the larger airspace system within which each UAS operates (i.e., the NAS), the SC-203 separation of the two highlights the fact that controllers and other aircraft each perceive and react to a UAS through different means. This in turn invites safety personnel—including air safety investigators—to explore how those different paths could result in hazards to the manned aircraft, as will be discussed presently.

### How unmanned aircraft systems differ from manned aircraft (and each other)

Let's start with the good news. There's nothing magic about unmanned aircraft systems in and of themselves. Unmanned aircraft fly using the same aerodynamic principles as their heavier- (or lighter-) than-air manned counterparts.

A thorough investigation, using the same familiar techniques of gathering testimony and analyzing evidence, will lead to accurate and useful conclusions in most cases.

Now, the bad news. Unmanned aircraft systems can be different in any number of ways from manned aircraft. Most members of the aviation community key on UAS' inability to clear their own flight path (of which more presently). Small size, and in some cases deliberate design for minimum observability, can make it equally hard for other aircraft to acquire and avoid them as well.

However, there are many other subtle and unsubtle differences that have a bearing on their relative safety within, and impact on, manned aircraft sharing the skies with them. For example, the design of any unmanned aircraft system intended for operation beyond the pilot's line of sight must support the pilot's situational awareness in terms of flight conditions, aircraft performance, and the health of the vehicle itself.

Unfortunately, the more information needed to provide such awareness, the more bandwidth is required to provide it. Therefore, it is left to each manufacturer to make tradeoffs and risk decisions regarding the level of detail and sampling rates required to substitute for the pilot's inability to directly perceive turbulence, precipitation, ice accumulation, a growing high-frequency vibration, or the smell of a short-circuit.

Along these same lines, there are a whole range of hazardous situations that can result from the pilot not being located in the aircraft. These may include anything from the consequences of the pilot losing control of the aircraft to the pilot not being aware of what's happening to the aircraft. In addition, the wide variability in performance and equipment among individual systems means that there are few hard and fast rules regarding their relative abilities to safely interact with other aircraft. Rather, this variability greatly complicates the investigator's task, since any given UAS

involved in an accident must be assessed based on its specific configuration, capabilities, and limitations.

To gain a deeper appreciation for the countless combinations of performance, capabilities, and physical attributes associated with unmanned aircraft across the size and complexity spectrum, the reader is invited to pick three systems of different sizes at random (if I did it, I'd be accused of stacking the deck) and compare them against one another based on the following:

- Vehicle length,
- Vehicle wingspan,
- Vehicle takeoff gross weight,
- Maximum rate of climb/descent,
- Service ceiling,
- Climb/cruise/dash/loiter/approach airspeeds,
- Line-of-sight/beyond-line-of-sight operations,
- Echelon of control (military only),
- Vehicle applications (surveillance, etc.),
- Type of ground control (line of sight, internal/external, distributed, etc.),
- Capability for autonomous flight (e.g., fully preprogrammed mission with minimum pilot intervention, autonomous during periods of control link loss, etc.), and
- Lost link behavior (e.g., return to origin, fly to predetermined or reprogrammable orbit point, initiate termination system, etc.).

Much of this data is publicly available, but not always in a form that lends itself to apples-to-apples comparison. However, the simple act of going through this exercise will do much to raise one's awareness of just how complicated the process of categorizing or classifying unmanned aircraft systems within a consistent regulatory structure is going to be. It's almost impossible to develop a meaningful set of thresholds for aircraft that are so different in appearance, behavior, and applications. The results of accident investigations must be used to inform the ongoing dialogue that is in progress on these issues.

Finally, the nature of individual UAS construction and capabilities also has the potential to mislead investigators attempting to piece together an accident sequence. For example, when faced with an apparent inflight break-up, an investigator could face two completely opposite scenarios:

- Some military unmanned aircraft may be significantly more structurally robust than manned aircraft, simply because they are intended to be capable of high-performance maneuvering not limited by the physical limitations of occupants. An inflight break-up of such an aircraft could indicate a serious design flaw, or possibly a failure of control laws that subjected it to extreme stresses.
- Many unmanned aircraft—especially those designed for long endurance flight—may be *less* structurally robust than manned aircraft, since they are optimized for weight savings and don't need to incorporate crash resistance features. An inflight break-up of this type of aircraft could indicate that the pilot knowingly (or unknowingly) flew it into flight conditions that exceeded its limits, or perhaps that the margins of safety for a flight-critical component need to be slightly strengthened.

The bottom line is that it is impossible to generalize about unmanned aircraft systems, either in terms of how they work or as a means of making judgments as to UAS attributes that may have been factors in a given accident. Until widely accepted standards of manufacture, certification, and operation are adopted, every investigation must be approached with a clean piece of

paper, a willingness to ask seemingly over-simplified questions, and a total lack of preconceptions.

### Sources of potential accident risk in unmanned aircraft systems

Most present-day unmanned aircraft systems are in relatively early stages of development, and there is little in the way of standardization among the various components of different manufacturers' systems. This means that problems are continuously being identified in three main areas.

- Aircraft-specific reliability (structure, propulsion system, autopilot/flight management or control system, and on-board system interfaces),
- Control link stability and reliability (past performance, frequencies used, lost link behavior), and
- Human performance, especially with respect to how information flows between the control and aircraft segments and how to ensure the timely and appropriate selection of whatever subset of that information needs to be presented to the pilot based on the UA's current phase of flight.

To the latter point, human factors in unmanned aircraft systems is emerging as a significant area of inquiry for research projects and should be followed closely by the investigation community. For example, one recent study<sup>4</sup> suggests that three common scenarios under which accidents occur involve direct-control operations (where "external pilots" operate the UA by observing its movements visually as they operate a hand-held control device); transfer of control problems (where some defect occurs when a pilot shifts control of a UA in flight to another pilot or control station); and interestingly, automation-induced events (where the pilot is either unaware of the need to intervene in an operation or, conversely, is unable to intervene when the need to do so exists).<sup>5</sup>

Although it is useful to be aware of the importance of these fairly narrowly focused issues, it is equally useful for investigators to have at least a general sense of the principal hazards associated with UAS operations. Such hazards may be mitigated by various combinations of design features and procedural controls, which themselves need to be subject to continuous evaluation for their proper operation and overall effectiveness.

In the absence of existing regulations to the above ends, the U.S. Federal Aviation Administration (FAA) has made three broad policy determinations as an interim measure to ensure essential access to the NAS by unmanned aircraft systems for the purposes of military readiness, research and development, and other activities of national-level interest:

- UAS operations outside regulatory special use airspace as defined in Title 14, Code of Federal Regulations (14 CFR), Part 73 may only be conducted under a Certificate of Waiver or Authorization (COA) issued in accordance with FAA Order 7210.3, *Facility Operation and Administration*, Chapter 18 ("Waivers, Authorizations, and Exemptions"), or pursuant to the FAA/DOD *Memorandum of Agreement for Operation of Unmanned Aircraft Systems in the National Airspace System*, Sept. 24, 2007.
- COAs are issued only for UAS that meet the definition of "public aircraft" as provided in 14 CFR §1.1, and their operators are limited to public entities or contractors to those entities.
- Any operator other than those described above may not apply for COAs at this time, but is free to seek a special airworthiness certificate—experimental category—if they wish to fly in the NAS.



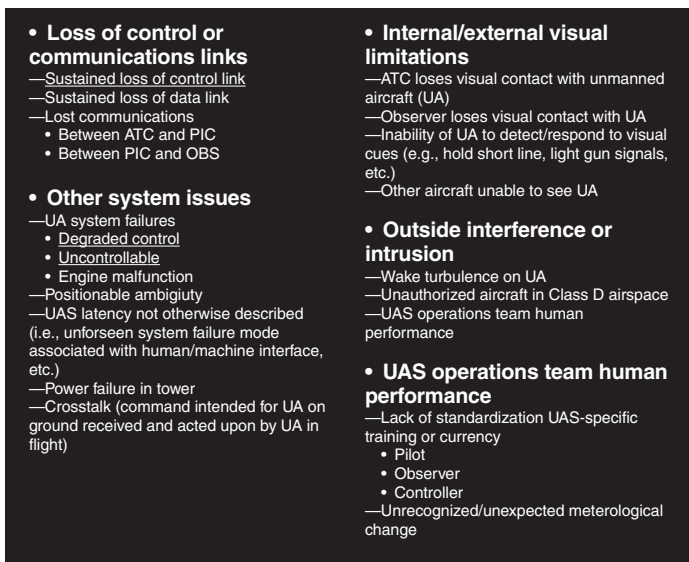

Figure 2. Class D airspace UAS-related hazards.

The key to the above is that all of these policy-based controls must of necessity be *interim* measures. It is clear to all concerned that the growth of UAS activity in the United States soon will overwhelm the FAA's ability to manage individual UAS operators' activities. Therefore, the COA process owner—the FAA's Air Traffic Organization (ATO)—has been developing a means of assessing UAS hazards as they affect other aircraft in, and controllers of, regulated airspace. Their approach is based on one of the main components of the FAA's Safety Management System: the Safety Risk Management (SRM) process.<sup>6</sup>

Throughout 2007, the ATO had a team of experts evaluating the various hazards that could be reasonably expected to be encountered in the course of UAS operations in Class D airspace. This panel generated the following list:

The three hazards underlined in Figure 2—sustained loss of control link and system failures resulting in degraded or total loss of control—were assessed as “initial high risks” by the panelist. While the specific assessments and the recommendations for reducing the residual risk are still undergoing formal review, the implications are clear: a lot can go wrong with a UAS in the confines of Class D airspace that can quickly lead to significant risk to persons and property in the air and on the ground.<sup>7</sup>

Investigators are invited to consider the above list as a starting point for development of a list of generic issues that should be explored in the context of each UAS-related investigation. Determining how specific attributes of the various types of unmanned aircraft systems may be related to these hazards is discussed in the next section.

### Planning and carrying out a UAS investigation

The simplest way to approach a UAS investigation is to treat it exactly as you would any other aircraft investigation: systematically, deliberately, and scaled appropriate to the loss sustained. However, the only way you can do that in real time is by preparing well in advance and building understanding of the different aspects of unmanned aircraft systems and operations to which you will have to pay special attention.

There is one indisputable fact about unmanned aircraft system accidents: unless it has been a VERY bad day, an investigator

pretty much always will have a live pilot to interview. Beyond that, virtually every accident investigation will be heavily dependent on the nature and specific capabilities of the involved vehicle and systems.

As explained above, at present, there is no reliable, consistent taxonomy that permits the categorization or classification of the vast array of possible UAS configurations. Similarly, there is no such thing as a “standard” UAS—almost every one incorporates design features and performance attributes unique to the individual system. Terminology for various system components also tends to vary from one manufacturer to the next, meaning it is sometimes difficult to fully understand exactly how a given system works until you can equate its logic to that of other systems with which you may be more familiar.

Notwithstanding the above, it is possible to construct a list of generally descriptive questions that can help drive the investigation in productive directions with a minimum of wasted time. For example,

1. Propulsion: What type of engine does the aircraft use and how is it powered, e.g., AVGAS, MOGAS, diesel, Jet-A/JP-8, special fuel, electric (solar or battery-powered), etc.? Is the powerplant certified for aviation use, was it built specifically for the unmanned aircraft, or was it adapted from an existing engine used for other purposes? Are there any unusual components that might pose hazards to investigators in the field following a crash (capacitors with high residual charges, fuel cells, etc.)?

2. Control: How does the pilot control the aircraft? Does the system incorporate a hand-held controller, a fully equipped ground control station, or both? What type of instrument layout is used by the pilot for control, navigation, communications, and mission execution? To what extent does the aircraft provide information to the pilot about its operating conditions and environment, such as turbulence, icing, vibration, overheat/fire, etc.? If the control link is lost, what is the aircraft designed to do, and how much time normally will elapse before it autonomously executes a course change or termination subroutine? Does lost link behavior change throughout the flight, or is it preprogrammed?

3. Operations: Is the aircraft designed for line-of-sight operations only, or is it intended to be operated beyond visual range? If the latter, how does the pilot maintain contact with the aircraft and with the ATC facility responsible for its area of operations? How does the pilot navigate? Does the navigation system afford the pilot the ability to change heading, altitude and airspeed at will or as directed by air traffic control? Can the pilot identify and proceed to navigational fixes and waypoints upon request?

4. Collision vulnerability: What does the aircraft look like? Is it a highly visible color, or designed to be difficult to visually detect? Does it incorporate position and/or anti-collision lights? On the size spectrum, is it closer in wingspan to a manned aircraft, or is it more model-like? Given that kinetic energy is expressed as  $KE = \frac{1}{2}mv^2$ , how fast is it designed to fly, and how much does it weigh?

5. Construction: What is the aircraft made of? Does it consist of aviation-grade components, or is it essentially off-the-shelf in manufacture? Is the aircraft made of primarily radar-transparent or radar absorbent materials, such that it would generate little or no primary radar return in normal operations? If so, does the aircraft incorporate a transponder?

6. Flight systems: What avionics are used to support the UAS' operation? Are radios TSO-compliant? What frequencies are used

for line-of-sight and beyond-line-of-sight control? Are there local sources of radiomagnetic frequency interference that could affect the communications segment? Does the aircraft have any ability to detect and react to conflicting traffic? What sources of electrical power are aboard the aircraft, and if they are interrupted or degraded, are there automatic protocols for load-shedding that help ensure its safe recovery?

7. Payload: What kind of payloads can the UA carry? Is any part of that payload potentially hazardous? Does the payload draw on aircraft power, or does it have its own power supply? Is the payload used to support flight operations, e.g., an optics ball aimed in the direction of flight? If so, how is its use coordinated with the needs of the pilot?<sup>8</sup>

8. Flight data: Does the UAS ground control station typically record flight performance and other relevant data during normal GCS operations? What parameters are captured, and in what format? What is the sampling rate? How long are such data retained? Are there recordings available that show a similar profile to the one being flown at the time of the accident that can be compared with the accident sequence? Does loss of the control link also result in loss of downlinked performance and health data? Is there any on-board recording device that can fill gaps in the data stream? Is the recorded data compatible with any flight visualization software?

The above questions, used in combination with an investigator's preferred practices and checklists, should support a thorough, well-documented investigation of most UAS-related accidents and incidents, as well as yielding useful factual information upon which to develop credible recommendations.

The peculiar nature of UAS design and operation also lends itself to a "systems" approach to investigation that may be useful in some complicated scenarios where root cause is not easily identifiable. This involves arraying the specific components of the UAS under investigation against the SC-203 "segment" diagram shown in Figure 1. Any disruptions in the interactions among the various segments or internal to one segment should be mapped on a timeline and traced to their source. This method will tend to highlight how one failure—say, loss of performance feedback from the flight control actuators to the flight management computer—can quickly cascade into faulty data to the pilot and inappropriate commands back to the flight control actuators.

One final consideration: For any investigation involving a reasonably sophisticated UAS, it would be prudent to have a software engineer as a part of the investigation, either as a member or in a consulting capacity. Some off-the-shelf approaches to controlling and stabilizing unmanned aircraft involve taking existing sets of control laws in one computer language, applying those laws to control link inputs that arrive in a different format, and then translating the resulting commands to the flight control actuators in yet another operating language. If the UAS is self-stabilizing and/or has the ability to carry out complex lost link behavior, that means that all of those on-board communications will be two-way to enable self-correction and response to on-board navigation inputs.

The sheer complexity of many such arrangements makes finding software defects a daunting task for virtually anyone lacking specific subject matter knowledge. Proprietary conversion or control protocols, as well as the inclusion of control command encryption in a system, make it virtually essential to bring an independent expert into the investigation from the outset.

### Making useful recommendations

The point has been made elsewhere in this paper that the majority of UAS operations conducted anywhere in the world today have been enabled by a patchwork of regulations, policies, waivers, and assumed "best practices." For at least the next decade, as efforts to normalize UAS activity and integrate it into civil airspace move ahead, air safety investigators must help identify the mitigations that work, and the ones that don't.

In developing UAS-related accident recommendations, it is important to examine each accident sequence in the context of how the UAS operation was being carried out. For example,

- Was the UAS conforming in all respects to the flight rules applicable to manned aircraft operations at the accident location? If not, what regulations (if any) were waived for the UAS, and did those waivers have any bearing on the occurrence?
- Was the UAS activity being performed at the time of the accident suitable to the airspace and altitude at which it was conducted? Was the activity consistent with the design and performance of the UAS itself?
- Would a manned aircraft operating under the same conditions have been equally likely to have been involved in an accident, or did some property or characteristic of the UAS start or sustain the accident sequence?

Then, the investigator must determine what aspects of the accident sequence might have been better controlled had different mitigations been in place. This will require fully documenting the exact configuration and capabilities of the involved UAS; understanding each hazard resulting from the combination of UAS and flight activity under consideration; and assessing the scope, quality, reliability, and proper implementation of each mitigation asserted as having been in place with the intent of interrupting an accident sequence before a worst-case outcome could occur. This should allow a gap analysis between what was being done, and what was not done, to prevent the accident.

Finally, the quality of pilot/operator decision-making will need to be subjected to close scrutiny in considering whether any recommendations need to be made toward limiting the opportunity for bad practices or bad choices to adversely affect the public at large.<sup>9</sup> This set of issues has not required conscious addressing for many years. The present-day framework of regulations governing aviation has significantly evolved over time, and organizations like the Air Line Pilots Association and others have successfully pressed their case for "one level of safety" to great effect in most types of commercial operations. However, for now, unmanned aircraft systems are operating loosely under general-aviation-type rules, which may not be suitable for two fundamental reasons.

First, unlike any other class and category of aircraft, the pilot of an unmanned aircraft is *never* at risk of physical harm. Pilots make decisions about their flights based on a variety of inputs, but many inflight judgments carry with them the implication of serious, possibly mortal injury should they prove incorrect. As such, aviation regulations are written somewhat from the same point of view as traffic rules—once taught the meaning and purpose of a double yellow line, drivers understand they have a vested interest in not crossing one on a blind hill.

Second, unlike most manned aircraft, the simplicity and relatively low cost of bottom-end UAS carries with it the possibility of an unmanned aircraft being looked upon as being expendable. In a growing number of cases, the most valuable part of an un-

manned aircraft is its payload, usually followed by its engine. If an operator of a UAS will not suffer serious financial harm from casual or negligent operation of it, and if there is little likelihood of a destroyed aircraft being traced back to them, there is less incentive to be responsible participants in the aviation system.

The latter possibility begs an obvious question: how useful or relevant are investigations of accidents where at least one of the involved assets is considered disposable? As has been noted several times throughout this paper, there are no easy answers to issues like this, but answer them we must.

## Conclusion

Unmanned aircraft systems will, sooner or later, become a significant sector of the overall aviation community. That means that they also will be involved in accidents, and as equal partners in aviation safety, their operators and pilots will have to learn from those accidents. If they do not accept their responsibility to others in the shared environment of aviation operations, they should not be permitted access to it.

UAS investigations in the coming years need to take into consideration all of the regulatory issues raised in this paper, as well as those technical issues more commonly at the heart of most aviation accidents. There are strong commercial incentives driving interest in placing unmanned aircraft systems in urban areas, in the heart of the most congested airspace, and in the same environment used by current operators of a whole range of light aircraft and helicopters. Air safety investigators must be objective judges of the extent to which both administrative and technological protections will be needed to keep these current users safe today and tomorrow while providing for the appropriate and evolutionary growth of the UAS sector. ♦

## Appendix A

### Identification of Unmanned Aircraft System Hazards Through The Federal Aviation Administration Safety Risk Management Process

In its customary application, the Safety Risk Management (SRM) process is triggered by a proposal to change any part of the NAS. If that change is determined to have the potential to affect the

safety of the NAS, it becomes obligatory to formally explore the hazards and resulting risks stemming from the change. This process is illustrated in Figure A-1.

Obviously, the introduction of unmanned aircraft systems in the NAS represents such a change of the type anticipated by the SRM process—possibly the most significant change since the introduction of jet air carrier operations in the mid-1950s. Equally important, this change may reasonably be expected to adversely affect the safety of the system as a whole if not accomplished responsibly. Therefore, by definition, the SRM process should be applied to the issue, and a Safety Risk Management Document (SRMD) of some type normally would be required to either permit or deny the change.

At this point, the challenge was to determine the best means of applying the SRM process to the system-level changes associated with UAS operations. Essentially, there were two options for doing so

1. Treat each new application for a certificate of waiver or authorization (COA) as an individual change subject to the SRM process, preparing a new SRMD for each as a part of the application process *or*
2. Accept the existing COA process as sufficient for maintaining the safety of the NAS in the near term, and use SRMDs to support both the review of individual COAs today *and* UAS-related rulemaking as it evolves.

The COA process is designed to gather all information required for informed decisions regarding the acceptability of each application and does so very effectively. Nevertheless, there is obvious value in subjecting various aspects of UAS integration to more detailed analysis, especially as rulemaking efforts intended to accommodate them move forward. For that reason, the second option was selected. However, the integration of UAS into the NAS was deemed too complex and encompassing a change to be addressed through a single SRMD. Therefore, the SRM process was adapted for use as a framework for systematic review of the various hazards associated with UAS operations in different classes of airspace.

The first SRMD created under this approach considered the risks associated with operating unmanned aircraft systems in Class D airspace. The panelists appointed to develop the SRMD's preliminary hazard assessment followed a deliberate strategy of identifying as hazards any conditions that

could be reasonably expected to result in risk in conjunction with the operation of at least some—but not necessarily all—types of UAS in the Class D environment. The panel then determined the worst credible potential outcome for each hazard based on the specific UAS attribute or attributes seen as resulting in the most severe consequences in the context of that hazard.

Class D airspace represented a good starting point for several reasons. First, U.S. military operators of UAS had an urgent need to expand UAS activity at a number of locations where the services manage non-joint

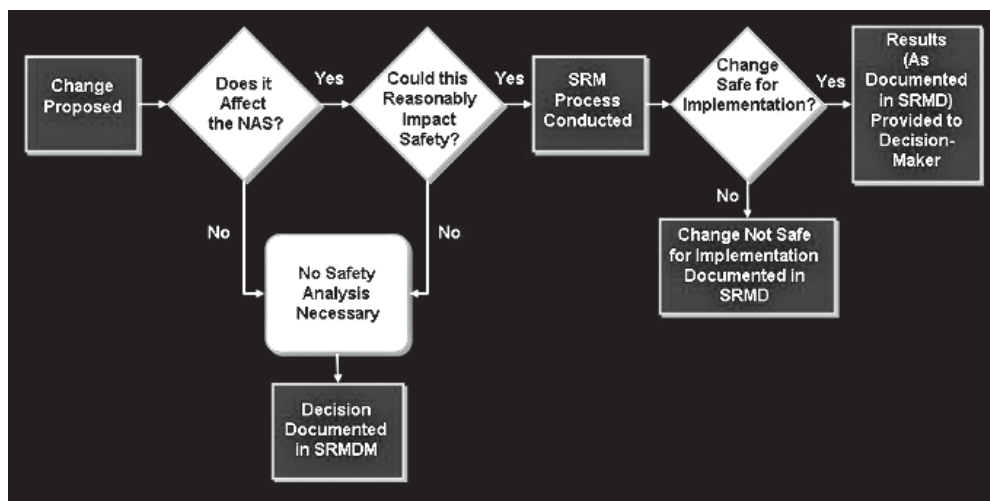

Figure A-1. Determining requirements for a FAA Safety Risk Management Document.



use (i.e., military only) Class D airspace. Second, there is a clearly articulated minimum regulatory requirement for aviation operations in Class D airspace, namely, the requirement for two-way radio contact with air traffic control (14 CFR 91.129). Also, the nature of operations in Class D airspace lend themselves to being generally characterized by aircraft convergence and a corresponding density of aircraft in the vicinity of the primary airport for which the Class D airspace has been created. Finally, a mix of manned and unmanned aircraft is ensured in Class D airspace by virtue of both types conducting takeoff and landing operations from the same airfield.

In the Class D environment, the panel concluded that there was one discriminating factor that could be used to help with the assessment of individual hazards. Specifically, the panel distinguished between UAS that require runways to operate versus those that can take off and land without runways. This criterion was repeatedly used by the panelists in cases where the hazard under consideration might involve air traffic control impacts (collision hazards, increased controller workload, etc.). Then, assumptions were made to guide the panel's deliberations toward consistent conclusions for each hazard assessed. Paraphrased, these assumptions included the following:

1. Each hazard shall be assessed on the basis of the most likely UA activity to be encountered or affected; therefore, recommended mitigations will be generic in nature.
2. UAS operators and aircraft must comply with the existing federal aviation regulations (FARs) except when specifically exempted by the FAA; in those cases where a UAS cannot comply with applicable FARs (for example, because no individual is on board to perform "see and avoid"), the panel will search for alternative mitigations.
3. If a UAS operator has complied with established FAA airworthiness rules, met certification/qualification requirements, and been granted an FAA COA or an FAA special airworthiness certificate consistent with the controls and mitigations contained in the Class D airspace SRMD, the panel assumed that the operator has mitigated the risks identified in applicable FAA policy standards.
4. Operational practices in use under approved COAs that reduce the severity or likelihood of individual hazards are to be recognized as "existing controls" within the Preliminary Hazard Analysis; all such controls must be confirmed to be in place for every proposed UA operation where those hazards may be encountered.
5. The role of the observer is to maintain visual line-of-sight contact with the UA while scanning the environment in which the UA operates to identify other aircraft that may require traffic deconfliction; a properly qualified observer who maintains continuous visual contact with the UA, and who is in direct communication with the pilot, is capable of assisting the pilot in deconflicting traffic.
6. UAS pilot(s) will have direct communication with ATC; ground observers are not required to have direct communication with ATC during UA operations.
7. UAS operations in Class D airspace at present are not conducted over populated areas.
8. A hull loss of a UA may not always result in a "catastrophic" level of severity because no human being is aboard.

The result of this process—the so-called "Class D SRMD"—is currently undergoing top-level review within the FAA. The haz-

ards and risks the SRMD identified are discussed in the main body of this paper.

## Appendix B

### The Criticality of UAS "See-and-Avoid" Limitations

It is common for those concerned with UAS safety to focus on the lack of an onboard pilot as being the overarching consideration that must be addressed. However, the real key is right of way, which was the driving force behind the general "see and avoid" standard found in most contemporary operating regulations.

On Jan. 1, 1932, the U.S. Department of Commerce's Aeronautics Branch published *Aeronautics Bulletin No. 7—Air Commerce Regulations*, a 34-page document representing one of the first written compendiums of rules governing licensing, marking, inspection and operation of aircraft, licensing of pilots and mechanics, and air traffic rules. The latter consisted of just more than five pages, but one full page was dedicated to explaining how each pilot was to determine if they had the right of way when encountering another aircraft. This was the core concern; the section setting forth these procedures was called, very simply, "Flying Rules."

By 1943, the civil air regulations had greatly expanded in content and detail, but their general preoccupation with right of way persisted. A new element—"Proximity in Flight"—was added as well, requiring pilots to keep at least 500 feet away from each other except by prearrangement. In defining right of way and the notion of minimum safe separation, the U.S. Civil Aeronautics Administration laid the foundation for the entire notion of see-and-avoid. However, it's important to bear in mind the reasons behind why that concept emerged; they are at the core of the ultimate goal of preventing midair collisions by ensuring consistent behavior by all aircraft through direct reference to each other's route of flight.

The inability of a UAS to see-and-avoid has been at the center of many debates regarding the hazard an unmanned aircraft poses to others. However, the FAA ATO Class D SRMD panel's assessment suggested that time and space separation of UAS from other aircraft, combined with a visual observer, significantly reduces the likelihood of a collision.

Use of various "sense-and-avoid" technologies may actually result in a somewhat *less* safe environment in busy airspace, for two reasons:

1. The failure of a UA's sense and avoid (S&A) system could pose an immediate hazard to surrounding aircraft if the mitigations currently in place are discarded when S&A technology becomes technological feasible.
2. Unless the avoidance maneuver resulting from an S&A system's detection of a conflict is standardized and fully understood, it could result in confusion on the part of pilots who themselves have seen and begun to respond to an impending conflict with an unmanned aircraft.

The implementation and refinement of Traffic Alert and Collision Avoidance Systems (TCAS) has made two points clear to the entire aviation community. First, there is room for fatal error any time pilots and air traffic controllers receive and attempt to react to independent indications of a conflict known only to one party or the other. Second, the act of "avoidance" itself must be

standardized and purposeful; if aircrews are trained to trust their equipment and follow its direction, it will keep them safe.

Time and again, the safety of any given UAS in any environment seems to come down to one simple concern: its *predictability*. The right of way of individual UAS is not separately defined from that of analogous manned aircraft, and unmanned aircraft rarely are capable of keeping their distance from other aircraft, clouds, or terrain without pilot intervention. Therefore, it is convenient to cluster these specific concerns under the umbrella of see-and-avoid. However, the real issue is what other pilots can expect of a UA they encounter in flight. For now, there is no good answer to that core concern.

## Appendix C

### The Worst-Case Scenario: Midair Collisions Between Manned And Unmanned Aircraft

Everyone in the UAS community acknowledges that the worst possible accident—in terms of both direct consequences and the likely effect on public acceptance of UAS operations—would be a collision between a manned and unmanned aircraft. Unfortunately, such an accident seems not only plausible, but also reasonably likely given many of the applications envisioned for future unmanned aircraft systems in the civil sector.

While proponents of UAS expansion are justifiably wary of being involved in an accident with a commercial air carrier, they seem much less attuned to the likelihood of undesired and unexpected interactions with manned aircraft performing the same kinds of activities that they advocate carrying out with unmanned aircraft systems. For example, there are 20 generally recognized uses of civilian helicopters—

- Agriculture (Part 137)
- Air carrier (Part 127)
- Air taxi (on-demand, Part 135)
- Air Tour (scheduled/on-demand, Part 135)
- Electronic news gathering
- Emergency medical services
- Executive transport
- Exploration
- External cargo (Part 133)
- Forestry
- Government contract operations
- Herding
- Law enforcement
- Logging
- Offshore oil and gas platform support
- Photography
- Pollution monitoring
- Skiing
- Traffic surveillance

- Utilities patrol and construction

Many of these activities could be accomplished economically by unmanned aircraft systems that exist today. Taking this observation to its natural conclusion, it seems inevitable that manned aircraft (especially helicopters) and unmanned aircraft performing similar or related activities will come in close proximity to each other on a regular basis as UAS operations become widespread.

This in turn means that collision likelihood at certain locations—for example, over the scene of a major traffic accident—may be expected to be substantially greater if unmanned aircraft lacking a standard technological means of avoiding other aircraft are permitted to engage in traffic surveillance or electronic news gathering operations at will.

Assuming a threat of this type evolves along the lines suggested above, investigators may find themselves responding to the scene of a manned aircraft accident only to discover that an unmanned aircraft may have been involved in the sequence of events. Should that be the case, it may open the door to a host of new mitigation requirements, and it will be up to air safety investigators to make the case for them.

### Endnotes

- 1 DO-304, Guidance Material and Considerations for Unmanned Aircraft Systems (March 22, 2007), RTCA, Inc., (Washington, DC: 2007), p. 3.
- 2 See Civil Aviation Authority [U.K.], CAP 719: Fundamental Human Factors Concepts (2002), available at [www.caa.co.uk](http://www.caa.co.uk), for a brief overview of this model.
- 3 The DO-304 model deliberately excludes any reference to the UA's payload—camera, sensors, etc.—in describing the aircraft control segment. This seems to beg several questions, including the precision of navigation control required for the design mission, the power demands of the payload on the UA's electrical system, and safety-of-flight practices involving the use of payload capabilities to help clear the UA's flight path, look for reported traffic, etc.
- 4 Human Factors Implications of Unmanned Aircraft Accidents: Flight-Control Problems, DOT/FAA/AM-06/8 (Washington, DC: Federal Aviation Administration, Office of Aerospace Medicine, April 2006).
- 5 An excellent compendium of these issues may be found in Eduardo Salas and Nancy J. Cooke, et al., *Human Factors of Remotely Operated Vehicles* (San Diego, CA, USA: Elsevier, Ltd., 2006). More than half of its content can be related to various aspects of UAS hazards and challenges raised throughout this paper.
- 6 See Appendix A for a discussion of how the FAA ATO SRM process is being applied to the challenges of UAS integration.
- 7 Some readers may be puzzled by the absence of a “midair collision” hazard in the SRMD list. This is because the SRM hazard assessment process holds a midair collision to be a potential outcome of a hazard, not a hazard per se. Thus, the possibility of midair collision drove the “severity” assessment in the evaluation of the various hazards listed. See Appendix B for a brief discussion of the relationship of the “see and avoid” requirement to the actual needs of safety in flight.
- 8 Onboard video, if available, can be a useful diagnostic tool if a midair collision, unexpected flight into terrain or an obstacle, or a similar “external” is suspected. However, if a vehicle's control link is lost at the start of the accident sequence, about the best you can hope to learn from such visual information is whether the UA executed its lost link behavior properly. While it's a novel experience to watch an actual pilot's eye view of a crash, after one or two viewings, investigators will probably determine that their time may be better spent elsewhere.
- 9 See Appendix C for a brief discussion of the circumstances under which UAS and manned aircraft are most likely to come into conflict.

# Occupant Protection—A Case Study Bombardier Challenger CL-600, Teterboro, N.J., Feb. 2, 2005

By Nora C. Marshall (MO3036), Chief, Survival Factors Division, Office of Aviation Safety,  
National Transportation Safety Board (Presented by Frank Hilldrup)

*Nora C. Marshall has been an investigator at the National Transportation Safety Board since June 1984 and was selected as chief of the Office of Aviation Safety's Survival Factors Division in May 2000. She has conducted more than 150 survival factors investigations. She co-authored the Board's safety study on emergency evacuation, the Board's safety study on airline passenger safety education, and authored the special investigation report "Flight Attendant Training and Performance During Emergency Situations." Before joining the Safety Board's staff, Marshall was a flight attendant, flight attendant supervisor, and emergency procedures instructor for World Airways. She is a member of the International Society of Air Safety Investigators (ISASI). She is a graduate of the University of California, Santa Barbara, and holds a bachelor of arts degree in anthropology.*

For this paper, I have selected an accident investigation that highlights the most basic cabin safety issues such as cabin security, seatbelt usage, knowledge of emergency exits, and company safety training. Although all of the occupants survived the accident, passenger interviews and thorough documentation of the cabin uncovered surprising noncompliance with basic cabin safety regulations. In addition, this paper will discuss the effectiveness of a high reach extendable turret (HRET) used by aircraft rescue and firefighting (ARFF) crews in extinguishing an interior fire at Teterboro and during other accidents involving interior fires.

In February 2005, a Bombardier Challenger CL-600 overran the departure end of Runway 6 at Teterboro Airport (TEB) at a ground speed of about 110 knots. The airplane traveled through an airport perimeter fence and struck an automobile as it crossed a six-lane highway and a parking lot before impacting a brick building. The two pilots and two people in the automobile were seriously injured. The "cabin aide," eight passengers and one person in the building received minor injuries.

After the airplane stopped, both pilots reported being trapped in their seats because their legs were entangled in the rudder pedals and wreckage that intruded through the cockpit floor. The pilots stated that there was an urgent need to evacuate because they could see smoke and flames. The captain shut down the engines and master battery switch and then grabbed the first officer by the belt and pulled on his lower body while the first officer pulled on an overhead bar with his arms. Through these efforts, the pilots were able to free the first officer's legs from the wreckage. The first officer reported that he was then able to crawl out the main cabin door. Once he was outside the airplane, he crawled over the wing and two passengers helped pull him away from the airplane.

Similarly, after the captain freed his legs from the wreckage he crawled through the cabin area to ensure that everyone was out of the airplane before he exited through the main cabin door. Although he did not see the cabin aide, he knew that she was not on the airplane because of his cabin check and because passengers told him they had seen her outside the airplane.

The cabin aide unbuckled her seatbelt and moved to open the main cabin door. She told investigators that she believed that she "got the lever open" and that she then tried to use the electric "lever at the top [of the bulkhead] but it was not working." Passengers began pushing and kicking the door, and it eventually opened. The cabin aide jumped out and ran away from the airplane. She was picked up by a passerby in an automobile, was driven to an ambulance, and was subsequently taken to a hospital.

All eight passengers were interviewed, and six of the passengers reported that they had not received a preflight safety briefing before takeoff. Two passengers remembered the captain addressing them; one said it was a "short briefing," and the other indicated that if he had received a safety briefing he would have fastened his seatbelt. Many of the passengers received beverages after they boarded, and the beverages were served in glasses or ceramic/china cups. Several glasses or cups were recovered on or near passenger seats during the investigation. A passenger in an aft row stated that he picked up his coffee cup during the takeoff roll to prevent spillage and believed that the broken coffee cup caused the injuries he received to his hand.

Passenger interviews indicated that only four of the eight passengers had their seatbelts fastened when the takeoff roll began. Two of the four passengers fastened their seatbelts during the takeoff roll, and two passengers seated on the divan could not locate their seatbelts and were therefore unrestrained throughout the event. The two unrestrained passengers were thrown to the cabin floor during the accident sequence.

Post-accident examinations revealed that the seatbelts at the three divan seats would not have been visible to the passengers because they had been intentionally placed beneath the seatback cushions. Positioning seatbelts beneath the seatback cushions resulted in a tidier passenger cabin and was reportedly not uncommon among operators of corporate and charter airplanes. However, with the seatbelts stowed in this position, passengers would have had to either blindly reach behind the seatback cushions or remove the cushions to locate the seatbelts. The Safety Board concluded that the intentional positioning of the seatbelts out of the passengers' sight made them difficult to locate and use and resulted in reduced compliance with passenger seatbelt usage



requirements. The Board recommended that the FAA require all 14 CFR Part 135 certificate holders to ensure that seatbelts at all seat positions are visible and accessible to passengers before each flight.

Passengers reported that the cabin was dark and smoky when the airplane stopped. The cabin aide had not opened the main cabin door so a passenger from one of the forward seats felt around the door until he found the door handle, which he then rotated. When the door did not open, he pushed and kicked it. With the help of another passenger, he eventually was able to open the main cabin door and passengers and the cabin aide evacuated. Although the cabin aide indicated that she evacuated behind all of the passengers, at least two passengers reported that she exited before them. The Board concluded that the cabin aide's training did not adequately prepare her to perform the duties with which she was tasked, including opening the main cabin door during emergencies.

Although a flight attendant was not required on the flight, the Safety Board evaluated the cabin aide's actions, performance, and training. The operator's documentation and guidance regarding cabin aide and flight crew responsibilities were unclear; however, the cabin aide told investigators that she ensured that the cabin was "secure," implying that passengers were restrained, and that other items were secured before the takeoff roll. Physical evidence and passenger statements indicated that this was not the case. The Safety Board concluded that the cabin aide did not perform a seatbelt compliance check before the accident flight, which resulted in two passengers being unrestrained during the accident sequence.

The cabin aide was not required to receive safety-related training because she was not a required crewmember (flight attendant) for the accident flight. Nonetheless, the operator did provide its cabin aides with some training. The accident cabin aide stated that she had received verbal instruction regarding the emergency main cabin door operation and had operated the main cabin door handle and electric toggle switch in a simulated emergency scenario during her training. Her description of her efforts to operate the door after the accident was consistent with the training she reported that she had received; however, it revealed that her training had not provided her with an adequate understanding of the door mechanism and operation. The cabin aide told investigators that she was not familiar with the arm/disarm handle and that she tried to use the electric switch at the top of the bulkhead to operate the door; however, this switch is not needed, and should not be used, during emergency operations.

The Safety Board was concerned that Part 135 operators and/or certificate holders may delegate important safety functions to cabin aides/customer service representatives who are not properly trained and qualified to perform those functions. Further, the Board was concerned that passengers might mistakenly believe that a cabin aide/customer service representative on a charter flight had received safety training equivalent to that of a qualified flight attendant, when in fact, that aide/representative might have received minimal or no safety training. The Board believed that providing those individuals with basic safety training could provide valuable safety results in an emergency, especially in the event of flight crew injury such as was seen in this accident.

On the basis of the cabin aide's performance during the accident sequence, including the lack of a seatbelt compliance check,

her failure to collect beverage service items before takeoff, and her inability to open the main cabin door and conduct a competent evacuation, the Board concluded that the cabin aide's training did not adequately prepare her to perform the emergency duties with which she was tasked. The Board issued a recommendation to the FAA to require that any cabin personnel on board 14 CFR Part 135 flights who could be perceived by passengers as equivalent to a qualified flight attendant receive basic FAA-approved safety training in at least the following areas: preflight briefings and safety checks, emergency exit operation, and emergency equipment usage. The recommendation also stated that such training should be documented and recorded by the Part 135 certificate holder.

### **Aircraft rescue and firefighting**

Teterboro air traffic controllers indicated that the airplane's acceleration appeared to be normal; however, the airplane did not lift off when they expected it to. Therefore, the controllers initiated notification to ARFF before the airplane ran off the end of the runway. According to interviews with ARFF, ATC, and passengers, ARFF responded within 1 minute of notification, reached the airplane within 3 to 4 minutes of the accident, and immediately initiated efforts to extinguish the exterior airplane fires. Firefighting personnel from neighboring communities arrived to assist in the firefighting effort. However, the interior fire was not extinguished until a high-reach extendable turret (HRET) vehicle with a skin-penetrating nozzle arrived from Newark International Airport. The vehicle arrived about 0851 (about an hour and 33 minutes after the accident), and the interior fire was extinguished within minutes of its arrival. Although the vehicle was successful in extinguishing the fire, the operators initially experienced problems piercing the airplane skin when the nozzle tip folded backwards and had to be reset.

The Safety Board has a long history of concern about the ability to extinguish aircraft interior fires. For example, the Board's 1998 report on its investigation of a DC-10 cargo aircraft fire at Newburgh, N.Y., concluded that ARFF "capabilities must also be improved so that firefighters are able to extinguish aircraft interior fires in a more timely and effective manner" and issued Safety Recommendation A-98-79 to the FAA. The recommendation asked the FAA to "review the aircraft cabin interior firefighting policies, tactics, and procedures currently in use, and take action to develop and implement improvements in firefighter training and equipment to enable firefighters to extinguish aircraft interior fires more rapidly." The Safety Board classified the recommendation as "Closed-Acceptable Action" because, as a result of FAA research and development, an elevated boom with a skin-penetrating nozzle was developed, and the FAA funded 12 regional ARFF training facilities with simulators that were to be used for interior attack training.

On Feb. 7, 2006, another inflight fire occurred on a cargo flight shortly before it landed at its destination airport in Philadelphia, Pa. The three flightcrew members sustained minor injuries and the airplane and most of its cargo were destroyed by fire after landing. The ARFF personnel who used the HRET/SPN during the emergency response stated that they experienced problems penetrating the fuselage with the device and had to reposition the tip of the nozzle a few times before successfully piercing the airplane's fuselage.

In 2005, the FAA conducted research that determined that the HRET/SPN outperformed the standard roof-mounted turret and handline, including the ability to better control and contain the spread of interior fires and reduce high cabin temperatures. FAA and International Fire Service Training Association (IFSTA) training materials state that the successful use of the device depended on the skill level of the operator and required continual training in operations, tactics, and strategies. Although the FAA's Advisory Circulars (AC) 150/5210-17A and 150/5220-10C state that ARFF personnel should be trained to identify the proper procedures for the use of each hose, nozzle, and adapter used locally, and should be provided guidance on the equipment training, neither of the ACs specifically addressed training on the use of the HRET/SPN.

Despite having received some training on the HRET/SPN, ARFF personnel at both Philadelphia and Teterboro encountered problems using the device. Further, because of aviation's excellent safety record, most ARFF personnel may not have any actual experience fighting an interior fire. The PHL and TEB ARFF

personnel who used the HRET/SPN during the emergency responses had never used the device during an actual emergency response up to that time.

The Safety Board concluded that some ARFF personnel were not adequately trained on the use of the HRET/SPN, which reduced the effectiveness of the device in fighting interior aircraft fires. The Safety Board recommended that the FAA "provide guidance to aircraft rescue and firefighting personnel on the best training methods to obtain and maintain proficiency with the high-reach extendable turret with skin-penetrating nozzle." (A-07-100)

Examination of the Teterboro accident provides important lessons for the investigator; although most investigative agencies expend a great deal of resources explaining the cause of accident fatalities, it is important that non-fatal accidents also receive an appropriate level of investigation. As was seen in this case, comprehensive information gained from passengers, crew, and firefighters provided substantial support for agency safety recommendations, which are intended to improve safety throughout the industry. ♦

# Problems in Operating Emergency Evacuation Slides: Analysis of Accidents and Incidents With Passenger Aircraft

By Gerard van Es, Senior Consultant, NLR-Air Transport Safety Institute, Amsterdam, the Netherlands  
(Presented by Rombout Weaver)



*Gerard van Es is a senior consultant in safety and flight operations at the NLR Air Transport Safety Institute, the Netherlands. For 12 years, he has been involved in accident and incident investigation and analysis. He has conducted numerous studies into runway incursions, landing overruns, flight data analysis, pilot-controller communication, occupant-survivability, and more. He holds a bachelor of science degree in aircraft engineering and a master of science degree in aerospace engineering.*

## Abstract

One concern in cabin safety is that aircraft can be evacuated quickly and safely in case of an emergency. Aircraft that have emergency exits more than 6 feet from the ground are required to have an approved means to assist the occupants in descending to the ground. For this purpose, emergency evacuation slides are used. The rapid deployment, inflation, and stability of evacuation slides are critical elements of the evacuation system. Any problem with one of these elements could endanger the lives of the occupants. Unfortunately, investigations of accidents and serious incidents involving an evacuation of the occupants often showed that slides did not function properly. This paper presents an analysis of historical emergency evacuations in which slides were used. The factors that have hampered the use of emergency evacuation slides are identified from these data and are analysed in-depth.

Examination of historical emergency evacuations involving evacuation slides showed that in 54% of all cases one or more slides did not function properly. The most important slide problems identified in evacuation accidents are slide inflation problems, aircraft attitude, wind, burned slide, incorrect rigging of the slide, and ripped slide. Problems with evacuation slides have been reported since their first appearance on aircraft. Despite many recommendations made by accident investigation boards regarding the improvement in slide reliability, problems with slides keep occurring at a similar rate.

## Introduction

On Aug. 2, 2005, an Air France Airbus A340-300 aircraft departed Paris, France, on a scheduled flight to Toronto, Canada, with 297 passengers and 12 crewmembers on board. While approaching Toronto, the flightcrew members were advised of weather-related delays. On final approach, they were advised that the crew of an aircraft landing ahead of them had reported poor braking action,

and the Air France aircraft's weather radar was displaying heavy precipitation encroaching on the runway from the northwest. The aircraft landed long down the runway and reverse thrust was selected late after touchdown. The aircraft was not able to stop on the 9,000-foot runway and departed the far end. The aircraft stopped in a ravine and caught fire. The cabin crew ordered an evacuation within seconds of the aircraft stopping because fire was observed out the left side of the aircraft, and smoke was entering the cabin. All passengers and crewmembers were able to evacuate the aircraft before the fire reached the escape routes. A total of 2 crewmembers and 10 passengers were seriously injured during the crash and the ensuing evacuation. The Air France Airbus A340-300 was equipped with emergency evacuations slides as required by certification rules. At one exit (L2) the evacuation slide did not deploy and the passengers had to jump out (see Figure 1). Of the 16 passengers using this exit, 2 were seriously injured: one when he jumped from the exit (10-12 feet above the ground), and the other when pushed out of the exit by another passenger. The slide at another exit (R3) deployed correctly. However shortly afterwards this slide deflated and the Exit R3 was assessed as unusable by the cabin crew. The slide at Exit L1 partially deployed/inflated. Given the nose-down, left-wing-high attitude of the aircraft, neither the intermediate tie restraint device nor the toe tie restraint device separated from the slide. As a result, the slide came to rest folded in half against the fuselage. When passengers jumped from Exit



*Figure 1. Evacuation of passengers at Exit L2 without an emergency evacuation slide.*



L1, some became trapped in the folded portion of the slide and were unable to extricate themselves before other passengers jumped on top of them. During the evacuation, the slide deflated completely. Post-occurrence examination of the slide revealed that it had been punctured in two areas. The slide at emergency Exit R1 deployed automatically as designed. However, the angle of the slide was very shallow because it was almost perpendicular to the aircraft. As a result, the rate of descent was slowed considerably. At the bottom of the slide, vegetation on either side of the deployment path pushed against the slide, causing it to curl inward, forming a tube. At one point, the R1 cabin attendant had to stop the evacuation to wait for passengers already on the slide to pass through this tube. The problems with several of the slides on the Air France A340 hampered the evacuation and also caused serious injuries to the passengers. In the end the evacuation was successful due to the training and actions of the whole cabin crew. (Source: TSB report A05H0002).

### Study objective and scope

The main objective of the study is to make an inventory of common problems when using emergency evacuation slides. The study is limited to western-built passenger aircraft equipped with evacuation slides.

### Analysis of evacuation occurrences

#### Approach

In order to make an inventory of common problems when using emergency evacuation slides, data of historical evacuation occurrences are analyzed. For the purpose of this study, an evacuation is defined as the disembarkation of passengers because of an existing or perceived emergency. The term evacuation is used in a generic sense and includes precautionary evacuations and emergency egress situations<sup>1</sup>.

First some of the available studies on aircraft emergency evacuations are analyzed. Secondly evacuation occurrences involving passenger aircraft are identified using several data sources. The first data source to be used is the NLR Air Safety Database. This database covers accidents and (major) incidents with civil aircraft worldwide. The accidents in the NLR Air Safety Database are often related to occurrences involving (significant) damage to the aircraft and/or injuries to the passengers<sup>2</sup>. Since such occurrences are rare, it was also necessary for this study to analyze evacuations with less serious consequences. These are often precautionary evacuations. For this purpose, data from the following mandatory occurrence reporting systems are used: the Canadian Civil Aviation Occurrence Reporting System (CADORS), UK's Mandatory Occurrence Reporting Scheme (MORS,) and from the United States the FAA Accident Incident Data System (AIDS). Additional data for U.S. operators were obtained from other sources<sup>3</sup>.

All the data from the previous-mentioned sources include occurrences with aircraft that are equipped with evacuation slides as well as aircraft that do not have evacuation slides. The evacuations with this last category of aircraft are excluded from this study in light of its objectives.

The results of the analysis are discussed in the next sections.

### Results

#### Literature survey

A literature survey of previous investigations on problems with

evacuation slides was conducted. A number of relevant studies were found of which the most interesting results (in light of the present study) are briefly discussed in this section.

In a review of techniques used in crash protection and emergency egress from transport aircraft, deficiencies with emergency escape equipment were summarized by Snyder (Snyder, 1976). The deficiencies quoted by Snyder are inflation problems, problems due to wind, burned slides, punctured slides, and aircraft attitude. These problems are based on NTSB reports concerning accidents that occurred during the early 70s.

The CAA UK studied the reliability of slides by analyzing slide occurrences from 1980 to 1994 with UK-registered aircraft (CAA UK, 1995). The study looked both at problems that occurred with slides during maintenance/test deployment, and the use of slides during actual evacuations. Some of the problems identified during maintenance/test deployment are: incorrect assembly of the slides (29%), grit-bar mechanism failure (15%), mis-rigging (11%), inflation device malfunctions (7%), and failure to deploy with no obvious cause (6%)<sup>4</sup>. In the period studied by the CAA UK, 62 actual emergency evacuations (with slides involved) occurred with UK-registered aircraft. In nine cases (15%), slide problems were identified. No fatalities were recorded with these evacuations indicating that these were minor events only (incidents). The study conducted by the CAA UK does not report any reasons for the slide problems.

Detailed studies on emergency evacuations were conducted by the accident investigation organizations from the U.S. (NTSB) and Canada (TSB). These organizations reviewed past emergency evacuation accidents with U.S.- and Canadian-registered, passenger-carrying aircraft covering different periods in time (NTSB, 1974; NTSB, 2000; TSB, 1995; and Fedok, 2001). The TSB study (TSB, 1995) showed that in 47% of the evacuations where slides were used, some problem occurred with the slides. One NTSB study (NTSB, 2000) found that in 37% of the evacuations involving slide use, the slides did not operate correctly. In the other NTSB study (NTSB, 1974), an almost similar percentage was found (40%). This leads to a combined slide problem rate of 41% (combination of the results of the three studies). The problems with evacuation slides identified in the TSB/NTSB studies are listed in Table 1. Failure of the slide to inflate was identified in 46.9% of the cases and is by far the biggest problem found by the NTSB and the TSB.

**Table 1. Problems with Slides Identified by NTSB and TSB**

Identified problem	Amount (%)*
No (automatic) inflation of slide	46.9
Problems due to wind	12.5
Problems with slides due to extreme attitude of the aircraft	12.5
No deployment of slide due to problems with emergency exit door	9.4
Slide broke loose of aircraft	9.4
Slide inflated inside aircraft	6.3
People injured because they loose stabilisation on descent	3.1

\*One accident can have more than one slide problem assigned

### Analysis of accidents involving evacuations

Searches were conducted in the NLR Air Safety Database for survivable, Western-built<sup>5</sup>, passenger jet aircraft accidents involving evacuations in which emergency evacuation slides were used. The query was conducted for the period 1970-2003 and covered aircraft operations worldwide. The query resulted in 151 accidents

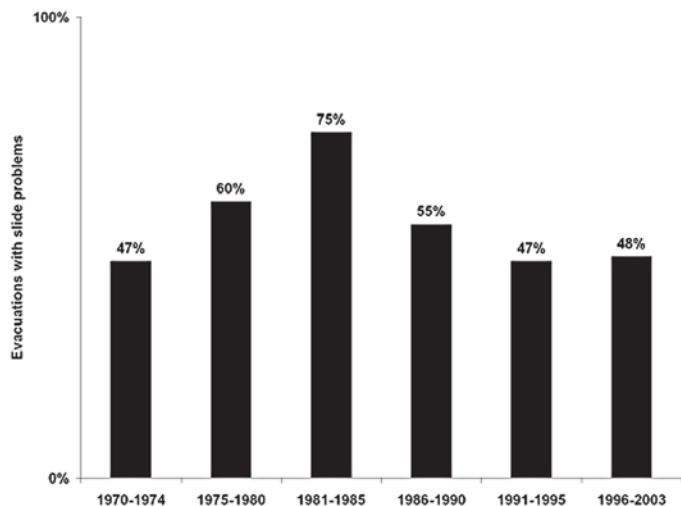

Figure 2. Relative number of evacuations with slide problems during the period 1970-2003.

in which emergency evacuation slides were used. Problems with using the slides were identified in 81 (54%) accidents. As shown in Figure 1, this share increased starting from the late 70s until the earlier 80s. The share has dropped during the late 80s. Since then it has not changed much (see Figure 1). An overview of the identified problems with evacuation slides in 81 analyzed accidents is shown in Table 2. The ICAO ADREP taxonomy was used for the classification of the slide problems. Eight-nine slide problems were identified in the sample of 81 accidents.

In 25 (28.1%) cases, the slide did not inflate (not automatically nor manually). The cases in which the slide did not inflate automatically—but did directly after the manual inflation handle was pulled—were not considered as slide problems in this study. However, when there was a significant delay in deploying the slides manually, the case would be considered in the present analysis. The NTSB/TSB results shown in Table 2 show a higher amount of problems with the inflation of slides. This is due to the fact those cases where the slide would not automatically deploy, but did manually, were still counted as a slide problem by the NTSB/TSB. There does not appear to be a general explanation why some slides did not inflate properly. There are a large number of different causes such as empty inflation bottles and incorrect assembly.

Table 2. Problems Identified with the Use of Slides In 81 Accidents Analyzed

Identified problem	Amount (%)*
Slide not inflated	28.1%
Aircraft attitude	15.7%
Other	13.5%
Wind	12.4%
Slide burned	11.2%
Incorrect rigging	7.9%
Slide ripped	6.7%
Unknown	4.5%

\*One accident can have more than one slide problem assigned

In 14 (15.7%) cases, the aircraft attitude at rest was such that some of the slides were either too steep, did not reach the ground, or curled up under the aircraft (due to limited space to deploy it properly). Unusual aircraft attitudes were mainly the result of the collapse of the nose gear or the main aircraft landing gear. However, in some cases the aircraft ended in a ditch or over an em-

bankment. Steep slide angles appear to be the biggest problem for evacuees. At a slide angle of approximately 48 degrees, evacuees have a tendency to hesitate before entering the slide because of its steep appearance (Barthelmess, 1980). Such steep angles were reported in a number of cases.

Wind had an adverse effect on the use of escape slides in 11 (12.4%) cases. In these cases, the wind blew them up against the sides of the aircraft preventing their use.

Table 3 lists the 11 cases. The mean wind during these evacuations varied from 6 to 28 knots. A similar range of wind values (3-25 knots) was found for those evacuations in the sample in which wind did not cause a problem when using the slides. An explanation for this last observation in the data could be that the wind direction relative to the aircraft's position also plays an important role.

The slides were burned in 10 (11.2%) cases. In all these cases, slides were deployed at the side of the aircraft where a fire was present. Due to the intensity of most of the fires, the burning of the slide was unavoidable.

Incorrect rigging of the slide was identified as the cause of the slide problem in seven cases (7.9%).

In six cases (6.7%), the slide was ripped. In four cases, it was determined that this was caused by the shoes some of the evacuees were wearing.

There are a variety of problems with slides that were listed under the category "other" in Table 2. Some examples are slides falling of the aircraft after being deployed and slides that inflated into the aircraft itself.

Table 3. Cases with Slide Problems due to Wind as Identified in the Accident Sample

Date	Location	Aircraft type	Wind speed (knots)
7-30-1971	San Francisco, USA	B-747-100	20
1-02-1982	Sault Ste. Marie, Canada	B-737-200	22 gusting to 36
5-12-1983	Regina, Sask, Canada	DC-9-32	18 gusting to 28
11-05-1983	Johannesburg, South Africa	B-747-B	6
3-25-1987	Chicago, USA	DC-10-10	14
2-01-1990	Baltimore, USA	DC-10-10	12
3-05-1994	Regina, Canada	DC-9-32	22 gusting to 27
12-24-1997	Schiphol, the Netherlands	B-757-200	32 gusting to 42
7-09-1998	San Juan, Puerto Rico	A300-600	13
7-12-2000	Wien, Austria	A310	13 gusting to 17
11-30-2000	Shannon, Ireland	B-737-800	28 gusting to 42

### Analysis of incidents involving evacuations

The accidents analyzed in the previous section are often related to occurrences involving (significant) damage to the aircraft and/or injuries to the passengers. To have an understanding of slide problems that have occurred during less serious events, incidents involving slide use were analyzed (including precautionary evacuations). These incidents are also used to estimate the slide use frequency of occurrence. This frequency can be used to determine the probability of emergency evacuation slide use in mean wind conditions higher than 25 knots. Evacuation data from the following mandatory occurrence reporting systems are used: the Canadian Civil Aviation Occurrence Reporting System (CADORS), UK's Mandatory Occurrence Reporting Scheme (MORS), and from the United States the FAA Accident Incident Data System (AIDS). The U.S. data were expanded with additional evacuation occurrences obtained from other sources including an airport survey. The overall time period ranged from 1987-2003. However, each of the three sources had slightly dif-

ferent time periods. The Canadian data covered the period 1995-2003, the UK data 1987-2003, and the U.S. data 1988-1996. Narratives were available for all the reported evacuations with Canadian- and UK-registered aircraft in the time periods considered. However, this was not the case for all of the U.S. data.

For the period of 1995 through 2003, 12 slide involving evacuations with Canadian-registered aircraft were identified. There were no reported slide problems with these 12 evacuations.

For the period of 1987 through 2003, 63 slide involving evacuations with UK-registered aircraft were identified. In three cases (4.7%), problems with the slides were reported. There was a case in which the slide twisted on inflation. There was a case in which the slide was punctured (possibly by high-heeled shoes). In last case, the slide deployed partially into the galley.

Hynes (Hynes, 1999) evaluated precautionary emergency evacuations with U.S.-registered aircraft that occurred during the period of 1988 through 1996. The primary data sources used for the evaluation included the FAA, the NTSB, and NASA, as well as the records of airport managers (through a survey sent to 63 airports). Additional data were obtained from airlines, insurance adjusting firms, and litigation records. The data final data sample contained a total of 130 emergency evacuations involving the deployment of slides<sup>6</sup>. For 80 of the 130 evacuations, narratives were available. Analysis of the 80 evacuations revealed that in seven cases (8.8%) the slides did function as expected. In three cases, the slides would not inflate; in one case the slide fell off the aircraft. The reasons for slide problems in the remaining three cases were not reported.

### Discussion of results

The problems with evacuation slides as identified in this study are similar to those identified in previous studies. The data analyzed in this study suggest that the basic problems with evacuation slides in accidents have been not resolved over the last 33 years. Safety organizations such as the National Transport Safety Board (NTSB) of the U.S. have addressed the problem of proper functioning of evacuation slides in the past. The importance of having proper functioning slides follows from the examination of the fatality rate of the analyzed evacuation accidents in this study. The fatality rate<sup>7</sup> in those evacuations were problems with the slides occurred is 1.7 times higher than for those evacuations were no problems were encountered with the slides. Clearly properly functioning evacuation slides can reduce the number of fatalities during survivable accidents.

The share of problems (54%) with slides found in the analyzed accidents is much higher than found in the incidents (6.5%, combined result). There are several reasons for this difference. Accidents often are related to damaged aircraft, fires, and collapsed nose and main gears resulting in rather unique problems with evacuation slides. By definition, such problems will not be found with incidents. However, it was expected that inflation problems would have occurred at a similar rate for both accidents and incidents (in the order of 28%). It is believed that the incident reports examined in this study do not always mention problems with evacuation slides when they occurred. The level of detail of the information provided in the incident reports is normally far less than the information that is given in accident reports. Detailed information regarding evacuation means is often not provided in incident reports; therefore, the number of problems with

evacuation slides identified in incidents in the present study could be underreported.

The most significant problem with slides identified in this study is that the slides would not inflate. An analysis of service difficulty reports (SDRs) filled by U.S. operators also showed that the vast majority of SDRs related to slides (28%) would have resulted from slide inflation problems<sup>8</sup>. Improper packing/installation and improper maintenance cause many of these problems.

Problems with slides due to wind have been identified in several cases. The problems occurred under both moderate as well as severe mean wind conditions, which indicates that the mean wind speed itself is not a decisive factor. This is further shown by the fact that numerous evacuations with slides occurred without any problems due to wind, despite the fact that the wind conditions were very similar to those when problems did occur due to the wind. Most likely the wind direction plays an important role. With an unfavorable wind direction even moderate wind conditions can cause problems when using slides. Another factor could be the gustiness of the wind. When having moderate wind conditions, strong gusts can cause difficulties when operating the slide. The influence of strong gusts upon the proper functioning of slides has not been examined to the knowledge of the present authors. The current JAR/FAR 25, Section 25.810 Emergency Egress Assist Means and Escape Route, states that "*An approved means to assist the occupants in descending to the ground, must have the capability, in 25-knot winds directed from the most critical angle, to deploy and, with the assistance of only one person, to remain usable after full deployment to evacuate occupants safely to the ground.*" This rule became effective as of Aug. 20, 1990. The rule originates from a proposal made in the 80s (see published Notice of Proposed Rule Making NPRM No. 84-21). Except for the B-737-800, all aircraft listed in Table 3 were certified before 1990. This means that the involved aircraft were certified for manufacture prior to the introduction of the requirement JAR/FAR 25, Section 25.810 regarding the maximum wind speed under which slides must function and are therefore exempted from this requirement. The B-737-800 listed in Table 3 was certified in 1998. During this accident, the mean wind was 28 knots, which is slightly higher than the maximum wind under which the slides should be able to function without problems due to the wind.

### Conclusions

- Examination of historical accidents involving evacuation slides showed that in 54% of all cases one or more slides did not function properly.
- Examination of historical incidents involving evacuation slides showed that in 6.5% of all cases one or more slides did not function properly.
- The most important slide problems identified in evacuation accidents are slide inflation problems, aircraft attitude, wind, burned slide, incorrect rigging of the slide, and ripped slide.
- Problems with evacuation slides have been reported since their first appearance on aircraft. Despite many recommendations made by accident investigation boards regarding the improvement in slide reliability, problems with slides keep occurring at a similar rate.

### Recommendations

- Disseminate the findings of this report to all interested parties (including civil aviation authorities, transport safety boards, air-



craft manufacturers, slide manufacturers, and airlines).

- Analyze the influence of strong gusts upon the proper functioning of slides.
- Analyze service difficulty reports related to slides to identify the relation with problems found during accidents and incident evacuations and to monitor any influence of regulations regarding slide reliability. ♦

## References

- Barthelme, S.J., Evacuation Slides...History and New Technology, Flight Safety Foundation FSF, Cabin Crew safety Bulletin, NOV/DEC, 1980.
- Carbaugh, Hard Nose Gear Touchdown, Flight Safety Foundation FSF, European Aviation Safety Seminar, 2002.
- CAA UK., Escape Slides. Data + Plus, published by Safety Regulation Group SRG, CAA UK, 1995.
- Fedok, J.T., Evacuation Slide and Slide/Raft Reliability, National Transport Safety Board (NTSB), International Aircraft Fire and Cabin Safety Research Conference, 2001.
- Hynes, M.K., Frequency and Costs of Transport Airplane Precautionary Emergency Evacuations. FAA Report DOT/FAAJAM-99/30, 1999.
- NTSB, Emergency Evacuation of Commercial Airplanes, National Transport Safety Board, Safety study NTSB/SS-00/01, 2000.
- NTSB, Safety Aspects of Emergency Evacuations from Air Carrier Aircraft, National Transport Safety Board, Special study NTSB-AAS-74-3, 1974.
- Snyder, R.G., Advanced Techniques in Crash Impact Protection and

Emergency Egress from Air Transport Aircraft, AGARD AG-221, 1976.

TSB, A Safety Study of Evacuations of Large Passenger-Carrying Aircraft, Transport Safety Board Canada, Report SA9501, 1995.

## Acknowledgement

The authors gratefully acknowledge the cooperation and assistance given by Joji Waites of the CAA UK SRU, Jennifer McCarthy of Transport Canada, System Safety, and Günther Raicher of the Flugunfalluntersuchungsstelle of Austria.

## Endnotes

- 1 Definition taken from the Transportation Safety Board of Canada.
- 2 The accident definition given by ICAO ANNEX 13 is used in this study.
- 3 In particular, data were obtained from a survey made by Hynes and Associates for the FAA in 1999.
- 4 The percentages refer to the total number of problems found during maintenance/test deployment.
- 5 The NLR Air Safety Database does contain information on both Western- and Eastern-built aircraft accidents. However, information regarding evacuations and slide use is very limited for Eastern-built aircraft.
- 6 These evacuations were limited to only those aircraft that operated under Part 121.
- 7 Ratio of total number of onboard fatalities by the total occupants on board.
- 8 Data were obtained from the FAA. Reporting period for the SDRs was from 1997-2003.

# ISASI 2008 Pictorial Review

Photos by Esperison Martinez, Editor

